



# AND

Discover Precision

Online Catalogue

Contact Your Local Western Australian Representative Today!



**Scientific  
Partners  
Australia**  
Your partner in science

Scientific Partners Australia  
Mob: 0447 733 832  
Fax: 08 9456 0363  
E: [sales@scientificpartners.com.au](mailto:sales@scientificpartners.com.au)

# 2022/23

Weighing & Inspection

Prices are effective from April 2022

# Table of Contents

## LABORATORY & ANALYTICAL BALANCES

HR-AZ / GR Series	4
GH / GX-AE Series	5
BM Series	6
BA-T Series	7
FX-i / FX-iWP Series	8
FZ-i / FZ-iWP Series	9
GX-A / GF-A Series	10
GX-K / GF-K Series	11
GP Series	12

## COMPACT BALANCES

HT-120 / HT Series	13
HT-CL Series	14
EJ Series	15
EW-i Series	16
EK-i Series	17
EK-L Series	18
SJ-HS Series	19
SJ-WP MK2 / SJ-WP BT Series	20
SK-WP / HL-WP Series	21

## INTRINSICALLY SAFE SCALES

EK-EP / HV-CEP Series	23
-----------------------	----

## INDUSTRIAL, HEAVY DUTY & WAREHOUSE SCALES

EM Series	24
FG Series	25
HVW-C / HVW-CP Series	26
HV-CWP Series	27
SE Series	28
SC Series	29
SW Series	30
FS-Ki Series	31
SA Series / Baseworks	32
AD-300 / AD-600 Series / SD-200	33
ELP-700 / ELP-1200 Pallet Scale	34
A&D 3000 Pallet Scale	35
ELP-3000 Pallet Scale	36
OHT Scale	37

# Table of Contents

## INDICATORS

38	AD4401A / AD4402 / AD4404
39	AD4405 / AD4406A / AD4407
40	AD4408 / AD4410 / AD4329
41	AD4430A / AD4430B / AD4430R
42	AD4530 / AD4531B
43	AD4413-CW / AD4532B / AD4541-V/I
44	FSi-D / SW-D / SC-D

## COUNTING & RETAIL BENCH SCALES

45	HC-i Series
46	FC-i / FC-Si Series

## X-RAYS, CHECKWEIGHERS & METAL DETECTORS

48	Custom Checkweighers / Carton Rollers
49	ProteX X-Ray
50	Intelligent Checkweigher 600g / 2kg / AD-4413-CW
51	Intelligent Checkweigher 6kg
52	Metal Detectors AD-4971
53	Metal Detectors AD-4976

## LABEL PRINTERS & SOFTWARE

54	Thermal Printers & WinCT Software Guide
----	---

## PERIPHERALS & BLUETOOTH CONNECTIVITY

55	AD1683 / AD-720Di / Remote Displays / AD8922A
56	AD1688 / AD8527 / AD1687 / AD1691
57	BT Adapters / BT Converters / AD8931 / RS232 USB
58	BT Connectivity Product Guide

## TESTING & ANALYTICAL INSTRUMENTS

59	Moisture Analysers
60	Viscometers
61	RV Rheometer
62	Pipette Testers / Density Kits
63	MC Series
64	AD-4212A / AD-4212B System
66	AD-4212C / AD-4212L / AD-4212D System

## HEALTH, PROFESSIONAL & PERSONAL SCALES

68	Professional / Personal Scales
----	--------------------------------



# HR-AZ & GR Series

## Compact Analytical Balances



HR-AZ model

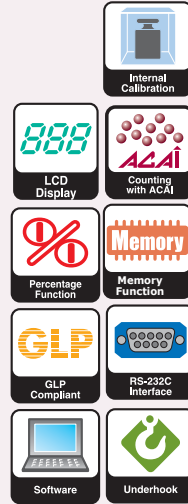

GR Series

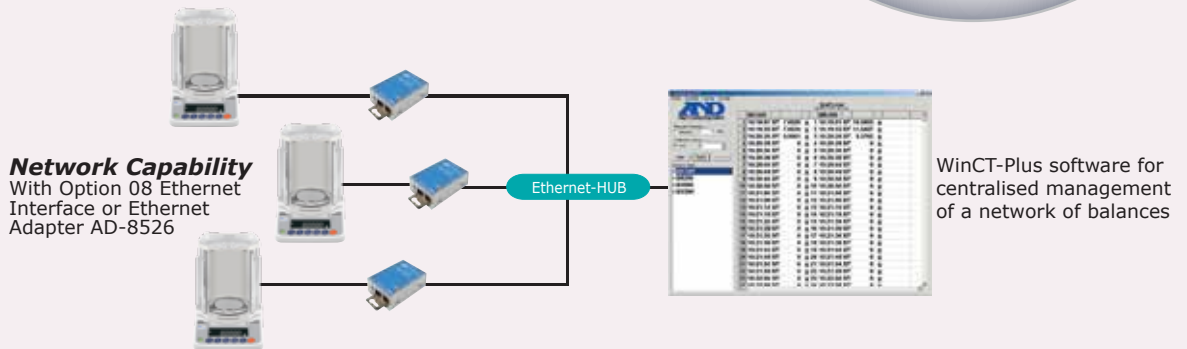

### Options



### ● HR-AZ Features

- Easy data capture with free software
- Strong protection against dust & water
- Shock absorber function
- Auto Power ON/OFF function
- B5 size footprint for use in narrow space
- SCF - Statistical calculation function
- Easily removable large breeze break
- Fast response time of 2 seconds
- LAN - Ethernet interface optional

### ● GR Features

- Easy data capture with free software
- One-Touch automatic calibration with just one push of a button
- GLP, GMP and ISO compliant
- Automatic calibration when ambient temp changes detected
- Standard RS232C interface for PCs, printers or other peripherals
- ID number for GLP output
- Auto Power Off function

Specifications	HR-250AZ	GR-200	GR-202	GR-300
Price (ex GST)	\$2,280	\$3,860	\$6,490	\$6,030
Part Number	06032800	06034100	06034200	06034300
Calibration	Internal & External	Internal & External	Internal & External	Internal & External
Capacity	252g	210g	210g / 42g	310g
Resolution	0.1mg	0.1mg	0.1mg / 0.01mg	0.1mg
Dimensions	198(W)x294(D)x315(H)	249(W) x 330(D) x 328(H)		
Pan Size	Ø 90mm	Ø 85mm		
Power Supply	AC Adaptor TB-S139 included			

Accessories	Part Number	Price (ex GST)
Serial Cable HR-AZ DB9 Female to DB9 Female	03000007	\$60
Serial Cable GR series D25 Male to DB9 Female	03000001	\$60
HR-A OP-02 USB Interface with Cable	06054001	\$210
HR-A OP-08 Ethernet Interface & WinCT Plus	06054002	\$1,030
HR-A OP-09 Built in Rechargeable Battery**	06054003	\$680
AD-1654 Density Determination Kit	06036350	\$1,190

\*\* OP-09 cannot be used simultaneously with OP-02 & OP-08



# GH & GX-AE Series

## Analytical Semi-Micro Balances



GH-252



GX-224AE  
with ioniser built-in

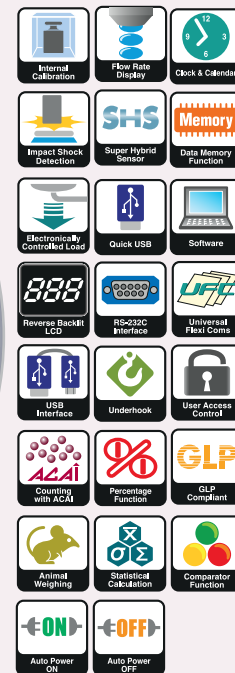

### ● GH-252 Features

- Easy data capture with free software
- One-Touch automatic calibration with one push of a button
- Antistatic glass
- GLP, GMP and ISO compliant
- Automatic calibration when ambient temp changes detected
- Standard RS232C
- WinCT Communications software
- Data memory function
- ID number for GLP output
- Auto Power Off function



Remote switch option for GR/GH. This switch can also be used on other balances. Please enquire.

### ● GX-224AE

- Easy data capture with free software
- Impact shock detection (ISD)
- Flow rate display (FRD) records flow rates easier
- Protection against vertical and transverse static overloading
- Fast stabilization of approx. 1 second
- One touch calibration using internal weight
- Automatic CAL when ambient temperature changes detected
- Timed calibration function
- Clearly visible, reverse backlit LCD display
- Auto Power Off function

Specifications	GH-252	GX-224AE
Price (ex GST)	\$7,230	\$6,050
Part Number	06034900	06034400
Calibration	Internal & External	Internal & External
Capacity	250g / 101g	220g
Resolution	0.1mg / 0.01mg	0.1mg
Dimensions	217(W) x 442(D) x 316(H)	259(W) x 358(D) x 332(H)
Pan Size	Ø 90mm	
Power Supply	AC Adaptor TB-S139 included	

Accessories	Part Number	Price (ex GST)
Serial Cable DB9 Female to DB9 Female	03000007	\$60
GH OP-02 Quick USB interface (GH)	06034001	\$220
GH OP-08 Ethernet interface (GH)	06034002	\$1,080
AD-1653 Density Determination Kit	06036300	\$1,210
AD-1682 Rechargeable Power Supply (external)	06087210	\$800
OP-03 RS232C Host interface (GX-AE)	06053001	\$220
OP-09 Built in rechargeable battery (GX-AE)	06053002	\$690
OP-12 Animal Weigh Pan (GX-AE)	06053005	\$410
Remote switch option	LB	\$240



# BM Series

## Micro\*, Semi-Micro & Premium Analytical Balances

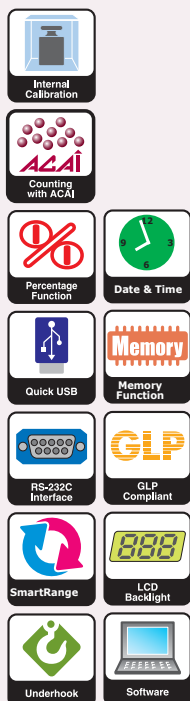

### Options



Neutralizing chamber  
Separator plate (removable)  
Weighing Chamber



BM-5 shown with AD-1676 breeze break

To block drafts, A&D have adopted a double-ring structure around the weighing pan and two vertical shields under the separation plate. This offers more space and easier operation. The removable separator plate enables the user to have one large chamber if needed.

**\*Microgram BM models are only available via qualified & trained A&D BM Micro Partners**

In built fanless ionizer



● **New BM-5 Model** includes AD-1676 breeze break as standard

- Simple data capture with free WINCT software
- Large weighing chamber for improved usability
- Built-in temperature, humidity, and atmospheric pressure sensors
- Interlockable slide doors allowing efficient operation with both hands
- Sensitivity drift (10 °C to 30 °C, when self calibration is not used) ±2 ppm / °C
- Easy, fanless elimination of static electricity using a built-in ionizer & antistatic breeze break
- Calibration: Automatically triggered based on temperature variation or by operator
- Can store up to 200 sets of weighing data (100 sets with date & time)
- AD-1688 as standard accessory: dedicated USB key to record weighing data as well as environmental parameters into MS Excel readable files
- 12 weighing units : g, mg, oz, ozt, ct, mom, dwt, GN, tael, tola, pcs (counting), %.
- Optional pipette accuracy testing kit
- Output interfaces: RS-232C (standard), Quick USB (standard), Ethernet (optional)

**OPTIONS: Recommended to optimise your BM measurement performance.**

Specifications	BM-5	BM-22	BM-200	BM-500
Price (ex GST)	\$17,750	\$19,470	\$9,690	\$10,810
Part Number	06035900	06035400	06035500	06035700
Calibration	Internal & External	Internal & External	Internal & External	Internal & External
Capacity	5.2g	5.1g / 22g	220g	520g
Resolution	0.001mg	0.001mg / 0.01mg	0.1mg	0.1mg
Dimensions	259 (W) x 466 (D) x 326 (H) mm			259(W) x 466(D) x 326(H) mm
Pan Size	Ø 25mm (50 and 95mm for filter pans)		Ø 90mm	
Power Supply	AC Adaptor TB-S139 included			

● ex Japan

Accessories	Part Number	Price (ex GST)
Serial Cable DB9 Female to DB9 Female	03000007	\$60
OP-08 Ethernet interface with WinCT-Plus software	06035002	\$1,330
OP-14 Pipette accuracy testing kit	06035001	\$3,080
AD-1671 Anti-vibration platform	06035200	\$2,290
AD-1672 Table-top breeze break	06035100	\$2,400
AD-1672A Table-top breeze break (with inclined front beam panel)	06035800	\$2,720
AD-1676 Breeze Break (supplied standard with BM-5)	06035910	\$1,890
AD-1653 Density determination kit	06036300	\$1,210

# BA-T Series

## Micro Premium Balances



Sophisticated weighing at a touch.



- Automatic opening/closing of the breeze break doors using non-contact IR sensors
- 5-inch wide color touch screen that enables intuitive operation
- External ionizer for instant static removal
- Detachable breeze break unit and easily separable glass panes for better cleanability
- No grooves for the sliding doors so that contaminants do not accumulate
- Inner breeze break for 0.001 mg models to increase stability
- On-screen leveling assist
- Impact shock detection (ISD) providing feedback to prevent damage to the weight sensor (patented)
- AD-Just – Automatic self sensitivity adjustment using the internal weight
- Internal repeatability test to quickly assess the performance under a given environment
- Daily/periodic balance check support
- Smart routine check (SRC) function
- Minimum weight setting and alert functions
- User access control (UAC) with user rights management and password lock functions
- History information for log-in/log-out, operation, sensitivity adjustment, and impact shock detection (ISD)
- Selectable response characteristics for trading faster weighing speed for higher display stability or vice versa
- GLP/GMP/GCP/ISO compliant output to meet documentation requirements
- Gross/Net/Tare output
- Formulation mode for quick, accurate weighing of multiple samples to mix
- HPLC mode for preparing buffer solutions for high-performance liquid chromatography
- Counting mode with the Automatic Counting Accuracy Improvement (ACAI) function
- Percent mode function for target weighing or checking sample variation
- Statistical calculation function (SCF) to facilitate the analysis of measurements
- Underhook for weighing a magnetic material as well as measuring density

Specifications	BA-6TE
Price (ex GST)	\$POA
Part Number	06038000
Calibration	Internal & External
Capacity	6.2g
Resolution	0.001mg
Dimensions	173(W) x 305(D) x 204(H)
Pan Size	Ø 25mm
Power Supply	AC Adaptor TB-S139 included

ex Japan

Accessories	Part Number	Price (ex GST)
Serial Cable DB9 Female to DB9 Female	03000007	\$60
AD-1653 Density determination kit	06036300	\$1,145



# FX-i / FX-iWP Series

## Precision Balances



(FX-i-WP)



### Options



FX-300i-WP with standard breeze break

Large breeze break option

FX-3000i

**BEST VALUE**

**"There are TWO types of Lab staff... Those who HAVE SPILLED STUFF on their laboratory balance, and those that will!"**

● **Free data capture software**

- IP65 Water / Dust Proof (WP)
- Shock absorber function
- Auto Power ON/OFF function
- B5 size footprint for use in narrow space
- VFD Display for easy to read weighing results
- SCF - Statistical calculation function
- Standard RS-232C
- Fast compact SHS Sensor, response time only 1 second
- Quick USB or LAN interface (optional)
- Breeze breaks are only included with small capacity balances

Specifications	FX-300i●	FX-500i●	FX-3000i	FX-5000i	FX-300iWP●	FX-3000iWP
Price (ex GST)	\$1,170	\$1,350	\$1,460	\$1,520	\$2,010	\$2,010
Part Number	06054020	06054120	06054050	06054150	06055020	06055050
Calibration	External	External	External	External	External	External
Capacity	320g	520g	3200g	5200g	320g	3200g
Resolution	0.001g	0.001g	0.01g	0.01g	0.001g	0.01g
Dimensions	193(W) x 263(D) x 86(H) mm					
Pan Size	Ø 130mm		Ø 150mm		Ø 130mm	Ø 150mm
Power Supply	AC Adaptor TB-S139 (included)					

● These balances have breeze breaks included

Accessories	Part Number	Price (ex GST)
Serial Cable DB9 Female to DB9 Female (not waterproof)	03000007	\$60
Optional Square Pan fits 3000 models only 180mm x 180mm (approved by NMI)	06054009-E	\$210
FX-i OP-02 USB Interface with cable	06054001	\$210
FX-i OP-08 Ethernet Interface with WinCT Plus	06054002	\$1,030
FX-i OP-09 Built in Rechargeable Battery**	06054003	\$680
FX-i OP-10 Standard Small Breeze Break (Ext. dimensions 184(W) x 184(D) x 85(H) mm)	06054004	\$220
FX-i OP-11 Large Breeze Break (External dimensions 193(W) x 193(D) x 199.5(H) mm)	06054005	\$320
FX-i-WP Standard Small Breeze Break (Ext. dimensions 184(W) x 184(D) x 85(H) mm)	06054007	\$220
FX-i-WP Large Breeze Break (External dimensions 193(W) x 193(D) x 199.5(H) mm)	06054008	\$320
FX-i Plastic Protection Cover (box of 5)	AX-FXI-31	\$100
AD-1654 Density Determination Kit	06036350	\$1,190

\*\* OP-09 cannot be used simultaneously with OP-02 & OP-08



# FZi / FZiWP Series

## Precision Balances



Trade Approval  
NMI #6/4C/269

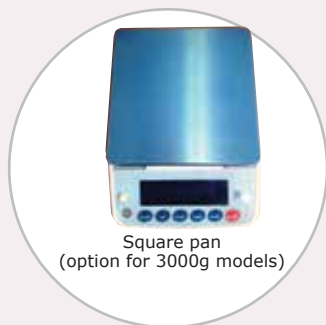

(FZ-i-WP)



### ● Free data capture software

- IP65 Water / Dust Proof (WP)
- Built-in internal calibration at the touch of a button
- All models come with the standard small breeze break
- B5 size footprint for use in narrow space
- VFD Display for easy to read weighing results
- SCF - Statistical calculation function
- Standard RS-232C
- Fast compact SHS Sensor, response time only 1 second
- Quick USB or LAN interface (optional)
- Custom teflon coating available, enquire with A&D

### Options



Specifications	FZ-300i	FZ-500i	FZ-3000i	FZ-5000i	FZ-300iWP	FZ-3000iWP
Price (ex GST)	\$1,410	\$1,580	\$1,820	\$1,940	\$2,360	\$2,360
Part Number	06056010	06056110	06056020	06056120	06056030	06056040
Price with NMI kit	\$1,530	N/A	\$1,940	N/A	\$2,470	\$2,470
Part Number	06056010-TA	N/A	06056020-TA	N/A	06056030-TA	06056040-TA
Calibration	Internal & External	Internal & External	Internal & External	Internal & External	Internal & External	Internal & External
Capacity	320g	520g	3200g	5200g	320g	3200g
Resolution	0.001g	0.001g	0.01g	0.01g	0.001g	0.01g
NMI Resolution	0.01g	N/A	0.1g	N/A	0.01g	0.1g
Dimensions	193(W) x 263(D) x 86(H) mm					
Pan Size	Ø 130mm		Ø 150mm		Ø 130mm	Ø 150mm
Power Supply	AC Adaptor TB-S139 (included)					

NMI Versions also require trade verification - fees apply

Accessories	Part Number	Price (ex GST)
Serial Cable DB9 Female to DB9 Female (not waterproof)	03000007	\$60
Optional Square Pan fits 3000 models only (approved by NMI) 180mm x 180mm	06054009-E	\$210
FZ-i OP-02 USB Interface with cable	06054001	\$210
FZ-i OP-08 Ethernet Interface with WinCT Plus	06054002	\$1,030
FZ-i OP-09 Built in Rechargeable Battery**	06054003	\$680
FZ-i OP-10 Standard Small Breeze Break (Ext. dimensions 184(W) x 184(D) x 85(H) mm)	06054004	\$220
FZ-i OP-11 Large Breeze Break (External dimensions 193(W) x 193(D) x 199.5(H) mm)	06054005	\$320
FZ-i-WP Standard Small Breeze Break (Ext. dimensions 184(W) x 184(D) x 85(H) mm)	06054007	\$220
FZ-i-WP Large Breeze Break (External dimensions 193(W) x 193(D) x 199.5(H) mm)	06054008	\$320
FZ-i Plastic protection cover (box of 5)	AX-FXI-31	\$100
AD-1654 Density Determination Kit	06036350	\$1,190

\*\* OP-09 cannot be used simultaneously with OP-02 & OP-08



# GX-A / GF-A Series

## Multi-Functional Precision Balances



Trade Approval  
NMI #6/4C/323  
(GX-A see notes below)

Internal Calibration GX-A	External Calibration GF-A	Clock & Calendar
Impact Shock Detection	Flow Rate Display	Data Memory Function
Electronically Controlled Load	Super Hybrid Sensor	Software
Reverse Backlit LCD	Quick USB	Universal Flexi Coms
USB Interface	RS-232C Interface	User Access Control
Counting with ACAA	Percentage Function	GLP Compliant
Animal Weighing	Statistical Calculation	Comparator Function
Auto Power ON	Auto Power OFF	Underhook
<b>Options</b>		
USB Host Interface	LAN-Ethernet Interface	Rechargeable Battery



GX-1003A  
(with Standard Breeze Break)



GF-4002A

● **Trade Approved GX-A series (except for GX-10001A, GX-1003A and GX-1603A)**

- Impact shock detection (ISD)\*1 allows users to take preventive measures as necessary
- Flow rate display (FRD) that makes recording flow rates easier and more accurate
- Protection against vertical and transverse static overloading
- Flow rate comparator that indicates whether the flow rate is within the designated limits
- Tare memory function that saves the tare value in non-volatile memory
- Fast stabilization of approx. 1 second
- One touch calibration using internal weight (GX-A)
- Automatic self calibration to maintain accuracy under temperature changes (GX-A)
- Timed calibration function (GX-A)
- Clearly visible, reverse backlit LCD display
- Multiple weighing units: g, oz, lb, lb-oz, ozt, ct, mom, dwt, grain
- Clock and calendar function
- GLP/GMP/GCP/ISO compliant output to meet documentation requirements
- Universal Flexi Coms (UFC) function to edit serial data output/printout format
- Auto power ON and OFF functions

Specifications	GX-203A ●	GX-403A ●	GX-603A ●	GX-1003A ●	GX-1603A ●	GX-2002A	GX-4002A	GX-6002A	GX-6001A	GX-10001A ●
Price (ex GST)	\$2,260	\$2,580	\$3,210	\$4,060	\$4,320	\$2,260	\$2,580	\$3,520	\$1,890	\$2,110
Part Number	06053160	06053300	06053170	06053180	06053310	06053400	06053500	06053600	06053190	06053210
Price with NMI kit	\$2,380	\$2,700	\$3,330	N/A	N/A	\$2,380	\$2,700	\$3,640	\$2,010	N/A
Part Number	06053160-TA	06053300-TA	06053170-TA	N/A	N/A	06053400-TA	06053500-TA	06053600-TA	06053190-TA	N/A
Calibration	Internal calibration with internal mass									
Capacity	220g	420g	620g	1100g	1000g/1620g	2200g	4200g	6200g	6200g	10200g
Resolution	0.001g	0.001g	0.001g	0.001g	0.001g/0.002g	0.01g	0.01g	0.01g	0.1g	0.1g
Dimensions	212 (W) x 317(D) x 93(H) mm									
Pan Size	128mm x 128mm					165mm x 165mm				
Power Supply	AC Adaptor TB-S139 (included)									

● ex Japan

● These balances have breeze breaks included

Specifications	GF-203A ●	GF-403A ●	GF-603A ●	GF-1003A ●	GF-1603A ●	GF-2002A	GF-4002A ●	GF-6002A	GF-6001A	GF-10001A ●
Price (ex GST)	\$1,940	\$2,160	\$2,660	\$3,100	\$4,060	\$1,950	\$2,160	\$3,240	\$1,690	\$1,900
Part Number	06053220	06053230	06053800	06053240	06053320	06053250	06053260	06053150	06053270	06053280
Calibration	External manual calibration									
Capacity	220g	420g	620g	1100g	1000g/1620g	2200g	4200g	6200g	6200g	10200g
Resolution	0.001g	0.001g	0.001g	0.001g	0.001g/0.002g	0.01g	0.01g	0.01g	0.1g	0.1g
Dimensions	212 (W) x 317(D) x 93(H) mm									
Pan Size	128mm x 128mm					165mm x 165mm				
Power Supply	AC Adaptor TB-S139 (included)									

● ex Japan

● These balances have breeze breaks included

Accessories	Part Number	Price (ex GST)
Serial Cable DB9 Female to DB9 Female	03000007	\$60
OP-03 RS232C Host Interface	06053001	\$220
OP-04 Comparator relay output	06053006	\$540
OP-09 Built In Rechargeable Battery	06053002	\$690
OP-10 Large Glass Breeze Break	06053003	\$660
Protective Covers (pack of 5)	06053004	\$130
OP-12 Animal weigh pan	06053005	\$410



# GX-K / GF-K Series

## Industrial Precision Balances



Rugged Construction



Trade Approval  
NMI #6/4C/219  
(GX-K)



(GX-K)



(GF-K)



VFD Display



Percentage Function



RS-232C Interface



IP65



Super Hybrid Sensor



SmartRange



Date & Time



Animal Weighing



Comparator Function



Buzzer



Underhook



GLP Compliant



Software

### ● Free data capture software

- IP65 – Water and dust proof
- Fast response time with Super Hybrid Sensor (SHS) – only 1.5 seconds
- One touch Automatic calibration with motor-driven internal calibration mass (GX-K)
- Standard RS-232C Interface
- GLP, GMP and ISO compliant
- Automatic self calibration when the ambient temperature changes (GX-K)
- Underhook weighing (for thermal /magnetic samples, or density measurement)
- Display auto power off function

Specifications	GX-8K	GX-8K2	GX-10K	GX-20K	GX-30K	GF-8K	GF-10K	GF-12K	GF-30K
Price (ex GST)	\$4,820	\$3,680	\$5,030	\$4,790	\$5,660	\$4,580	\$4,920	\$4,430	\$5,300
Part Number	06062100	06062900	06062800	06062500	06062700	06062000	06062300	06062200	06062600
Price with NMI kit	\$4,950	N/A	\$5,150	\$4,910	\$5,780	N/A	N/A	N/A	N/A
Part Number	06062100-TA	N/A	06062800-TA	06062500-TA	06062700-TA	N/A	N/A	N/A	N/A
Calibration	Internal	Internal	Internal	Internal	Internal	External	External	External	External
Capacity	8.1kg	8.1kg / 2.1kg	10.1kg	21kg	31kg	8.1kg	10.1kg	12kg	31kg
Resolution	0.01g	0.1g / 0.01g	0.01g	0.1g	0.1g	0.01g	0.01g	0.1g	0.1g
NMI Resolution	0.1g	N/A	0.1g	1g	1g	N/A	N/A	N/A	N/A
Dimensions	300(W) x 355(D) x 111(H) mm								
Pan Size	270mm x 210mm								
Power Supply	AC Adaptor TB-S139 (included)								

NMI Versions also require trade verification - fees apply  
 ex Japan

Accessories	Part Number	Price (ex GST)
Serial Cable DB25 Male to DB9 Female	03000001	\$60
GFX/K OP-04 Comparator output and buzzer	06052504	\$540
GFX/K OP-06 Analog/current loop output	06052505	\$1,710
Protective Cover for GX/F-K (pack of 5)	AX-073007197-S	\$120



# GP Series

## Industrial Precision Balances



Trade Approval  
NMI #6/4C/220

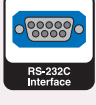

Option

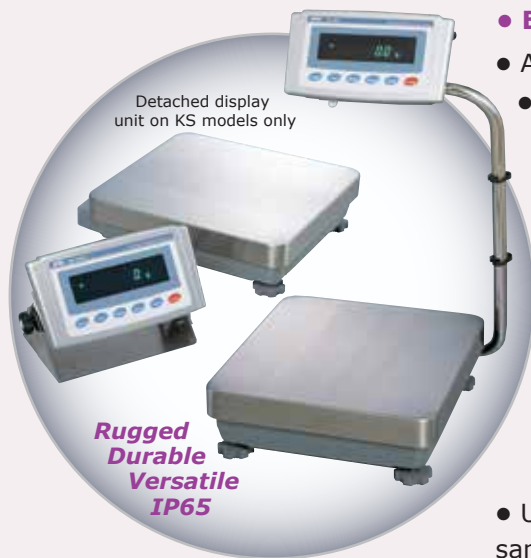

- Easy data capture with free WINCT software
- Australia's #1 Geo-test balance!
- Swing arm design or separate display design
  - IP65 protected
  - Easy calibration with internal calibration mass
  - SHS response speed of only 1.5 seconds
    - GLP, GMP and ISO compliant
    - Large Vacuum Fluorescent Display
    - Data memory function
    - Counting function with ACAI (Automatic Counting Accuracy Improvement)
  - Smart range (GP-32K/102K)
  - Comparator function
- Underhook weighing for thermal and magnetic samples as well as for density calculation



Remote switch option for GP Balance. This switch can also be used on a number of other balances. Please enquire.

Specifications	GP-12K	GP-20K	GP-32K	GP-32KS <span style="color:red">■</span>	GP-30K <span style="color:red">■</span>	GP-30KS <span style="color:red">■</span>
Price (ex GST)	\$5,180	\$5,910	\$5,410	\$5,790	\$6,490	\$6,490
Part Number	06072001	06072002	06072008	06072011	06072004	06072010
Price with NMI kit	\$5,300	\$6,030	\$5,530	\$5,900	\$6,610	\$6,610
Part Number	06072001-TA	06072002-TA	06072008-TA	06072011-TA	06072004-TA	06072010-TA
Calibration	Internal & External	Internal & External	Internal & External	Internal & External	Internal & External	Internal & External
Capacity	12kg	21kg	6kg/31kg	6kg/31kg	31kg	31kg
Resolution	0.1g	0.1g	0.1/1g	0.1/1g	0.1g	0.1g
NMI Resolution	1g	1g	1g	1g	1g	1g
Dimensions	372(W) x 615(D) x 130(H) mm					
Pan Size	384mm x 344mm			386mm x 346mm		
Power Supply	AC Adaptor TB-301 (included)					

NMI Versions also require trade verification - fees apply  
■ ex Japan

Specifications	GP-60K	GP-60KS <span style="color:red">■</span>	GP-61K	GP-61KS <span style="color:red">■</span>	GP-100K <span style="color:red">■</span>	GP-102K <span style="color:red">■</span>
Price (ex GST)	\$7,110	\$7,110	\$8,430	\$8,650	\$10,790	\$9,590
Part Number	06072014	06072012	06072009	06072013	06072006	06072007
Price with NMI kit	N/A	\$7,230	N/A	N/A	\$10,910	\$9,710
Part Number	N/A	06072012-TA	N/A	N/A	06072006-TA	06072007-TA
Calibration	Internal & External	Internal & External	Internal & External	Internal & External	Internal & External	Internal & External
Capacity	61kg	61kg	61kg	61kg	101kg	61kg/101kg
Resolution	1g	1g	0.1g	0.1g	1g	1g / 10g
NMI Resolution	N/A	10g	N/A	N/A	10g	10g / 100g
Dimensions	373(W) x 615(D) x 130(H) mm					
Pan Size	384mm x 344mm			386mm x 346mm		
Power Supply	AC Adaptor TB-301 (included)					

NMI Versions also require trade verification - fees apply  
■ ex Japan

Accessories	Part Number	Price (ex GST)
Serial Cable DB25 Male to DB9 Female	03000001	\$60
GP OP-04 Comparator Output/RS232C	06072104	\$540
GP OP-06 Analog / Current Loop Output <span style="color:red">●</span>	06052505	\$1,710
GP OP-20 Underhook (for GP12K/20K/32K/30K/40K)	06072120	\$450
GP OP-21 Underhook (for GP60K/100K/100KS/102K)	06072121	\$450
Remote switch option	LB	\$240
Plastic Cover for GP Display (Pack of 5)	10-73004753	\$120

● ex Japan

# HT Series

## Precision Compact Balances



HT-120 model

HT Compact scale



HT models have their own storage box.



Stainless Steel Pan Option

- HT-120 has hygienic and chemically resistant stainless steel (SUS304) weighing pan and protector plate
- HT-120 has resolution of 0.01 g with excellent repeatability of 0.01 g ( $\sigma$ )
- Large LCD display (15 mm character height) with clear white backlight
- Three colour bars to sort / colour code scales easily (except HT-120)
- Stackable carrying case for easy storage
- Security slot in the rear of the scale to accommodate an anti-theft lock
- HT-120 units: g, oz, ct, mom, ozt, grain, tola, tael, and Newton
- HT units: g, oz, ozt, tola, tael
- Auto-power off function to avoid wasting battery power
- Power supplied from 4 AA batteries
- Battery indicator that tells you the remaining battery level
- Tare function that offsets the weight of a container with just one key press
- Optional AC adaptor available



Stackable carry cases

Specifications	HT-120	HT-300	HT-500	HT-3000	HT-5000
Price (ex GST)	\$200	\$130	\$160	\$130	\$160
Part Number	06315000	06311000	06312000	06313000	06314000
Calibration	External	External	External	External	External
Capacity	120g	310g	510g	3100g	5100g
Resolution	0.01g	0.1g	0.1g	1g	1g
Dimensions	160(W) x 175(D) x 70(H)	195(W) x 136(D) x 44(H) mm			
Pan Size	Ø 70mm	132mm x 130mm			
Power Supply	AC Adaptor TB-S200A (not included) or 4 x AA batteries (included)				

Accessories	Part Number	Price (ex GST)
Stainless Steel Pan Option for standard HT Series	06311010	\$60
Optional AC Adaptor	ECTB-S200A	\$70
Carry Case (replacement)	06310103	\$30



# HT-CL Series

## Compact Packing Scales

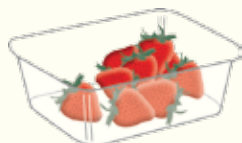

Quantity too small

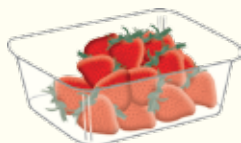

Quantity just right

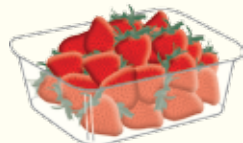

Quantity too large



- Highly-visible, multi-coloured LED lights for quick and unmistakable comparator judgements
- Operation with either four AA batteries or the provided AC adapter
- Large LCD display with 13.5-mm high characters
- Auto power off function to avoid wasting power
- Multiple weighing units: g, oz, ozt, lb-oz
- Security slot in the rear of the scale to accommodate an anti-theft lock
- Key lock function to prevent operators from making changes to the scale settings
- Comes in a stackable carrying case as standard to save space when stored
- Includes three colour bars (red, green and orange)



**Ideal for  
RAPID  
Punnet weighing!**



Carry Case  
(steel pan is optional)

Specifications	HT-500CL	HT-3000CL	HT-5000CL
Price (ex GST)	\$320	\$320	\$320
Part Number	06318000	06317000	06319000
Calibration	External	External	External
Capacity	510g	3100g	5100g
Resolution	0.1g	1g	1g
Dimensions	195(W) x 136(D) x 47(H) mm		
Pan Size	132mm x 130mm		
Power Supply	AC Adaptor TB-S200A (included) or 4 x AA batteries (not included)		

Accessories	Part Number	Price (ex GST)
Stainless Steel Pan Option for standard HT Series	06311010	\$60
AC Adaptor	ECTB-S200A	\$70
Carry Case (replacement)	06310103	\$30



# EJ Series Compact Scales



EJ breeze break



EJ-1500 model



EJ scales  
are stackable

- Counting, % weighing, comparator
- Calculates density automatically (option EJ-13)
- Hygienic and rustproof stainless steel pan
- Supports multiple weighing units
- Stackable body to save storage space
- Easy PC connection with optional RS232 cable
- EJ-27 and EJ-03 options cannot be used at the same time

OP-27: Wireless Bluetooth interface module available



Options

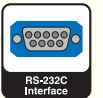

Specifications	EJ-210	EJ-410	EJ-610	EJ-1500	EJ-4100	EJ-6100
Price (ex GST)	\$530	\$700	\$830	\$530	\$710	\$830
Part Number	06044010	06044030	06044040	06044050	06044080	06044090
Calibration	External	External	External	External	External	External
Capacity	210g	410g	610g	1500g	4100g	6100g
Resolution	0.01g	0.01g	0.01g	0.1g	0.1g	0.1g
Dimensions	190(W) x 208(D) x 59(H) mm					
Pan Size	Ø110mm			127mm x 140mm		
Power Supply	4 x AA size batteries (not included) or AC Adaptor TB-S200A (included)					

Accessories	Part Number	Price (ex GST)
Serial Cable DB9 Female to DB9 Female	03000007	\$60
EJ OP-02 USB Interface (USB-A to USB-B connection cable not included)	06044001	\$170
USB-A to USB-B connection cable	03000011	\$60
EJ OP-03 RS-232C Interface	06044002	\$130
EJ OP-07 Underhook for EJ-4100/6100	06044003	\$100
EJ OP-08 Underhook for EJ-1500/2000	06044004	\$100
EJ OP-11 Tilting Breeze Break	06044005	\$130
EJ OP-12 Carry Case for EJ Series	06044006	\$180
EJ OP-13 Density Determination Kit (1mg & 10mg models only)	06044007	\$180
EJ OP-27 Wireless Bluetooth interface module*	06044008	\$190

\* EJ-27 and EJ-03 cannot be used at the same time and to be paired with either the AD-8541-PC or AD-8931



# EW-i Series

## Value Compact Balances



Trade Approval  
NMI #6/4C/230

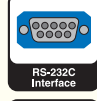

EW-1500i Balance

### • Free WINCT software available

- Advanced, triple range balances
- Capacities to 12kg
- Large back lit LCD display with wide viewing angle
- Standard RS232C data interface
- Overload protected to take hard use
- 9 built in weighing units plus counting and percentage software
- Standard comparator function with LO/GO/HI indication
- Full digital calibration with user definable calibration mass
- Conforms with GLP standards
- Stainless steel weighing pan
- Optional rechargeable battery pack
- Optional under hook weighing for 12kg model

### Options



**Weighing Range**  
(EW-i series only)  
Triple range indication

**ACAI**  
Automatic Counting  
Accuracy Improvement

**HI/OK/LO**  
Comparator Result

**Sample**  
Register a sample count or  
100% in percentage

**Print**  
Transmit data to printer  
or computer

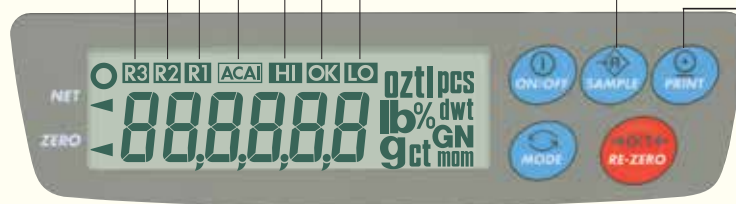

### Multi weighing units

- oz — Ounce (av)      g — Gram
- ozt — Troy Ounce    ct — Carat
- tl — Tael              mom — Momme
- lb — Livre (av)      pcs — Pieces
- GN — Grain unit    % — Percent
- dwt — Pennyweight

Specifications	EW-150i			EW-1500i			EW-12Ki		
Price (ex GST)	\$590			\$590			\$590		
Part Number	06043700			06043800			06043900		
Capacity	30g	60g	150g	300g	600g	1500g	3000g	6000g	12Kg
Resolution	0.01g	0.02g	0.05g	0.1g	0.2g	0.5g	1g	2g	5g
Price with NMI kit	\$710			\$710			\$710		
Part Number	06043700-TA			06043800-TA			06043900-TA		
Capacity	60g	150g		300g	600g	1500g	3000g	6000g	12Kg
Resolution	0.02g	0.05g		0.1g	0.2g	0.5g	1g	2g	5g
Dimensions	190(W) x 218(D) x 55(H) mm			190(W) x 218(D) x 53(H) mm					
Pan Size	Ø 110mm			133 mm x 170 mm					
Power Supply	AC Adapter TB-S200A (included) or rechargeable battery pack (not included)								

\*NMI Versions also require trade verification - fees apply

Accessories	Part Number	Price (ex GST)
Serial Cable DB9 Female to DB9 Female	03000007	\$60
EKWi OP-04 Comp/Relay Output	06043001	\$340
EKWi OP-07 Underhook for 6000g/12kg models only	06041004	\$90
EKWi OP-09 Rechargeable battery pack Ni-MH (Approx. 9 hrs)	06043003	\$340
Protective Cover for EKWi (pack of 5)	AX-3005824-5S	\$90



# EK-i Series

## Industrial Compact Balances



Trade Approval  
NMI #6/4C/243

*Trade Approved & Great Value!*

- Free downloadable WinCT software available

- NMI Models (EK-410i, EK-610i, EK-4100i, EK-6100i)
- Standard RS-232C interface
- Large LCD display with backlight
- GLP compliance
- Overload protection
- Standard comparator function
- Optional rechargeable battery pack



EK Battery Pack Option

- 9 Weighing units plus count and percentage mode
- Counting function with automatic counting accuracy improvement (ACAI)



EK-i Balance

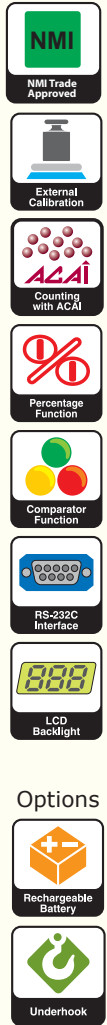

Options

Specifications	EK-410i	EK-610i	EK-3000i	EK-4100i	EK-6100i	EK-6000i	EK-12Ki
Price (ex GST)	\$880	\$1,060	\$830	\$880	\$1,060	\$880	\$1,060
Part Number	06042101	06042201	06043400	06042301	06042401	06043500	06043600
Capacity	400g	600g	3000g	4000g	6000g	6000g	12kg
Resolution	0.01g	0.01g	0.1g	0.1g	0.1g	1g	1g
Price with NMI kit	\$990	\$1,180	N/A	\$990	\$1,180	N/A	N/A
Part Number	06042101-TA	06042201-TA	N/A	06042301-TA	06042401-TA	N/A	N/A
Capacity	400g	600g	N/A	4000g	6000g	N/A	N/A
Resolution	0.1g	0.1g	N/A	1g	1g	N/A	N/A
Calibration	External	External	External	External	External	External	External
Dimensions	190(W) x 218(D) x 55(H)						
Pan Size	Ø 110mm		133mm x 170mm				
Power Supply	AC Adaptor TB-S200A (included) or rechargeable battery pack (not included)						

NMI Versions also require trade verification - fees apply

Accessories	Part Number	Price (ex GST)
Serial Cable DB9 Female to DB9 Female	03000007	\$60
EKWi OP-04 Comp/Relay Output	06043001	\$340
EKWi OP-07 Underhook for 6000g/12kg models only	06041004	\$90
EKWi OP-09 Rechargeable battery pack Ni-MH (Approx. 9 hrs)	06043003	\$340
Protective Cover for EKWi (pack of 5)	AX-3005824-5S	\$90



# EK-L Series

## Compact Industrial Precision Scales

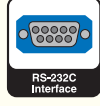

Options



**Bright LCD Screen**  
**22mm Character height**

- Stainless steel SUS430 weighing pan cover
- Multiple weighing units: g, kg, oz, lb, ozt
- Percentage Counting and Comparator function
- Easy-to-read LCD display with clear, white backlight
- Counting mode with Automatic Counting Accuracy Improvement (ACAI) function
- RS-232C interface as standard
- Display hold function
- GLP, GMP and ISO compliance
- Battery life indicator

Specifications	EK-15KL	EK-30KL	
Price (ex GST)	\$1,060	\$1,060	
Part Number	06045100	06045200	
Calibration	External	External	
Capacity	15kg	3kg	30kg
Resolution	0.1g	0.1g	1g
Dimensions	315(W) x 339 (D) x 130(H) mm		
Pan Size	300mm x 210 mm		
Power Supply	AC Adaptor TB-S200A (included) or rechargeable battery (not included)		

Accessories	Part Number	Price (ex GST)
Serial Cable DB9 Female to DB9 Female	03000007	\$60
Rechargeable Battery option (Approx. 100hrs with backlight off)	ECEB-6V	\$25

# SJ-HS Series

## Compact Bench Scales



Trade Approval  
NMI #6/4C/278

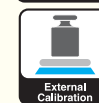

- Stainless steel weighing pan
- High speed weighing in less than 1 second
- Multiple weighing units – g, lb, oz and lb-oz
- Level bubble and adjustable feet for precise levelling
- AC adapter or Battery (powers up to 2000 hours)
- Removable stainless steel weighing platform and molded plastic construction are easy-to-clean

## NON TRADE MODELS

Specifications	SJ-1000HS	SJ-2000HS	SJ-5000HS	SJ-12KHS	SJ-5001HS	SJ-20KHS	SJ-30KHS
Price (ex GST)	\$300	\$300	\$300	\$300	\$330	\$330	\$330
Part Number	06303040	06304050	06304060	06304070	06304080	06305000	06305010
Calibration	External	External	External	External	External	External	External
Capacity	1000g	2000g	5000g	12kg	5000g	20kg	30kg
Resolution	0.5g	1g	2g	5g	1g	10g	20g
Dimensions	265(W) x 250(D) x 106(H) mm						
Pan Size	230mm x 190mm						
Power Supply	AC Adaptor TB-S200A (included) or 4 x D size batteries (not included)						

## TRADE APPROVED MODELS

Specifications	SJ-1000N	SJ-2000N	SJ-5000N	SJ-12KN
Price with NMI kit	\$330	\$330	\$330	\$330
Part Number	06303000	06303010	06303020	06303030
Calibration	External	External	External	External
Capacity	1000g	2000g	5000g	10kg / 12kg
Resolution	1g	2g	5g	10g / 20g
Dimensions	265(W) x 250(D) x 106(H) mm			
Pan Size	230mm x 190mm			
Power Supply	AC Adaptor TB-S200A (included) or 4 x D size batteries (not included)			



4 x D size batteries

NMI Versions also require trade verification - fees apply

Accessories	Part Number	Price (ex GST)
Replacement stainless steel feet (set of 4)	1074018232-SFS	\$45



# SJ-WP MK2 / SJ-WP-BT Series

## Waterproof Packing Scales

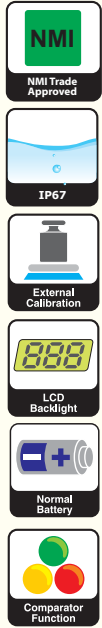

Trade Approval  
NMI #6/4C/312



**SJ-WP improves packing efficiency compared to standard scales**

- Bluetooth models available
- 5000hrs of continuous operation on 6D cell batteries
- Fast stabilisation (just 0.5 seconds!)
- 10 comparator setting IDs
- Tactile keys and stainless weighing pan
- Submersible IP67 protection
- Large & Clear LCD Display (26mm)
- Multiple selectable weighing units: g, lb, oz, ozt, tael etc.
- Bright and multicoloured LED comparator lamps
- Trade Approved models come with trade approved stickers

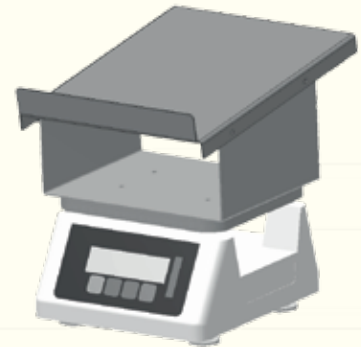

**Packing scale frame kit (option)**

MK2 Models	SJ-3000WP MK2	SJ-6000WP MK2	SJ-15KWP MK2	SJ-30KWP MK2
Price (ex. GST)	\$530	\$530	\$530	\$530
Part Number (MK2)	06305700	06305800	06305900	06306000
Bluetooth Models	SJ-3000AWP-BT	SJ-6000AWP-BT	SJ-15KAWP-BT	SJ-30KAWP-BT
Price (ex. GST)	\$640	\$640	\$640	\$640
Part Number (BT)	06306100	06306200	06306300	06306400
Capacity	3000g	6000g	15kg	30kg
Resolution	standard 0.5g high 0.1g	standard 1g high 0.2g	standard 2g high 0.5g	standard 5g high 1g
NMI Resolution	1.5kg / 3kg 0.5g / 1g	3kg / 6kg 1g / 2g	6kg / 15kg 2g / 5g	15kg / 30kg 5g / 10g
Dimensions	236(W) x 260(D) x 148(H) mm			
Pan Size	232mm x 192mm			
Power Supply	6 x D size batteries			

NMI Versions also require trade verification - fees apply

Accessories	Part Number	Price (ex GST)
Replacement stainless steel feet (set of 4)	1074018232-SFS	\$45
Packing scale frame kit	06305610	\$170
AD-8541-PC Bluetooth convertor for PC	09024030	\$200
AD-8931 Wireless remote display (26mm digits)	06086710	\$200



# SK-WP Series

## Stainless Steel Bench Scales



Trade Approval  
NMI #6/4C/216



- **NMI Trade Approved except for SK-5001WP**
- Trade Approved models supplied as standard
- Dust and water proof (IP65)
- Stainless steel body and Weighing Pan
- Large & Clear LCD Display (25mm)
- 1/2000 Resolution (SK-5001WP: 1/5000)
- Net Weight / Stability Indication
- Portable (6 x D Type Batteries not included)
- Long battery life: Approx. 1200 hrs with alkaline cells at 20°C

Specifications	SK-1000WP	SK-2000WP	SK-5000WP	SK-5001WP	SK-10KWP	SK-20KWP
Price (ex GST)	\$640	\$640	\$640	\$640	\$640	\$640
Part Number	06400100	06400200	06400300	06400600	06400400	06400500
Capacity	1000g	2000g	5000g	5000g	10000g	20000g
Resolution	0.5g	1g	2g	1g	5g	10g
Dimensions	266(W) x 280(D) x 156(H) mm					
Pan Size	232mm x 192mm					
Power Supply	AC Adaptor TB-S200A (included) or 6 x D size batteries (not included)					

\*NMI Versions also require trade verification - fees apply

# HL-WP Series

## Professional Catering Scales



- Body made of stainless steel and protected to IP-65
- Only HL-3000LWP comes with larger flat pan
- Clear Liquid Crystal Display (LCD)

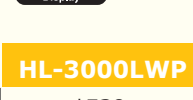

**IP65 Water & Dust Protection!**

Specifications	HL-300WP	HL-1000WP	HL-3000WP	HL-3000LWP
Price (ex GST)	\$510	\$510	\$510	\$530
Part Number	06410100	06410200	06410300	06410400
Capacity	300g	1000g	3000g	3000g
Resolution	0.1g	0.5g	1g	1g
Dimensions	170(W) x 220(D) x 63(H) mm			174(W) x 220(D) x 63(H) mm
Pan Size	128mm x 128mm			174 x 137mm
Power Supply	6 x AA size batteries (included) or AC Adaptor TB-S200A (not included)			



**Hazardous area weighing doesn't have to end in tears.**

## ***Safety Matters.***

Intrinsically Safe IECEx / ATEX Scales.

**Certificate No: IECEx FMG 15.0006X**

**Certificate No: IECEx FMG 17.0018X**

Full Certificate Details at:

**[www.andweighing.com.au/latest-news/iecex](http://www.andweighing.com.au/latest-news/iecex)**



*HV-CEP Indicators  
are NOT sold separately.*



# EK-EP Series

## Intrinsically Safe Compact Balances



Certificate No.  
**IECEX FMG 15.0006X**

Full Certificate Details at:  
[www.andweighing.com.au/latest-news/iecex](http://www.andweighing.com.au/latest-news/iecex)

- IECEx compliant, ideal for hazardous area weighing.
- Easy to read LCD display with backlight (16mm character height)
- Chemically resistant stainless steel SUS430 weighing pan.
- Comparator function for faster filling, packing, sorting
- ACAI Automatic counting accuracy improvement

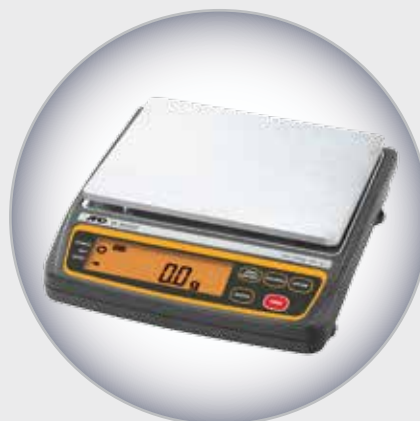

Specifications	EK-300EP	EK-3000EP	EK-12KEP
Price (ex GST)	\$1,660	\$1,660	\$1,660
Part Number	06046100	06046200	06046300
Capacity	300g	3000g	12kg
Resolution	0.01g	0.1g	1g
Dimensions	190(W) x 218(D) x 54(H) mm	190(W) x 218(D) x 53(H) mm	
Pan Size	Ø 110mm	133 mm x 170 mm	
Power Supply	4 x AA batteries* (Approx. 250hrs)		

\*DURACELL AA alkaline MN1500 LR6, ENERGIZER AA E91 alkaline LR6 AM3, PANASONIC AA alkaline LR6 (XJ) 1.5V batteries

Accessories	Part Number	Price (ex GST)
Carry Case	06044006	\$180
Protective cover (pack of 5)	AX-3005824-5S	\$90

# HV-CEP Series

## Explosion Proof Platform Scales



Certificate No.  
**IECEX FMG 17.0018X**

Full Certificate Details at:  
[www.andweighing.com.au/latest-news/iecex](http://www.andweighing.com.au/latest-news/iecex)



- Auto-tare and negative comparison function
- Counting mode and accumulation function
- Highly-visible, LCD display with white backlight
- Bright and multi-coloured 5-step LED comparator lights



- IECEx / ATEX internationally certified scales
- Easy settings using the alphanumeric keypad

Specifications	HV-15KCEP	HV-60KCEP	HV-200KCEP
Price (ex GST)	\$3,130	\$3,490	\$4,090
Part Number	03052500	03052501	03052502
Capacity	3kg / 6kg / 15kg	15kg / 30kg / 60kg	60kg / 150kg / 220kg
Resolution	0.001kg / 0.002kg / 0.005kg	0.005kg / 0.01kg / 0.02kg	0.02kg / 0.05kg / 0.1kg
Dimensions	250(W) x 397(D) x 439(H) mm	330(W) x 585(D) x 776(H) mm	390(W) x 691(D) x 776(H) mm
Pan Size	250 x 250 mm	330 x 424 mm	390 x 530 mm
Power Supply	4 x D size batteries* 1.5 V		

\*Up to 1500 hours with LED and backlight off; Up to 1000 hours with LED and backlight on



# EM Series

## Value Parcel Scales

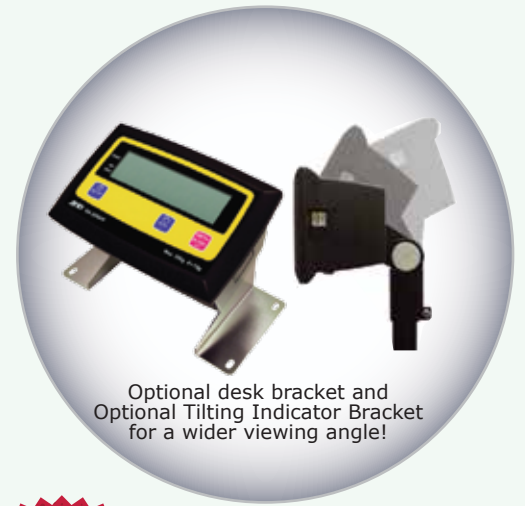

Optional desk bracket and Optional Tilting Indicator Bracket for a wider viewing angle!



**Extra discounts for BULK orders!**

- **Three selectable resolutions - Fine, Super-fine, Standard (Default is FINE)**
- High Resolution Mode Selectable: 5g Accuracy on EM-30KAM, 10g Accuracy on EM-60KAL, 20g Accuracy on EM-150KAL
- Clearly Visible Display with White Backlight
- Portable Lightweight Body
- Auto Power Off (scale switches off automatically after a period of inactivity)
- Rotating Indicator (to improve viewing display from the back or side)
- Two Platform Sizes (300 x 350 mm and 400 x 500 mm)
- Convenient Counting Function (able to count the number of objects with the same weight, based on a predetermined unit weight)
- For scales that have not been used for a considerable length of time, the rechargeable batteries should be re-charged prior to use.

Specifications	EM-30KAM	EM-60KAL	EM-150KAL
<b>Price (ex GST)</b>	<b>\$360</b>	<b>\$420</b>	<b>\$420</b>
<b>Part Number</b>	<b>06500300</b>	<b>06500200</b>	<b>06500100</b>
Calibration	External	External	External
Capacity	30kg	60kg	150kg
Adjustable Resolution	2g / 5g / 10g	5g / 10g / 20g	10g / 20g / 50g
Dimensions	300(W)x560(D)x450(H)	400(W) x 500(D) x 750(H)	
Pan Size	300mm x 350mm	400mm x 500mm	
Power Supply	AC Adaptor TB-S200A and internal rechargeable battery (included)		

Accessories	Part Number	Price (ex GST)
Serial Cable DB9 Female to DB9 Female	03000007	\$60
EM OP-03 RS232 Interface (to be factory fitted only)	06500011	\$70
Option OP-03 includes factory fitting charge, soldering required.	LB	\$30
EM OP-12 Tilting Indicator Bracket	06500012	\$70
EM OP-14 Desktop stand	06500013	\$70
EM OP-17 5m Loadcell extension cable	06500014	\$70
Rechargeable battery (Approx. 200 hours)	1EBGFP620	\$40

# FG Series Platform Scales



Floor Platform and  
Bench Mount  
models!

FG-150KAL



FG-60KBM

Trade Approval  
NMI #6/9C/289



Options



- **NMI Trade Approved except for Hi-Res 31K model**
- Trade Approved models supplied as standard
- Three selectable weighing resolutions
- Display column and Tilt display pod (FG-KA only)
- Optional RS-232C and Comparator Output (FG-23/FG24)

- Comparator function
- Filtering function
- Full digital calibration
- External Calibration

Specifications	FG-30KAM	FG-30KBM	FG-60KAM	FG-60KBM	FG-150KAM
Price (ex GST)	<b>\$870</b>	<b>\$870</b>	<b>\$870</b>	<b>\$870</b>	<b>\$870</b>
Part Number	<b>03175700</b>	<b>03175750</b>	<b>03175710</b>	<b>03175760</b>	<b>03175720</b>
Calibration	External	External	External	External	External
Capacity	30kg	30kg	60kg	60kg	150kg
Resolution NMI Approved	0.01kg	0.01kg	0.02kg	0.02kg	0.05kg
Adjustable Resolution	2g/5g/10g	2g/5g/10g	5g/10g/20g	5g/10g/20g	10g/20g/50g
Dimensions	KAM: 300(W) x 624(D) x 781(H); KBM: 380(W) x 464(D) x 118(H) mm				
Pan Size	300mm x 380mm				
Serial Cable	DIN Male to DB9 Female (03000002)				
Power Supply	AC Adaptor TB-S200A (incl.) or 4 x C size batteries (not incl. Approx. 150 hrs)				

\*NMI Versions also require trade verification - fees apply

Specifications	FG-31KAM	FG-31KBM	FG-60KAL	FG-150KAL	FG-150KBM
Price (ex GST)	<b>\$1,040</b>	<b>\$1,040</b>	<b>\$920</b>	<b>\$920</b>	<b>\$870</b>
Part Number	<b>03175790</b>	<b>03175780</b>	<b>03175730</b>	<b>03175740</b>	<b>03175770</b>
Calibration	External	External	External	External	External
Capacity	30kg	30kg	60kg	150kg	150kg
Resolution NMI Approved	<b>non NMI approved models</b>		0.02kg	0.05kg	0.05kg
Adjustable Resolution	1g		5g/10g/20g	10g/20g/50g	10g/20g/50g
Dimensions	KAM: 300(W)x624(D)x781(H); KBM: 380(W)x464(D)x118(H); KAL: 390(W)x771(D)x781(H) mm				
Pan Size	300mm x 380mm		390mm x 530mm		300mm x 380mm
Serial Cable	DIN Male to DB9 Female (03000002)				
Power Supply	AC Adaptor TB-S200A (incl.) or 4 x C size batteries (not incl. Approx. 150 hrs)				

\*NMI Versions also require trade verification - fees apply

Accessories	Part Number	Price (ex GST)
Serial Cable DIN Male to DB9 Female	03000002	\$60
FG-23 RS232 Interface option	06145101	\$240
FG-24 RS232 Interface & Comparator option	06145102	\$260



# HVW-C / HVW-CP Series

## Multi-functional Platform Scales

**NMI** Trade Approval (HV Only)  
NMI #6/9C/317

**NMI Trade Approved**

Accumulation Function  
Counting Function  
Ticket Formatting

Percentage Function  
GLP Compliant  
LCD Backlight

Date & Time  
External Calibration  
Comparator Function

Software  
IP65 (Base)



### Option

RS-232C Interface

USB Interface

- Bright and multi-coloured 5-step LED comparator lights
- Auto-tare and negative comparison function
- Highly-visible, LCD display with white backlight
- Universal Flexi Coms (UFC) function
- Quick and easy settings using the alphanumeric keypad
- Built-in thermal printer for the HV/HW-CP series
- IP65 dust & waterproof base with a stainless steel (SUS430) pan
- Three slots for optional data communication interfaces
- *Bluetooth interface module coming soon*



Thermal printer in HV/HW-CP models

Specifications	HV-15KC	HV-60KC	HV-200KC	HV-15KCP	HV-60KCP	HV-200KCP
Price (ex GST)	\$1,100	\$1,190	\$1,360	\$1,340	\$1,430	\$1,600
Part Number	03152300	03152400	03152500	03152301	03152401	03152501
Calibration	External			External		
Capacity	3kg/6kg/15kg	15kg/30kg/60kg	60kg/150kg/220kg	3kg/6kg/15kg	15kg/30kg/60kg	60kg/150kg/220kg
Resolution	1g/2g/5g	5g/10g/20g	20g/50g/100g	1g/2g/5g	5g/10g/20g	20g/50g/100g
Dimensions	275(W)x474(D)x368(H)	330(W)x621(D)x771(H)	390(W)x712(D)x773(H)	275(W)x474(D)x368(H)	330(W)x621(D)x771(H)	390(W)x712(D)x773(H)
Pan Size	250mm x 250mm	330mm x 424mm	390mm x 530mm	250mm x 250mm	330mm x 424mm	390mm x 530mm
Includes Printer	No			Includes Built-in Printer		
Power Supply	AC Adaptor TB-S200A (included) or 4 x D size batteries (not included)			AC Adaptor TB-S200A (included)		

Specifications	HW-10KC	HW-60KC	HW-200KC	HW-10KCP	HW-60KCP	HW-200KCP
Price (ex GST)	\$1000	\$1,090	\$1,250	\$1,230	\$1,320	\$1,490
Part Number	03162100	03162200	03162300	03162101	03162201	03162301
Calibration	External			External		
Capacity	10kg	60kg	220kg	10kg	60kg	220kg
Resolution	1g	5g	20g	1g	5g	20g
Dimensions	275(W)x474(D)x368(H)	330(W)x621(D)x771(H)	390(W)x712(D)x773(H)	275(W)x474(D)x368(H)	330(W)x621(D)x771(H)	390(W)x712(D)x773(H)
Pan Size	250mm x 250mm	330mm x 424mm	390mm x 530mm	250mm x 250mm	330mm x 424mm	390mm x 530mm
Includes Printer	No			Includes Built-in Printer		
Power Supply	AC Adaptor TB-S200A (included) or 4 x D size batteries (not included)			AC Adaptor TB-S200A (included)		

Accessories	Part Number	Price (ex GST)
Serial Cable DB9 Female to DB9 Female	03000007	\$60
HV/HW-03C OP-03 RS232C interface	03152320	\$125
HV/HW-02C OP-02 USB interface	03152310	\$130
HV/HW-04C OP-04 Comparator relay interface	03152330	\$355
HV/HW-11C Wall mount bracket	03152340	\$230
HV/HW-13 large roller conveyor (for 200kg model)	03152604	\$730
HV/HW-14 medium roller conveyor (for 60kg model)	03152603	\$730
HV/HW-C Paper rolls (Pack of 5)	AX-PP147-S	\$100



# HV-CWP Series

## Waterproof Platform Scales

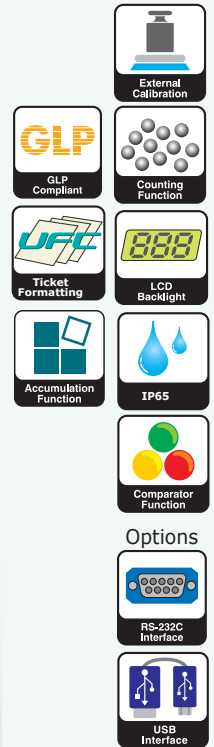

Bright 5-step LED comparator lights.



IP65 Rated Platform Scale

- IP65 dust & waterproof with SUS304 surface
- High speed measurements (1 second)
- Counting mode and accumulation function
- Freely adjustable display angle
- Auto-tare and negative comparison function
- Quick and easy settings using the alphanumeric keypad
- Bright and multi-coloured 5-step LED comparator lights
- *Bluetooth interface module coming soon*

Specifications	HV-15KCWP	HV-60KCWP	HV-200KCWP
Price (ex GST)	\$2,030	\$2,240	\$2,480
Part Number	03152600	03152700	03152800
Capacity	3 / 6 / 15kg	15 / 30 / 60kg	60 / 150 / 220kg
Resolution	0.001 / 0.002 / 0.005kg	0.005 / 0.01 / 0.02kg	0.02 / 0.05 / 0.1kg
Dimensions	250(W) x 470(D) x 430(H) mm	330(W) x 616(D) x 752(H) mm	390(W) x 722(D) x 752(H) mm
Pan Size	250 x 250 mm	330 x 424 mm	390 x 530 mm
Power Supply	AC Mains (100-240 V)		

Accessories	Part Number	Price (ex GST)
Serial Cable Wire connection for terminal to DB9 Female	03000004	\$60
HV-CWP OP-03 RS232C interface	03152602	\$310
HV-CWP OP-02 USB interface	03152601	\$120
HV-CWP OP-04 Comparator output	03152605	\$345



# SE Series

## IP68 Washdown Platform Scales



Trade Approval  
NMI #6/4C/276



### Options



**NEW!** SE-150KL-W Wall Mount scale



Caster wheels and lock option for SE/SC scales (4 wheels)

Push handle option available  
Enquire with Account Manager

- **Trade Approved model supplied as standard**
- Water/Dust proof for less than a dry area scale!
- Washdown IP68 construction for easy cleaning
- High speed stabilization of 1 second
- Battery operated (Approx. 5000 hours without RS-232)
- Supersized LCD of 39 mm character height
- Corrosion-resistant load cell (Aluminium anodized and coated with epoxy resin with protective silicon over wiring)
- Comparator function, Counting function, Automatic power off
- AC Power Adaptor option available (*for non trade models only*)
- *Bluetooth interface module available now*

Specifications	SE-30KAM	SE-60KAM	SE-150KAM	SE-60KAL	SE-150KAL	SE-150KL-W
Price (ex GST)	\$940	\$940	\$940	\$940	\$940	\$840
Part Number	06160900	06161000	06160100	06160300	06160200	06160201
Calibration	External	External	External	External	External	External
Capacity	30kg	60kg	150kg	60kg	150kg	150kg
Resolution NMI Approved	10g	20g	50g	20g	50g	N/A
Adjustable Resolution	5g/10g	10g/20g	20g/50g	10g/20g	20g/50g	20g/50g
Dimensions	300(W) x 543(D) x 717(H) mm			390(W) x 688(D) x 717(H) mm		
Pan Size (SUS430)	300mm x 380mm			390mm x 530mm		
Power Supply	6 x D size batteries (included)					

\*NMI Versions also require trade verification - fees apply

Accessories	Part Number	Price (ex GST)
Serial Cable Wire connection for terminal to DB9 Female	03000004	\$60
SCSE OP-02 Quick USB Interface (cable not included)	06160401	\$240
SCSE OP-03 RS-232C + Comparator relay output	06160402	\$350
SC-D Indicator only (bracket not included) <i>Non Trade Indicator</i>	06163800	\$540
SCSE OP-04 wall mount bracket	06163810	\$100
SCSE Four caster wheels & lock option	06160408	\$160
AC power adaptor option	06160510	\$180
(NB: <i>non trade only and with the adaptor the scale becomes IP65</i> )		
SCSE Bluetooth Interface	06160410	\$195



# SC Series

## IP68 Washdown Platform Scales



SUS304 Stainless steel frame and weigh pan

**Excellent  
Resistance  
to Hostile  
Environments!**



Trade Approval  
NMI #6/4C/276

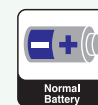

Options

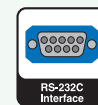

- **Trade Approved model is supplied as standard**
- Water/Dust proof for less than a dry area scale!
- Washdown construction for easy cleaning
- Battery operated (Approx. 5000 hours or 2500 hours if RS-232 is used)
- IP68 dust and water-proof: Submersible! (1m under water for 24 hours!)
- Frame and weigh pan is stainless steel SUS304
- Supersized LCD of 39 mm character height
- AC Power Adaptor option available (*for non trade models only*)
- Comparator function, Counting function, Automatic power off
- Corrosion-resistant load cell (Aluminium anodized and coated with epoxy resin; protective silicon over wiring)
- Indicator SC-D is also sold separately. (*Refer to indicators page*)
- *Bluetooth interface module available now*

Specifications	SC-30KAM	SC-60KAM	SC-150KAM	SC-60KAL	SC-150KAL
Price (ex GST)	\$1,730	\$1,730	\$1,730	\$1,840	\$1,840
Part Number	06160800	06160400	06160500	06160600	06160700
Calibration	External	External	External	External	External
Capacity	30kg	60kg	150kg	60kg	150kg
Resolution NMI Approved	10g	20g	50g	20g	50g
Adjustable Resolution	5g/10g	10g/20g	20g/50g	10g/20g	20g/50g
Dimensions	300(W) x 543(D) x 717(H) mm			390(W) x 688(D) x 717(H) mm	
Pan Size (SUS304)	300mm x 380mm			390mm x 530mm	
Power Supply	6 x D size batteries (included)				

\*NMI Versions also require trade verification - fees apply

Accessories	Part Number	Price (ex GST)
Serial Cable Wire connection for terminal to DB9 Female	03000004	\$60
SCSE OP-02 Quick USB Interface (cable not included)	06160401	\$240
SCSE OP-03 RS-232C + Comparator relay output	06160402	\$350
SC-D Indicator only (bracket not included) <i>Non Trade Indicator</i>	06163800	\$540
SCSE OP-04 wall mount bracket	06163810	\$100
SCSE Four caster wheels & lock option	06160408	\$160
AC power adaptor option (non trade only and with the adaptor the scale becomes IP65)	06160510	\$180
SCSE Bluetooth Interface	06160410	\$195



# SW Series

## Super Wash Down Scales



Trade Approval  
NMI #6/4C/274



Options

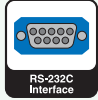

SW Bracket Option



Cleaning with pressurized jet

Stainless steel sensor

Withstands extremely damp environments

### NMI TRADE APPROVED

IP69K Stainless steel  
Check weighing applications  
Food applications  
Ergonomic design



5-level comparator lamps

- Trade approved model supplied as standard
- Ultimate protection against the effects of condensation as well as water
- Stainless steel weighing pan, frame and load cell
- Rugged and adjustable (0°, 30°, 60° or 90°) indicator bracket
- Touch sensitive capacitive keys to prevent damage from sharp objects
- Auto-tare function to facilitate consecutive check weighing
- Bright, multicoloured LED display with 5-step comparator lamps
- Frame and weigh pan are stainless steel SUS304 and loadcell is SUS630
- Three sizes of base units, which are also available separately
- Pole stand attachable to either the short or long side of the platform
- The display unit available separately as an IP69K indicator for high pressure washdown

Specifications	SW-6KS	SW-15KS	SW-15KAM	SW-30KAM	SW-60KAM	SW-150KAM	SW-60KAL	SW-150KAL
Price (ex GST)	\$2,370	\$2,370	\$2,960	\$2,960	\$2,960	\$2,960	\$3,540	\$3,540
Part Number	06161100	06161800	06161200	06161300	06161400	06161500	06161600	06161700
Calibration	External	External	External	External	External	External	External	External
Capacity	6kg	15kg	15kg	30kg	60kg	150kg	60kg	150kg
Resolution NMI Approved	2g	5g	5g	10g	20g	50g	20g	50g
Adjustable Resolution	0.5g/1g/2g	1g/2g/5g	1g/2g/5g	2g/5g/10g	5g/10g/20g	10g/20g/50g	5g/10g/20g	10g/20g/50g
Dimensions	250(W)x480(D)x354(H)			300(W)x601(D)x723(H) mm			390(W)x751(D)x723(H)	
Pan Size (SUS304)	250mm x 250mm			300mm x 380mm			390mm x 530mm	
Power Supply	Rechargeable battery (included)							

\*NMI Versions also require trade verification - fees apply

Accessories	Part Number	Price (ex GST)
Serial Cable Wire connection for terminal to DB9 Female	03000004	\$60
SW OP-03 RS-232C serial interface + comparator output	06162001	\$400
SW OP-04 RS422/485 interface	06162002	\$400
SW OP-11 Bench/Wall bracket	06162004	\$240
SW-D Indicator display (without bracket) <i>Non Trade Indicator</i>	06162100	\$1450
Rechargeable Battery (Approx. 90hrs)	ECEB-6V-YUASA	\$50

# FS-Ki Series

## Checkweighing IP65 Scales



**Ultra fast weighing response  
Just 0.5 seconds!**



Trade Approval  
NMI #6/4C/250

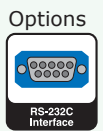
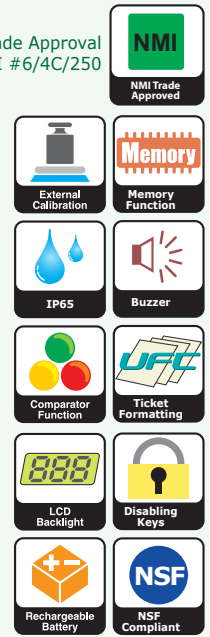

- Trade Approved model supplied as standard (except for FS-60Ki, FS-150Ki)
- Analog sweep display - 3 modes
- Memory for 99 products
- Large LCD display with backlight
- Numeric keypad for easy programming
- IP65 Dust and Waterproof
- Large comparator lights & Buzzer
- Comparator function with LO, HI or OK

Large column (550mm)  
option shown here with  
regular column (300mm)



Specifications	FS-6Ki	FS-15Ki	FS-15Ki-L	FS-30Ki	FS-60Ki	FS-150Ki
Price (ex GST)	\$1,800	\$1,800	\$2,050	\$2,050	\$2,420	\$2,420
Part Number	03078000	03078010	03078030	03078020	03078060	03078070
Calibration	External	External	External	External	External	External
Capacity	6kg	15kg	15kg	30kg	60kg	150kg
Resolution NMI Approved	0.002kg	0.005kg	0.005kg	0.01kg	N/A	N/A
Adjustable Resolution	0.5g/1g/2g	1g/2g/5g	1g/2g/5g	2g/5g/10g	10g/20g/50g	20g/50g/100g
Dimensions	250(W) x 414(D) x 496(H)mm		380(W) x 464(D) x 496(H)mm		380(W) x 740(D) x 740(H)mm	
Pan Size	250mm x 250mm		380mm x 300mm		530mm x 390mm	
Power Supply	AC Mains (included) or rechargeable battery (included)					

\*NMI Versions also require trade verification - fees apply

Accessories	Part Number	Price (ex GST)
Serial Cable Wire connection for terminal to DB9 Female	03000004	\$60
FS OP-03i RS232 + Relay Output	03078001	\$290
FS OP-04i RS422/485 + Relay Output	03078002	\$350
Rechargeable Battery (Approx. 80 hrs)	ECEB-6V	\$40
FS-D Wall Mounting Bracket	MC07042.005	\$80
FS-D Indicator Display (bracket included) <i>Non Trade Indicator</i>	06132500	\$1520
FS Large Column option (550mm)	03078004	\$310



# Portable Scale & Baseworks

## SA Series, SB Base, SC Base, SW Base

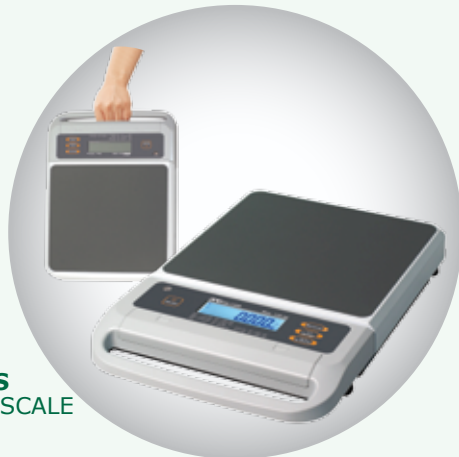

**SA SERIES**  
PORTABLE SCALE

- One scale for both precise 0.001 kg / 1g readability and up to 3 kg/3000 g (smart range), and high-capacity weighing
- LCD display with backlight (24 mm character height), Which is 180-degrees reversible
- Easy to carry around to use at various locations
- Low profile (approx. 73 mm) that can be stored in narrow spaces or propped against a wall
- Four weighing ranges (readabilities) selectable
- Auto power ON/OFF function
- Battery life indicator
- Optional RS-232 output

Specifications	SA-30K	SA-60K	SA-150K
Price (ex GST)	\$1,050	\$1,050	\$1,050
Part Number	06330300	06330200	06330100
Capacity	30kg	60kg	150kg
Resolution	1g resolution up to 3kg, and 10g resolution for greater than 3kg		
Dimensions	330(W) x 509(D) x 84(H) mm		
Pan Size	330mm x 330mm		
Power Supply	AC Adaptor TB-S200A (included) or 4 x D batteries (not included)		

Accessories	Part Number	Price (ex GST)
OP-03 RS232C interface	06330101	\$125

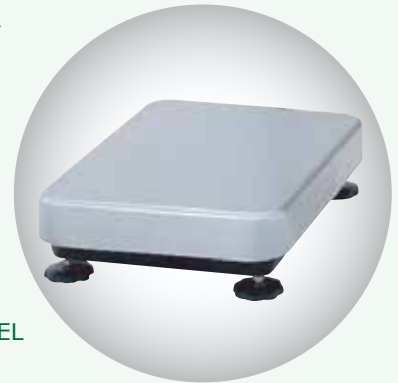

**SB IP65 PAN**  
PAINTED MILD STEEL

- Cast aluminium powder coated
- Can be connected to any of the A&D digital indicators
- Trade approved by NMI Australia
- Stainless steel pan
- Enclosed Aluminium loadcell for IP-65 protection
- Built to withstand the rigours of industrial usage

Specifications	SB-15K10-D	SB-60K11-D	SB-100K12-D	SB-200K12-D
Price (ex GST)	\$600	\$660	\$710	\$710
Part Number	03132203D	03132303D	03132403D	03132503D
Capacity	15kg	60kg	100kg	220kg
Pan Size	250mm x 250mm	330mm x 424mm	390mm x 530mm	

\*NMI Versions also require trade verification - fees apply

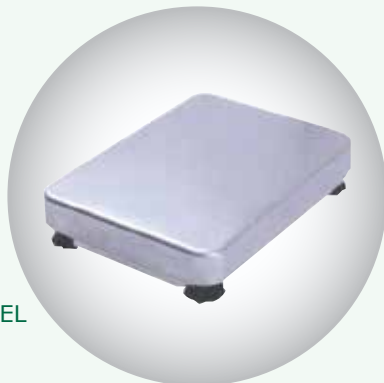

**SC IP68**  
STAINLESS STEEL

- Stainless Steel baseworks with IP-68 rating
- Can be used with any of A&D's digital indicators
- Epoxy coated Aluminium loadcell
- Built to withstand the rigours of industrial usage

Specifications	SC-30BM	SC-60BL	SC-150BL
Price (ex GST)	\$830	\$940	\$1,060
Part Number	06160850	06160650	06160750
Capacity	30kg	60kg	150kg
Pan Size	300mm x 380mm	390mm x 530mm	390mm x 530mm

\*NMI Versions also require trade verification - fees apply

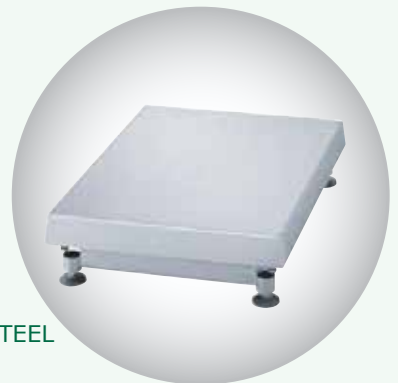

**SW IP69K**  
STAINLESS STEEL

- Premium resistance to hostile environments
- Can be connected to any of the A&D digital indicators
- Built to withstand the rigours of industrial usage
- Stainless Steel loadcell

Specifications	SW-60KBM	SW-150KBM	SW-60KBL	SW-150KBL
Price (ex GST)	\$1,750	\$1,750	\$2,340	\$2,340
Part Number	06162200	06162300	06162400	06162500
Capacity	60kg	150kg	60kg	150kg
Pan Size	300mm x 380mm		390mm x 530mm	

\*NMI Versions also require trade verification - fees apply



# AD-300 & AD-600 Series

## Accurate Platform Scales



AD-300 & AD-600  
Platform Scales

Trade Approval  
NMI #6/9C/250A  
(AD300KA4 only)



Option



- Large capacity stainless steel platform
- Low profile design allows for easy access
- Powered by TB-S200A adaptor
- Wall mount configuration available  
Cable length is approx. 4m

Specifications	AD-300KA4	AD-600KA4
Price (ex GST)	<b>\$3,180</b>	<b>\$3,180</b>
Part Number	<b>03113600</b>	<b>03113500</b>
Calibration	External	External
Capacity	300kg	600kg
Resolution	0.1kg	0.1kg
Pan Size	600mm x 700mm	600mm x 700mm
Product NMI	Trade Approved	Not Approved

\*NMI Versions also require trade verification - fees apply

Options	Part Number	Price (ex GST)
AD-300KA4 with wall mount (without column)	03113600-W	\$3,180
AD-600KA4 with wall mount (without column)	03113500-W	\$3,180

# SD-200

## Warehouse Trolley Scales



- High Weighing capacity (200kg maximum)
- Fully Portable and easy to maneuver
- Sturdy construction and high stability
- Battery operated indicator

Specifications	SD-200 
Price (ex GST)	<b>\$1,870</b>
Part Number	<b>06163000</b>
Capacity	200kg
Resolution	0.5kg
Dimensions	900(W) x 600(D) x 900(H) mm
Platform Size	900mm x 600mm
Power Supply	6 x C size batteries included

 ex Japan



# ELP-700 / ELP-1200 Series

## Low Profile Pallet Scales for Dry Areas



Trade Approval  
NMI #6/9C/220B

### Indicator



NMI #5778



### Option



**ELP-700**  
700mm x 700mm platform



AD-4406A Indicator  
Combo option  
(bracket is not  
included as standard)



**ELP-1200**  
1200kg Weighing in dry areas



Feet  
option  
(swivel)

- Low profile design allows for easy access
- Painted steel platform ideal for dry areas
- Not suitable for pit mount
- Loadcell cable 5m
- Ramp options available

**Supplied uncalibrated - Calibration fees apply**

Specifications	ELP-700 Base Only	ELP-1200 Base Only
Price (ex GST)	<b>\$840</b>	<b>\$1,190</b>
Part Number	<b>03010200 BASE ONLY (PAINTED)</b>	<b>03010105 BASE ONLY (PAINTED)</b>
Capacity	600kg x 0.2kg or 300kg x 0.1kg	1200kg x 0.5kg
Construction	Mild Steel	Mild Steel
Material Finish	Painted	Painted
Platform Dims	700mm x 700mm	1200mm x 1200mm
Platform Fixing	Welded to base frame	Welded to base frame
Weight of scale	Approx. 49kg	Approx. 95kg
Load cells	4 x ADA-K500 load cells	4 x ADALC1-T1 shear beam
Application Area	Lighter Capacity in Dry Areas	
Application	Not suitable for pit mount	
Base Height	100mm to 120mm	
Corner Adjustment	Side mounted junction box	

\*NMI Versions also require trade verification - fees apply  
Pallet Scales can be set to 600kg x 0.2kg

Accessories	Part Number	Price (exGST)
ELP-1200 & AD4406A (Trade Approved) Combo	03010105 & 06138600	\$1,550
ELP-700 & AD4406A (Trade Approved) Combo	03010200 & 06138600	\$1,210
Levelling leg (old style) Dia = 35mm	MC07019.000	\$50
Levelling leg (swivel style, Ni Plated) Dia = 60mm	MC07034.000	\$50
OP-12 Stainless steel wall bracket	03176100	\$70
Cast loadcell 7 pin plug for indicator (has holes)	EAJM-NJC207-PF	\$70
Loadcell cable with 7 pin plug	EMKO-11915	\$90
Painted ramp to suit ELP-1200 (900mm or 1200mm)	03010106	\$1,290

\*NMI Versions also require trade verification - fees apply

# A&D 3000 Series

## Low Profile Pallet Scales



A&D-3000 Pallet Scale  
3 Tonnes Weighing  
ideal for dry areas only.



AD-4406A Indicator  
Combo option  
(bracket is not  
included as standard)



Feet  
option  
(swivel)

### Supplied uncalibrated

- Approved for Trade Use\*
- High Strength in Dry Areas
- Loadcell cable 5m
- Ramp options available
- Low profile design allows for easy access

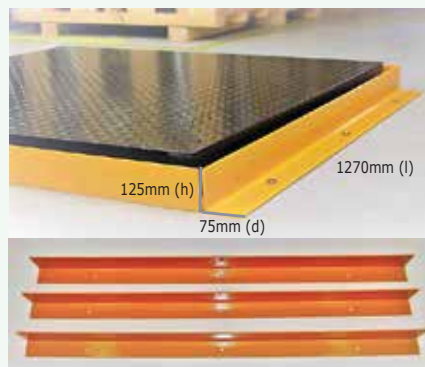

Forklift barrier  
option sold  
individually.

Trade Approval  
NMI #6/9C/220B



#### Indicator

NMI #5778



#### Option



Specifications	A&D-3000 Base Only	A&D-3000 Base Only	A&D-3000 Drop Centre with Ramp Base
Price (ex GST)	\$2,195	\$4,260	\$4,260
Part Number	03010102	03010206	03010205
Platform Dims	1200mm x 1200mm	1500mm x 1500mm	1200mm x 1200mm with drop centre
Capacity	3T x 1kg or 1.5T x 0.5kg*	3T x 1kg or 1.5T x 0.5kg*	1.2T x 0.5kg
Material Finish	Painted		
Construction	Mild Steel		
Platform Fixing	Welded to base frame		
Weight of scale	Approx. 110kg		
Load cells	ADALC1-T1		
Application Area	High Strength in Dry Areas		
Application	Not suitable for pit mount		
Base Height	140mm to 155mm		
Corner Adjustment	In-line cable summing unit		

NMI Versions also require trade verification - fees apply

\*Trade Approved Setup – Single Range 1500kg x 0.5kg or 3000kg x 1 kg and dual range 1500kg/3000kg x 0.5/1kg (other trade and non-trade setups available)

Accessories	Part Number	Price (ex GST)
A&D-3000 (1200x1200) & AD4406A (Trade Approved) Combo	03010102 & 06138600	\$2,630
A&D-3000 (1500x1500) & AD4406A (Trade Approved) Combo	03010206 & 06138600	\$4,710
A&D-3000 (drop centre with ramp) & AD4406A (Trade) Combo	03010205 & 06138600	\$4,710
Painted ramp to suit standard A&D3000 (1200mm x 900mm)	03010104	\$1,260 NETT
Forklift barrier option (sold individually)	03014002	\$230
Levelling leg (old style) Dia = 35mm	MC07019.000	\$50
Levelling leg (swivel style) Dia = 65mm	MC07032.000	\$50
A&D3000 summing unit 5m cable (no plate)	EMKO-11910	\$140
OP-12 Stainless steel wall bracket	03176100	\$70
Cast loadcell 7 pin plug for indicator (has holes)	EAJM-NJC207-PF	\$70
Cast loadcell 7 pin socket for basework (has pins)	EAJM-NJC207-RM	\$70

\*NMI Versions also require trade verification - fees apply



# ELP-3000 Series

## Low Profile Pallet Scales for Wet & Dry Areas

### Pallet Scales



Trade Approval  
NMI #6/9C/220B



### Indicators



(AD-4407)



AD4406A  
#5778  
AD4407  
#5451



(AD-4407)



### Option



(AD-4406A)

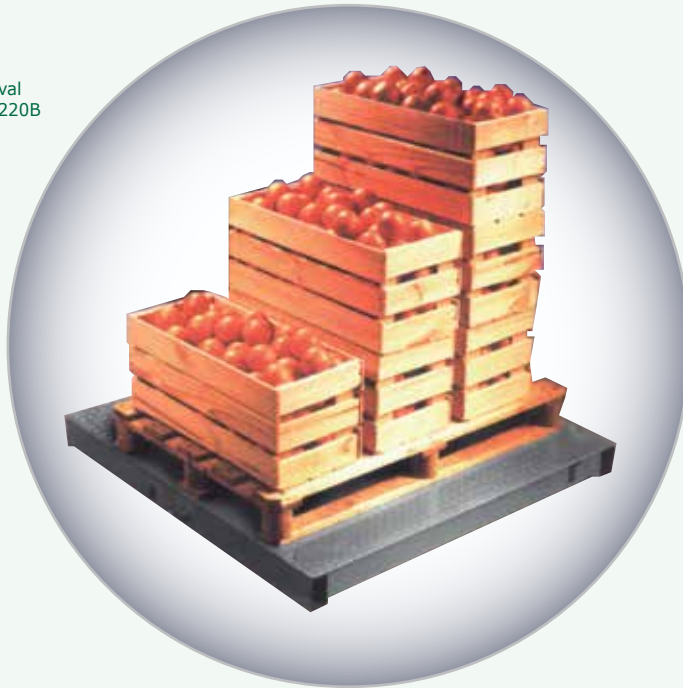

AD-4407 or AD-4406A  
Indicator Combo option\*



Bracket is not included as standard with the AD-4406A

**Supplied Uncalibrated**

**Non standard sizes and capacities available. Please inquire**

- Full SUS430 Stainless Steel Loadcells
- Low profile design allows for easy access
- Suitable for use with all A&D indicators
- Ramp options available
- Loadcell cable 5m



Feet option (Swivel)

### Specifications

### ELP-3000 Base Only

Price (ex GST)	<b>\$2,995</b>
Part Number	<b>03010201 BASE ONLY (GALVANISED, 3T capacity)</b>
Price (ex GST)	<b>\$7,020</b>
Part Number	<b>03010203 BASE ONLY (SUS304 Stainless Steel, Max. 2T capacity)</b>
Capacity	3000kg x 1kg or 1500kg x 0.5kg*
Construction	Mild Steel
Material Finish	Galvanised
Platform Dims	1200mm x 1200mm
Platform Fixing	Screwed to base frame
Weight of scale	Approx. 115kg
Load cells	4 x LCM13-T001 SUS430 shear beam
Application area	Wet and Dry Areas
Application	Suitable for pit mount
Base Height	140mm to 155mm
Corner Adjustment	In-line cable summing unit

NMI Versions also require trade verification - fees apply

\*Trade Approved Setup – Single Range 1500kg x 0.5kg, or 3000kg x 1 kg and dual range 600kg x 0.2kg, 1500kg/3000kg x 0.5/1kg (other trade and non-trade setups available)

Accessories	Part Number	Price (exGST)
ELP-3000 & AD4406A (Trade Approved, Galvanised) Combo	03010201 & 06138600	\$3,345
ELP-3000 & AD4407 (Trade Approved, Galvanised) Combo	03010201 & 06138700	\$3,665
Stainless steel ramp to suit ELP-3000 (900mm or 1200mm)	03010108	\$3,050
Galvanised ramp to suit ELP-3000 (900mm or 1200mm)	03010107	\$1,980
Painted ramp to suit ELP-3000 (900mm or 1200mm)	03010106	\$1,290
Forklift barrier option (sold individually 125 x 75 mm)	03014002	\$230
Levelling leg (swivel style) Dia = 65mm	MC07032.000	\$50
ELP3000 summing unit 5m cable with cover plate	EMKO-11909	\$190
OP-12 Stainless Steel wall bracket for AD-4406	03176100	\$70
In ground mounting plates	03010202	\$110
In ground pit surround 1200mm x 1200mm	03011200	\$460
Cast loadcell 7 pin plug for indicator (has holes)	EAJM-NJC207-PF	\$70
Cast loadcell 7 pin socket for basework (has pins)	EAJM-NJC207-RM	\$70

\*NMI Versions also require trade verification - fees apply

**\*All combinations supplied uncalibrated  
Bracket is not included with AD-4406**



# OHT Series Overhead Track Scales



Trade Approval  
NMI #6/18/17C



OHT combinations are supplied uncalibrated

AD-4407 Indicator Combo option  
(bracket is included as standard)

**Ask us if you require  
alternate capacities and rail lengths!**

- Quality galvanised finish
- Also available 300kg x 0.1kg NMI approved (longer leadtime for this)
- Waterproof track scale suitable for wet environments
- Choice of indicators to suit various applications
- Choice of optional bracket lengths. Standard are 200mm
- Weigh rail thickness: 13mm
- Can ONLY be Trade Verified AFTER installation
- Centre and End load compensation feature for accurate weighing

Specifications	OHT 300mm	OHT 600mm	OHT 1200mm
<b>Price (ex GST)</b>	<b>\$3,170</b>	<b>\$3,170</b>	<b>\$3,170</b>
<b>Part Number</b>	<b>03020101</b>	<b>03020102</b>	<b>03020103</b>
Capacity	600kg	600kg	600kg
Resolution	0.2kg	0.2kg	0.2kg
Weigh rail	300mm	600mm	1200mm

\*NMI Versions also require trade verification - fees apply

**IMPORTANT NOTE:** OHT pre-despatch set up cost is \$170.00

Accessories	Part Number	Price (ex GST)
OHT 300mm rail & AD4407 combo	03020101 & 06138700	\$3,710
OHT 600mm rail & AD4407 combo	03020102 & 06138700	\$3,710
OHT 1200mm rail & AD4407 combo	03020103 & 06138700	\$3,710
OHT OP-01 125mm brackets (pair)	03022001	\$370
OHT OP-02 250mm brackets (pair)	03022002	\$370



# AD-4401A / AD-4402 / AD-4404

## AD Batching Indicators



- High performance weighing / batching indicator
- High speed A/D convertor - 100 per second, High display resolution up to 1 in 16000
- High Internal A/D resolution of up to 1,000,000 counts
- Monitor & Control weighing & Batching using displayed or internal counts
- Fuzzy logic or standard Automatic Free Fall Compensation for consistent results
- Automatic weight or count accumulation
- Up to eight 350Ω load cells can be connected in parallel.
- **NMI Trade Approval pending**

<b>Specifications</b>	<b>AD-4401A</b>
<b>Price (ex GST)</b>	<b>\$2,050</b>
<b>Part Number</b>	<b>06138308</b>
<b>Power</b>	<b>AC Mains</b>
<b>Dimensions</b>	144(W) x 197(D) x 72(H) mm

\*NMI Versions also require trade verification - fees apply



**AD-4401A INDICATOR**

Accessories*	Part Number	Price (ex GST)
AD-4401A OP-01 BCD output	06138311	\$500
AD-4401A OP-03 RS422/RS485 interface	06138313	\$500
AD-4401A OP-04 RS232C + current loop serial	06138314	\$500
AD-4401A OP-07 analog output	06138317	\$650
AD-4401A OP-23 Ethernet	06138323	\$650

\*Please note: AD-4401A accessories do not fit the superseded AD-4401.



- Multi function from batch weighing to field bus networking applications
- Main display has 7-digit VFD with 18mm high characters
- Sub display has 108 x 5mm high characters to show values and comments
- Pre-programmed with multiple sequences and functions for filling machines and simple mixing
- Up to eight 350Ω load cells can be connected in parallel.
- Stores 100 data for raw materials and 100 data for recipes
- **OP-21 DeviceNet Interface is no longer available**

<b>Specifications</b>	<b>AD-4402</b>
<b>Price (ex GST)</b>	<b>\$3,240</b>
<b>Part Number</b>	<b>06138400</b>
<b>Power</b>	<b>AC Mains</b>
<b>Dimensions</b>	192(W) x 135(D) x 96(H) mm

\*NMI Versions also require trade verification - fees apply



**AD-4402 INDICATOR**

Accessories	Part Number	Price (ex GST)
OP-01 Parallel BCD Output	06138401	\$800
OP-02 Relay Output	06138402	\$800
OP-03 RS422/RS485 interface	06138403	\$800
OP-04 RS232C + current loop serial	06138404	\$800
OP-05 Parallel I/O	06138405	\$800
OP-07 Analogue Output	06138407	\$900
OP-20 CC-Link Interface	06138420	\$1,360
OP-22 PROFIBUS interface	06138422	\$2,410



- High performance advanced checkweighing indicator
- Up to 100 sets of target (OK weight), Hi, Lo and tare can be stored by code number
- Twin displays show weight and operational details
- Sealed keys keep out dust in industrial environments IP65 grade
- User programmable check-weighing modes to meet many specific requirements
- Up to eight 350Ω load cells can be connected in parallel.

<b>Specifications</b>	<b>AD-4404</b>
<b>Price (ex GST)</b>	<b>\$3,240</b>
<b>Part Number</b>	<b>06139200</b>
<b>Power</b>	<b>AC Mains</b>
<b>Dimensions</b>	192(W) x 135(D) x 96(H) mm

\*NMI Versions also require trade verification - fees apply



**AD-4404 INDICATOR**

Accessories	Part Number	Price (ex GST)
OP-21 DeviceNet Interface	06139221	\$1,880

Additional AD-4404 Options: See AD-4402 Options

# AD-4405 / AD-4406A / AD-4407 AD Indicators



- Ten keys for preset tare and units weighing setting etc
- Accumulative data can be stored into memory automatically or manually
- Comparator Function Upper/Lower, HiHi/Hi/OK/Lo/Lolo & comparison
- 2 weighing ranges selectable
- Up to four 350Ω load cells can be connected in parallel
- Optional Dot Matrix Printer
- RS-232 Interface comes as standard

Specifications	AD-4405
Price (ex GST)	\$1,230
Part Number	06138500
Power	AC Mains
Dimensions	275(W) x 159(D) x 111(H) mm

\*NMI Versions also require trade verification - fees apply



**AD-4405  
INDICATOR**

Accessories	Part Number	Price (ex GST)
OP-03 RS422/RS485 interface*	06138503	\$450
OP-05 RS232C + relay output*	06138505	\$450
OP-06 Dot Matrix Printer	06138506	\$830
OP-07 4-20mA Analog output	06138507	\$450

\*Only one of these can be installed/fitted

NMI #S451



- Powered by TB-S200A adaptor or alkaline C type battery  
Battery life 180 hours (LC 350ohms x 1); battery life 70 hours (LC 350ohms x 4)
- Accumulative data can be stored into memory automatically or manually
- Automatic batching and customer programming capability
- Up to four 350Ω load cells connected in parallel
- F1, F2 selectable function keys
- Optional stand/bracket available

Specifications	AD-4406A
Price (ex GST)	\$520
Part Number	06138600
Power	TB-S200A (included) C size battery (not included)
Dimensions	192(W) x 87(D) x 96(H) mm

\*NMI Versions also require trade verification - fees apply



(bracket is not included as standard)

**AD-4406A  
INDICATOR**

Accessories	Part Number	Price (ex GST)
OP-03 RS422/RS485*	06138603	\$490
OP-04 programmable RS232C*	06138604	\$180
OP-05 RS232 & relay output*	06138605	\$490
OP-07 4-20mA analog output*	06138607	\$540
OP-12 stainless steel bracket (wall/desk)	03176100	\$70

\*Only one of these can be installed/fitted

NMI #S778

IN PANEL



- Ideal for dust and waterproof weighing applications with IP65 grading
- NMI Trade approved scale
- Automatic batching and customer programming capability
- Counting function
- Up to eight 350Ω load cells can be connected in parallel
- RS-232 Interface comes as standard
- Bracket comes as standard

Specifications	AD-4407
Price (ex GST)	\$1,080
Part Number	06138700
Power	AC Mains
Dimensions	199(W) x 80(D) x 206(H) mm

\*NMI Versions also require trade verification - fees apply



**AD-4407  
INDICATOR**

Accessories	Part Number	Price (ex GST)
OP-03 RS422/RS485*	06138703	\$540
OP-05 RS232 & relay output*	06138705	\$540
OP-07 4-20mA analog output*	06138707	\$540

\*Only one of these can be installed/fitted

NMI #S451





# AD-4408

## AD Process Indicators

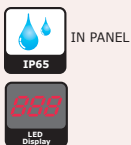

- Various types of field network (fieldbus) modules can be installed
- High-performance digital filtering that eliminates the effects of strong vibration
- Compact, lightweight body makes it ideal for mounting into a control panel
- Dust and waterproof display (when mounted into a panel)
- Up to eight 350Ω load cells can be connected in parallel
- Highly tolerant against electromagnetic noise



AD-4408

<b>Specifications</b>	<b>AD-4408*</b>
<b>Price (ex GST)</b>	<b>\$2,160</b>
<b>Part Number</b>	<b>06148000</b>
<b>Power</b>	<b>AC Mains</b>
<b>Dimensions</b>	144(W) x 135(D) x 72(H) mm

\*Anybus option available: check brochure for details



# AD-4410

## AD Process Indicators



- Powerful vibration-cancelling function (High Performance Digital Filter)
- High speed sampling (100 times/second)/high accuracy
- Circuits equipped with powerful noise reduction
- Accurate linear correction function using high-order equations
- Up to eight 350Ω load cells can be connected in parallel
- Average holding function
- Comes equipped with Modbus-RTU



AD-4410

<b>Specifications</b>	<b>AD-4410*</b>
<b>Price (ex GST)</b>	<b>\$2,160</b>
<b>Part Number</b>	<b>06134500</b>
<b>Power</b>	<b>AC Mains</b>
<b>Dimensions</b>	144(W) x 110(D) x 72(H) mm

\*Anybus option available: check brochure for details



# AD-4329

## Basic Weighing Indicators

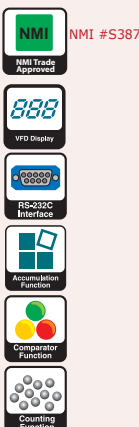

- The AD-4329 has triple range for scales with multiple weighing intervals
- The AD-4329 comes with RS-232 relay output as standard
- Check weighing mode (3 levels) to compare weighing data
- Set point comparison for batching applications
- Up to eight 350Ω load cells can be connected in parallel
- Accumulated data can be manually or automatically stored in the memory

AD-4329

<b>Specifications</b>	<b>AD-4329</b>
<b>Price (ex GST)</b>	<b>\$970</b>
<b>Part Number</b>	<b>06139100</b>
<b>Power</b>	<b>AC Mains</b>
<b>Dimensions</b>	192(W) x 165(D) x 96(H) mm

\*NMI Versions also require trade verification - fees apply



Accessories	Part Number	Price (ex GST)
AD-4329 Comparator relay output	06139002	\$410



# AD4430A / AD4430B / AD4430R

## DIN Rail Indicators



- Powerful vibration-cancelling filter HPDF (High Performance Digital Filter)
- Dual HPDF
- Flow rate output
- Control I/O (6 inputs, 8 outputs) as standard
- USB interface to import/export function settings
- Averaging hold, peak hold and comparator functions
- DIN rail mounting type to install into control box
- Up to four 350Ω load cells can be connected in parallel

Specifications	AD-4430A
Price (ex GST)	<b>\$1,080</b>
Part Number	<b>06149100</b>
Power	24V DC
Dimensions	36(W) x 110(D) x 101(H) mm



**AD-4430A INDICATOR**  
Analog output 4 to 20mA

- DIN rail mounted type ideal for insertion into control board
- Powerful vibration-cancelling function (High Performance Digital Filter)
- Control I/O (6 inputs, 1 outputs) as standard
- High speed sampling (1000 times per second) - High accuracy
- BCD input/output a standard feature (up to 1000 times/sec high speed output)
- Equipped with powerful noise suppression circuit
- Accurate linear correction function using high-order equations
- Up to four 350Ω load cells can be connected in parallel

Specifications	AD-4430B
Price (ex GST)	<b>\$1,080</b>
Part Number	<b>06149000</b>
Power	24V DC
Dimensions	36(W) x 110(D) x 101(H) mm



**AD-4430B INDICATOR**  
BCD output

- Powerful vibration-cancelling filter (High Performance Digital Filter)
- Dual HPDF
- Dual flow rate output
- Sequential filling/dispensing measurement capability
- Internal setpoint control
- Active free fall compensation
- I/O points (6 inputs, 8 outputs) as standard
- Remote I/O connectivity for PLC input and output
- USB interface to import/export function settings
- Averaging hold, peak hold and comparator functions
- DIN rail mounting type to install into control box
- Up to four 350Ω load cells can be connected in parallel

Specifications	AD-4430R
Price (ex GST)	<b>\$1,080</b>
Part Number	<b>06149200</b>
Power	24V DC
Dimensions	36(W) x 110(D) x 101(H) mm



**AD-4430R INDICATOR**  
Modbus RTU (RS-485)

Accessories	Part Number	Price (ex GST)
Micro B USB A Cable	06138542	\$POA
MDR 20 Cable (connector to bare wires) 1m	06138543	\$POA
MDR 20 Cable (connector to connector) 1m	06138544	\$POA



# AD-4530

## Digital Indicator for Strain Gauge Sensors

- Digital Zero (DZ) stores zero data at any measurement point. This function can also be used to tare weight.
- Measurement can simply be restarted when it was interrupted by a loss of power.
- Power on zero function adjusts to zero when the power is turned on.
- Digital filter provides stable measurement results.
- Digital span calibration. Easy calibration just by inputting the rated output of a sensor. No need to use a mass.
- Unit characters - Up to five alphanumeric characters can be added to serial output.
- Up to three 350Ω load cells can be connected in parallel
- Comparator function displays and outputs HI, OK and LO according to upper and lower limit settings. Hysteresis width and time can be set to prevent chattering on the output terminal. This reduces load on the relay circuit.
- Various data output (optional). Necessary data can be easily obtained using optional comparator relay output, serial output (RS-485/RS-232C), D/A voltage output and D/A current output.



Option



Specifications	AD-4530
Price (ex GST)	\$480
Part Number	06138540
Power	AC Mains
Dimensions	96(W) x 48(H) x 120(D) mm



**AD-4530**

Accessories	Part Number	Price (ex GST)
AD-4530/31B Relay Output	06138532	\$90
AD-4530/31B RS485	06138533	\$160
AD-4530/31B RS-232C	06138534	\$80
AD-4530/31B 4-20mA Analog Output	06138537	\$110
AD-4530/31B Relay Output + RS-485 + 4-20mA Analog O/P	06138535	\$170
AD-4530/31B Relay Output + RS-232C + 4-20mA Analog O/P	06138536	\$170



# AD-4531B

## AD Indicators

- Suitable for load, pressure, torque or tension measurement plus more
- Digital span calibration possible without using an actual load
- Zero correction value can be backed up
- Various output options available
- Performs A/D conversion at 100 times per second
- Up to three 350Ω load cells can be connected in parallel



Option



Specifications	AD-4531B
Price (ex GST)	\$690
Part Number	06138531
Power	AC Mains
Dimensions	96(W) x 128(D) x 48(H) mm

**Extra discounts  
for BULK orders!**



**AD-4531B**  
for Strain Gauge Sensors

Accessories	Part Number	Price (ex GST)
AD-4530/31B Relay Output	06138532	\$90
AD-4530/31B RS485	06138533	\$160
AD-4530/31B RS-232C	06138534	\$80
AD-4530/31B 4-20mA Analog Output	06138537	\$110
AD-4530/31B Relay Output + RS-485 + 4-20mA Analog O/P	06138535	\$170
AD-4530/31B Relay Output + RS-232C + 4-20mA Analog O/P	06138536	\$170

# AD-4413-CW

## IP65 Colour LCD Touch Panel



Our high functionality AD-4413-CW checkweighing touch panel indicator has been specially designed to weigh, classify and segregate products based on weight.



Specifications	AD4413-CW
Price (ex GST)	\$5,150
Part Number	03057030
Power	AC Mains
IP Rating	IP65 when mounted in panel
Dimensions	224(W) x 208(D) x 185(H) mm

Accessories	Part Number	Price (ex GST)
AD4413 OP-02 Relay Output	03057040	\$850
AD4413 OP-05 Parallel Output	03057050	\$950
AD4413 OP-07 Analogue Output	03057060	\$850
AD4413 OP-10 Panel Mount Kit	03057010	\$350
AD4413 OP-11 Stand attachment kit	03057070	\$200
AD4413 OP-17 Analogue Output Module	03057080	\$400

# AD-4532B

## AD Process Indicators



- High Speed Weighing- 2000 updates per second
- Wide Variety of Standard Data I/O- Analog Amplifier Voltage Output (+/-10v), D/A Analog Voltage Output (+/-10v), Comparator Output and a Modbus RTU I/O
- 5 Level Comparator- Multi level settings for a multi level test procedure
- Displayed Upper and Lower Setting-Immediate recall of test parameters
- 4 Different Hold Functions-Select from Peak, Bottom, Sample, Bipolar Hold
- Up to four 350Ω load cells can be connected in parallel

Specifications	AD-4532B
Price (ex GST)	\$1,810
Part Number	06230700
Power	AC Mains
Dimensions	96(W) x 168(D) x 96(H) mm



**AD-4532B INDICATOR**

IN PANEL



Accessories	Part Number	Price (ex GST)
OP-01 BCD Output (40 pin FCN connector)	06230504	\$360
OP-04 RS232C (D-Sub 9 pin)	06230505	\$360
OP-07 D/A Analog Volt/Current Output (+/-10V)	06230503	\$480
OP-08 Ethernet interface (RJ-45)	06230506	\$840

# AD-4541-V/I

## Ultra Slim Analog Signal Conditioner



- Ultra-slim, lightweight and easy-to-install
- Up to four 350Ω load cells can be connected in parallel
- Calibration can be performed with the ZERO / SPAN volume controls or the CAL switch
- Wide-range zero adjust. ( $\pm 1.6\text{mV/V}$ ) / span adjust. ( $0.4\sim 3.2\text{mV/V}$ ) for use with various bridge type sensors
- No crimping terminal is necessary because a spring clamp terminal block is used for easy wiring



**AD-4541-V/I SIGNAL CONDITIONERS**

Specifications	AD-4541-I	AD-4541-V
Price (ex GST)	\$610	\$610
Part Number	06134200	06134300
Output	4mA to 20mA	-2V to +2V
Power	24V DC	
Dimensions	45(W) x 122(D) x 24(H) mm	



# FSi-D / SW-D / SC-D

## Waterproof Indicators with Rapid Stabilisation

The FS-D, which comes with a desktop/wall-mount stand and a connector plug, can even be used with platform scales other than A&D's. The eight preset capacities range from 6 kg (15 lb) to 1,500 kg (3,500 lb) and the three resolutions from 1/3,000 to 1/12,000 (or 1/15,000) (NB: only one of each can be selected at a time). Up to four 350Ω load cells can be connected in parallel. Capacities are selectable from fixed range and maximum capacity is 1500kg.



Specifications	FSi-D DISPLAY
Price (ex GST)	<b>\$1,520</b>
Part Number	<b>06132500</b>
Power	AC Mains Rechargeable battery (included)
Bracket	Included
Dimensions	250(W) x 130(D) x 150(H) mm



**FSi-D IP65  
INDICATOR  
NON TRADE**

Accessories	Part Number	Price (ex GST)
OP-03 RS232 & relay output	03078001	\$290
OP-04 RS422 / 485 + relay output	03078002	\$350
Rechargeable battery (Approx. 80 hrs)	ECEB-6V	\$40

The SW display unit (SW-D) is as an IP69K indicator with touch sensitive capacitive keys to ensure permanent waterproofing in damp/wet environments. The SW indicator has 5 step comparator lights and can also be used with platform scales other than A&D's. Capacity and division can be freely set.



Specifications	SW-D DISPLAY
Price (ex GST)	<b>\$1,450</b>
Part Number	<b>06162100</b>
Power	AC Mains Rechargeable battery (included)
Bracket	Not Included
Dimensions	255(W) x 134(D) x 178(H) mm



**SW-D IP69K  
INDICATOR  
NON TRADE**

Accessories	Part Number	Price (ex GST)
OP-03 RS232C serial interface	06162001	\$400
OP-04 RS422 / 485 interface	06162002	\$400
OP-11 Bench/Wall bracket	06162004	\$240
Rechargeable battery (Approx. 90hrs)	ECEB-6V-YUASA	\$50

The SC display Indicator (SC-D) is as an IP68 completely sealed indicator to ensure permanent waterproofing in damp/wet environments. The SC indicator can be submersed in up to 1m of water for 24 hours. Capacity and divisions are: 3kg x 0.0005kg, 6kg x 0.001kg, 15kg x 0.002g, 30kg x 0.005g, 60kg x 0.01g, 150kg x 0.02g. Up to four 350Ω load cells can be connected in parallel. Capacities are selectable from fixed range and maximum capacity is 1500kg.



Specifications	SC-D DISPLAY
Price (ex GST)	<b>\$540</b>
Part Number	<b>06163800</b>
Power	6 x D size batteries
Bracket	Not Included
Dimensions	250(W) x 178(D) x 170(H) mm



SC-D bracket  
option



**SC IP68  
INDICATOR  
NON TRADE**

Accessories	Part Number	Price (ex GST)
SCSE OP-02 Quick USB Interface (cable not included)	06160401	\$240
SCSE OP-03 RS-232C + Comparator relay output	06160402	\$350
SC-D OP-04 Wall/Desk mounting bracket	06163810	\$100



# HC-i Series Precision Counting Scales

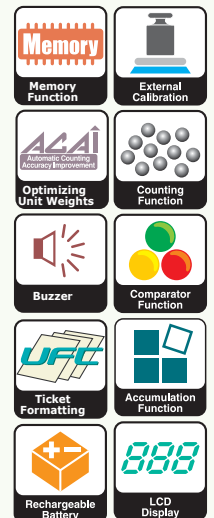

#### Options

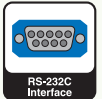

- Three methods to initialize unit weights: sample, memory, and keyboard input
- Large memory for 99 products incl. Tare, Unit weight and Comparator limits
- Navigation system with LEDs indicating active keys for easy and faster operation
- Comparator with HI (exceeding), OK, and LO (insufficient) results
- Accumulation function totals piece count into memory
- High internal resolution 1/600 000 or 1/750 000 & Ability to count small objects down to 0.005g
- Beeping function with frequency variation as you approach your preset target
- UFC: easy formatting of your RS-232C outputs and labels for printers
- Length of extension cable is 60cm

Specifications	HC-3Ki	HC-6Ki	HC-15Ki	HC-30Ki
Price (ex GST)	\$540	\$540	\$540	\$540
Part Number	06012600	06012700	06012800	06012900
Calibration	External	External	External	External
Capacity	3kg	6kg	15kg	30kg
Resolution	0.5g	1g	2g	5g
Min Piece Weight (fine)	0.005g	0.01g	0.02g	0.05g
Dimensions	315(W) x 331(D) x 126(H) mm			
Pan Size	300mm x 210mm			
Power Supply	AC Adaptor TB-S200A or rechargeable battery included			

Accessories	Part Number	Price (ex GST)
Serial Cable DIN Male to DB9 Female	03000002	\$60
HCi OP-03 RS232C Serial Data Interface	06012003	\$200
HCi OP-04 RS232C + Relay Output	06012004	\$260
HCi OP-08 Extension Cable (2m)	06012008	\$120
Rechargeable Battery (Approx. 80hrs)	ECEB-6V	\$40



# FC-i / FC-Si Series

## High Performance Counting Scales



Simple operation and easy to read Vacuum Fluorescent Display



FC-5000i

### Options



- High internal resolution: 1/10 000 000(FC-Si) and 1/1 000 000(FC-i)
- Up to three RS-232C ports
- FC-Si models come with SHS sensor
- Four methods to initialize the unit weight: sample, memory, keyboard input, and bar code reading
- Automatic counting accuracy improvement (ACAI)
- Comparator with HI (exceeding), OK, and LO (insufficient) results
- Accumulation function totals piece count into memory
- Remote platform option offers bulk counting
- Large memory for up to 500 IDs (ID, unit weight, tare, comparator limit)
- Navigation system with LEDs indicating active keys for faster operation



FC-Si with optional traffic light and optional comparator relay interface

Specifications	FC-500Si	FC-5000Si	FC-5000i	FC-10Ki	FC-20Ki	FC-50Ki
Price (ex GST)	\$2,960	\$2,960	\$2,480	\$2,480	\$2,480	\$2,480
Part Number	06020100	06020200	06020400	06020500	06020600	06020700
Calibration	External	External	External	External	External	External
Capacity	500g	5kg	5kg	10kg	20kg	50kg
Resolution	0.02g	0.2g	0.5g	1g	2g	5g
Min Piece Weight (fine)	0.00005g	0.0005g	0.005g	0.01g	0.02g	0.05g
Dimensions	330(W) x 462(D) x 106(H)mm		330(W) x 462(D) x 117(H) mm			
Pan Size	128x128mm	165x165mm	300mm x 280mm			
Power Supply	AC Adaptor TB-S139 (included)					

ex Japan

Accessories	Part Number	Price (ex GST)
Serial Cable DB9 Female to DB9 Female	03000007	\$60
FCi OP-01 Barcode Reader	06020105	\$580
FCi OP-02 NiMH Battery Pack (Approx. 10 hrs)	06020104	\$920
FCi OP-03 Dual Channel RS232C	06020101	\$650
FCi OP-04 RS232C & Comp/Relay Output	06020102	\$650
FCi OP-05 Remote Scale Connector	06020103	\$460





# AND

A&D Inspection



*Avoid costly product recalls. Investing in Inspection Systems pays off.*



# Custom Inspection Systems

Heavy Duty and Customised Solutions



- **Custom-made size and capacity 5-500kg**
- Medium Speed - Maximum 60p/min
- Full colour touch screen LCD
- Robust Stainless Steel Design - IP65 available
- Designed and Manufactured in Australia
- Designed to meet the requirement of HACCP
- Easy cleaning and maintenance
- A&D Japan's controls and DSP technology
- Ethernet and Modbus communication
- Up to 1000 product IDs with images
- Programmable digital I/O
- Various custom solutions available

*Please Contact A&D for full specs and options*

## EZI-CHECK

Dynamic and Gravity Rollers

Drawing showing column option



Dynamic Roller



Gravity Roller

**AUSSIE  
MADE**

Specifications	Dynamic Roller (AUTO)	Gravity Roller (BASIC)
Price (ex GST)	<b>\$10,560</b>	<b>\$5,500</b>
Part Number	<b>03051085</b>	<b>03051080</b>
Weighing Capacity	30kg / 60kg / 150kg	30kg / 60kg / 150kg
Resolution	0.01kg / 0.02kg / 0.05kg	0.01kg / 0.02kg / 0.05kg
Conveyor	Powered rollers with PLC control	Heavy duty steel gravity rollers
Dimensions	600 (L) x 450 (W) x 900 (H) mm	
Indicator	Water & dust proof FS-i indicator	
HI / GO / LO	Built in traffic lights	
PC Interface	Wired or wireless options available	

The EZI-Check Auto Dynamic Roller & Basic Gravity Roller scales are freestanding, roller weighing systems that can be incorporated into new or existing production lines allowing precise checking of cartons for missing or damaged products, providing peace of mind.

### Accessories\*

Accessories*	Part Number	Price (ex GST)
Column option to suit the EZI-Check Roller Systems	03051081	\$360



# AD-4991

## ProteX X-Ray Systems



# PROTEX

S E R I E S

**Bringing Innovation  
to Inspection!**

- Increased consumer protection
- Brand protection and recall prevention
- Food safety compliance
- Tungsten Shielding Curtain
- Advanced Algorithms  
Built for more than just containments, we also provide mass estimation, shape detection, and component verification
- Compact Design  
Our equipment is the smallest in class to allow for easy in-line integration with minimal reconfiguration of existing equipment
- Easy to Read Display  
A 15-inch color touchscreen provides users with a vibrant screen for viewing high-resolution imagery
- Streamlined Product Setup  
Minimal inputs from the user makes setup and changeover quick

Specifications	AD-4991-2510	AD-4991-2515	AD-4991-3530
X-Ray Output	100W (50kV_2mA)	150W (50kV_3mA)	300W (75kV_4mA)
Conveyor Speed	10 to 45m / min	10 to 70m / min	10 to 45m / min
Weight	About 90kg	About 105kg	About 135kg
Conveyor Width	250mm		350mm
System Length	800mm		800mm
Conveyor Height	720mm - 860mm		
Max. Capacity	5kg (dependent upon speed)		
IP Rating	IP66 water & dust proof		
No. of recorded items	1000 items (10 groups x 100 items)		
Connectivity	Serial and Ethernet Comms, and multiple digital I/O		
Beam Diagram			

Model	Part Number	Price (ex GST)
ProteX AD-4991-2510 X-Ray system 100W, max. 45m/min	03058000	POA
ProteX AD-4991-2515 X-Ray system 150W, max. 70m/min	03058100	POA
ProteX AD-4991-3530 X-Ray system 300W, max. 45m/min	03058200	POA
ProteX X-ray Test cards	Various	\$150

# AD-4961 600g / 2000g

## Intelligent Checkweighers



- Full colour touch screen LCD
- Up to 400 packs per minute
- Up to 1000 product IDs with images
  - Save data/graphs direct to USB memory sticks
  - A&D's original, automatic adjustment function enables easy product parameter settings or adjustments
  - High speed, Digital Signal Processing (DSP)
  - Dual range 2kg model. The checkweigher's weighing range and resolution can be selected from 500g x 0.01g or 2000g x 0.1g
  - Meets the requirements of hygienic food processing
  - Stainless steel frame construction meets IP65 requirements
  - Easy switch to another production batch with minimal downtime
- Full interaction via MODBUS ethernet comms

**Air Jet Rejector**  
(two air nozzles)  
Requires air compressor with Ø10mm air tube.  
Supply: 0.5Mpa, 2.6NL/time

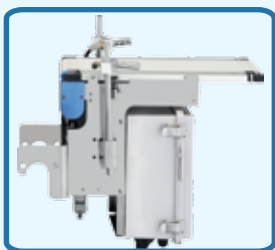

Flipper/Diverter Module



Drop Conveyor Module



Specifications	AD-4961-600	AD-4961-2KD	
Capacity	600g	500g	2000g
Resolution	0.01g	0.01g	0.1g
Repeatability 3σ	±0.08g	±0.08g	±0.18g
Max weighing speed	400 pcs / min	320 pcs / min	
Max belt speed	15-120m/min Urethane belt		
Belt Size	120(W) x 240(L) mm	200(W) x 350(L) mm	
Max. product dimensions	120mm(W), 22-200mm(L)	200mm (W), 30-300mm (L)	
Display	7inch colour LCD Touch Panel		
Recorded items	1000 items (10 groups x 100 items)		
Sealed USB port (IP-65)	USB 2.0 (memory & upload)		
Serial interface	RS232C or RS485 available		
Ethernet	10 Base-T/100Base-T Auto-MDIX		
Modbus	Modbus RTU & TCP available		
Dimensions	602(W)x660(L)x710-860(H)mm	660(W)x700(L)x710-860(H)mm	
Water/Dust resistance	IP65 Stainless Steel		
Power Supply	AC 100-240V With Emergency Function		

OP-11 Breeze Break option



**AD4413-CW**  
Indicator with 7" colour LCD touch panel



Model	Part Number	Price (ex GST)
<b>INTELLIGENT 600g x 0.01g Checkweigher (up to 400ppm)</b>	<b>03057000</b>	POA
600g dual air reject module	03057100	POA
<b>INTELLIGENT 2kg x 0.01g Checkweigher (up to 320ppm)</b>	<b>03055000</b>	POA
<b>AD-4413-CW Checkweighing Indicator only</b>	<b>03057030</b>	\$5,150
AD-4982-2035 Drop Conveyor module	03055020	POA
AD-4981-2057 2kg dual flipper rejector module	03055010	POA
AD-4984-2046 2kg dual air rejector module	03057200	POA
OP-20 leg extension feet set (for >850mm lines; limit 1020mm)	03055082	\$250
OP-01 display column stand	03055070	\$550
Patlight tower light and mtg plate option	06138879	\$400 nett
OP-02 tower Lights	06138877	\$120 nett
OP-11 breeze break	03055074-A	\$950
OP-14 product guides (pair)	03055080	\$650
CW PLUS data capture and reporting software	06086017	\$4,000
WinCT Plus multi scale data capture & import utility (LAN/Serial)	Please enquire	POA

# AD-4961 6kg

## 6kg Capacity Checkweigher



6kg Checkweigher with optional stand display and push rejector

- The AD-4961-6K weighing capacity is 6000g x 0.1g
- Full colour 7 inch panel touch screen LCD display
- Save data/graphs direct to USB memory sticks
- High speed, Digital Signal Processing (DSP)
- Meets the requirements of hygienic food processing
- Stainless steel frame construction meets IP65 requirements
- Up to 145 packs per minute
  - Up to 1000 product IDs with images
  - "Flat pack" ease of transport and setup
- Easy switch to another production batch with minimal downtime
- Full interaction via MODBUS ethernet comms



Specifications	AD-4961-6K
Capacity	6000g
Resolution	0.1g
Repeatability 3σ	±1.5g
Max weighing speed	145 pieces / min
Max belt speed	15-80m/min Urethane belt
Belt Size	300(W) x 500(L) mm
Max. product dimensions	300mm (W), 80-450mm (L)
Display	7inch colour LCD Touch Panel
Recorded items	1000 items (10 groups x 100 items)
Sealed USB port (IP-65)	USB 2.0 (memory & upload)
Serial interface	RS232C or RS485 available
Ethernet	10 Base-T/100Base-T Auto-MDIX
Modbus	Modbus RTU & TCP available
CW Dimensions	736(W) x 1005(L) x 720-870(H) mm
Push Rejector Dims	945(W) x 502(L) x 850(H) mm
Water/Dust resistance	IP65 Stainless Steel
Power Supply	AC 100-240V with Emergency Function

Push Rejector

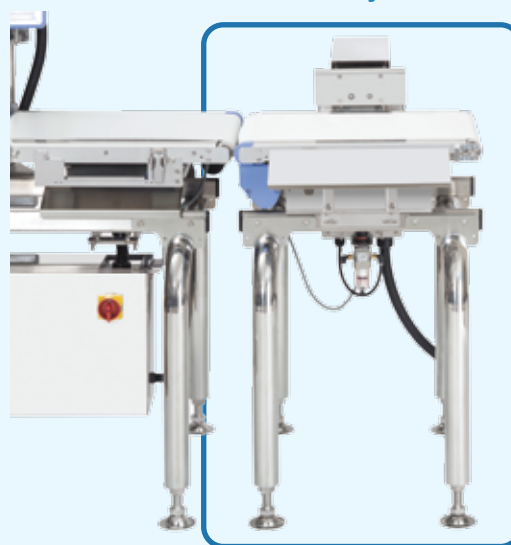

Model	Part Number	Price (ex GST)
<b>Checkweigher 6kg x 0.1g (up to 145ppm)</b>	<b>03055800</b>	POA
6kg push rejector module	03055900	POA
AD4981-2570 3kg single channel flipper	03055100	\$7,000
AD4981-2570-21 Extra arm	03055110	\$1,300
Product guides for 6kg	0305-149721G	\$420
Breeze break to suit 6kg module	03055075-E	\$950
Patlight Tower Lights & mtg plate option	06138879	\$400 nett
Motor Assembly 6kg (new)	7PA-4961-MO2	\$850
Motor Assembly 2kg (new)	1BCA4961-MO1	\$750
Drive Motor PCB control card for all models	PZ6229 V005	\$650
Motor Control PCB MD (Version 2)	7PZ-6644-CK	\$650

# AD-4971

## Metal Detector



**Customised sizes available**

Specifications	AD-4971
Max belt speed	10-60m/min Urethane belt
Belt Size	350mm: 250(W) x 800(L)   450mm: 350(W) x 800(L)
Display	7inch colour LCD Touch Panel
Conveyor length	800mm
Conveyor speed	10 - 60m/min
No. of recorded items	1000
Ethernet	10 Base-T/100Base-T Auto-MDIX
Modbus	Modbus RTU & TCP available
350 Dims (100mm)	625(W) x 800(L) x 1050~1200(H) mm
350 Dims (170mm)	625(W) x 800(L) x 1118~1268(H) mm
350 Dims (250mm)	625(W) x 800(L) x 1198~1348(H) mm
450 Dims (170mm)	625(W) x 800(L) x 1114~1264(H) mm
450 Dims (250mm)	625(W) x 800(L) x 1114~1264(H) mm
Water/Dust resistance	IP65 Stainless Steel
Power Supply	AC 100-240V With Emergency Function

\* Detection sensitivity will change depending on product and environmental conditions. Please prepare a φ4-7mm power cable.

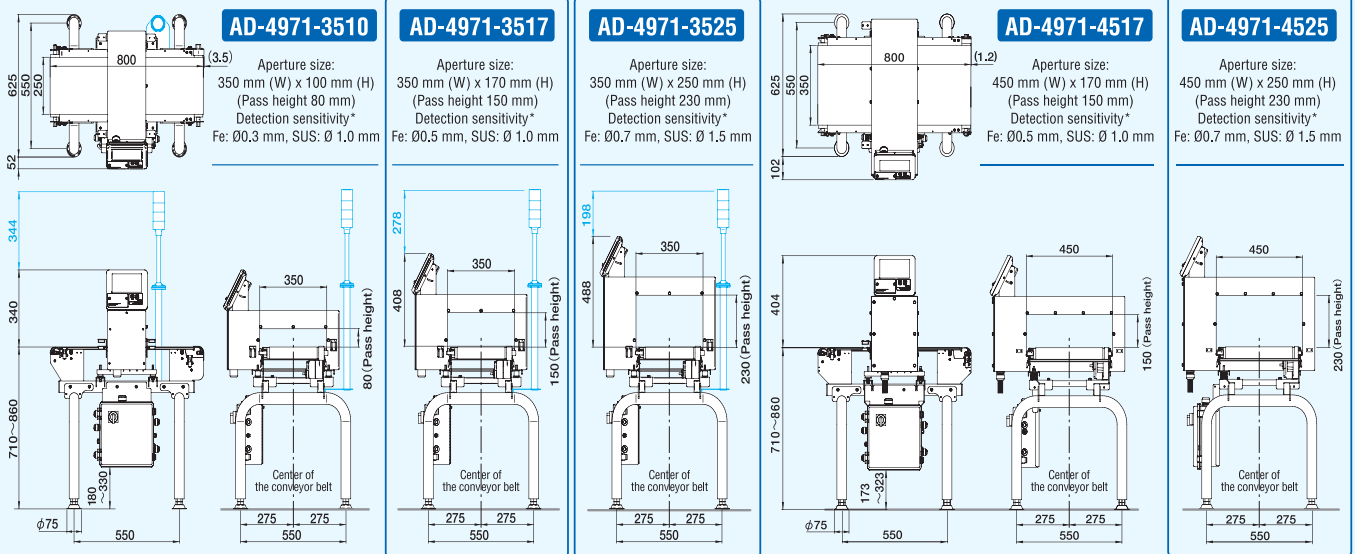

Model	Part Number	Price (ex GST)
In Line Metal Detector 350mm x 100mm aperture	03055500	POA
In Line Metal Detector 350mm x 170mm aperture	03055700	POA
In Line Metal Detector 350mm x 250mm aperture	03055600	POA
In Line Metal Detector 450mm x 170mm aperture	03056100	POA
In Line Metal Detector 450mm x 250mm aperture	03056200	POA
S/S lockable reject bin (free standing)	03055017-A	POA
Various reject modules available	refer to CW options	POA
Motor Assembly (350mm)	7PM-4971-MO1	\$850
MD test samples with certificates (Fe, non-Fe, SUS304, SUS316)	VARIOUS	\$60 each



# AD-4976

## Food Grade Metal Detectors



**Modular Metal  
Detector  
head available  
seperately.**



Specifications	AD-4976
Max belt speed	10-50m/min Urethane belt
Carrying capacity (350W)	5kg (~30m/min) 3kg (30~50m/min)
Carrying capacity (450W)	10kg (10~20m/min) 3kg (40~50m/min)
Display	7inch colour LCD Touch Panel
Conveyor length	800mm
Conveyor speed	10 - 50m/min
No. of recorded items	1000
Ethernet	10 Base-T/100Base-T Auto-MDIX
Modbus	Modbus RTU & TCP available
350 Dims (100mm)	Pass Height: Max 80mm
350 Dims (170mm)	Pass Height: Max 150mm
350 Dims (250mm)	Pass Height: Max 230mm
450 Dims (170mm)	Pass Height: Max 150mm
450 Dims (250mm)	Pass Height: Max 230mm
Water/Dust resistance	IP66 Stainless Steel
Power Supply	AC 100-240V With Emergency Function

\* Detection sensitivity will change depending on product and environmental conditions.  
Please prepare a φ4-7mm power cable.

- **Protected from dust and water to IP66 standards**

- Hygienic design considerations
- Suitable for use in HACCP program
- Automatic sensitivity setting function
- Easy operation with 7-inch color touch panel
- Variable belt speed of 10-50m/min
- Standard Ethernet I/O; easy networking via LAN
- Inspection history function with the ability to record 100 inspection results in the internal memory
- Capacity can be increased by using USB memory
- Cleaning and maintenance is simple with a detachable conveyor belt (width 350mm; length 800mm)
- Available in a head only configuration and can be mounted vertically for use in bottling applications

Model	Part Number	Price (ex GST)
DeteX In Line Metal Detector 350mm x 100mm aperture	03055550	POA
DeteX In Line Metal Detector 350mm x 170mm aperture	03055660	POA
DeteX In Line Metal Detector 350mm x 250mm aperture	03055670	POA
DeteX In Line Metal Detector 450mm x 170mm aperture	03055690	POA
DeteX In Line Metal Detector 450mm x 250mm aperture	03055680	POA
S/S lockable reject bin (free standing)	03055017-A	POA
Various reject modules available	refer to CW options	POA
Motor Assembly (350mm)	7PM-4971-MO1	\$895
MD test samples with certificates (Fe, non-Fe, SUS304, SUS316)	VARIOUS	\$60 each



# Label Printers

## Thermal Printing



Easy stand-alone label printing TCS Keyboard option

### TSC TE210

Plus Thermal Transfer & Direct Thermal (108mm wide) Value Printer

### TSC TTP-247

Plus Thermal Transfer & Direct Thermal (108mm wide) Industrial Printer



Examples of programming for labels

Specifications	TE210	TTP-247
Price (ex GST)	\$575	\$740
Part Number	06090828	06090827
Resolution	203 dpi	203 dpi
Print width	108mm	108mm
Print Length	2540mm	2286mm
Weight	2.5kg	2.8kg
Dimensions (mm)	204 (L) x 280(W) x 188(H)	213 (L) x 314(W) x 188(H)

```
ST, +002658.9 g
2019/06/18 14:33:01
```

***\*Other labels and programming options available. Please speak to A&D about your requirements.***

Accessories*	Part Number	Price (ex GST)
Standard Programming per Printer (weight, date, time, company name only)	LB	\$200
102x102mm 625/roll labels	06090826	\$35
102x48mm 1000/roll labels	06090822	\$35
102x25.4mm 2000/roll labels	06090821	\$35
56x25mm 800/roll label	06090811	\$25
56x46mm 1000/roll label	06090812	\$30
RS232 Cable DB9 Male-DB9 Female	03000008	\$60
RS232 Cable DB9 Male-DIN Male	03000009	\$60
TSC Keyboard	Enquire	POA

## A&D WinCT Software

### Available Software

WinCT Version 5.40 for Balances, Scales & Indicators including RsCom / RsKey / RsWeight

WinCT-Plus Software

AD-1688 Set-up Software

WinCT Viscosity Software

WinCT Moisture Software

LabVIEW® Driver Software

WinCT-UFC for FC-i, HC-i, AD-4405/06/07

WinST Software

WinCT Version 3.00 for Balances, Scales & Indicators including RSWeight feature

**Contact your Account Manager for full details**

# Peripherals

## AD-1683 / AD-720Di / Remote Displays / AD-8922A



### AD-1683 STATIC ELIMINATOR



- The AD-1683 generates positive and negative ions to eliminate static electricity, which is often the cause of inaccurate weighing.
- Ideal for treating your glassware, petri dishes, samples,...
- Can be easily and safely installed because it requires no high-voltage wiring
- Compact and lightweight.
- Little or no reverse charge is induced by irradiated ions because of its excellent ion polarity balance

Specifications	AD-1683 STATIC ELIMINATOR
Price (ex GST)	<b>\$1,930</b>
Part Number	<b>06087300</b>
Dimensions	112(W) x 92(D) x 40(H) mm
Power supply	TB-S200 (included)

### AD-720Di DOT MATRIX PRINTER



- Date and Time
- Portable and light weight
- Dot-Matrix mechanism, statistic function
- Matrix printer with superior readability
- Powered by AC adaptor
- Compatible with all A&D balances and scales and a wide range of other electronic balances, indicators.

Specifications	AD-720Di PRINTER
Price (ex GST)	<b>\$650</b>
Part Number	<b>06088906</b>
Dimensions	174(W) x 141(D) x 86.9(H) mm
Power supply	TB-301

Accessories	Part Number	Price (ex GST)
Printer Paper Roll (each)	MAWP-PP-AD7xx	\$20
Printer ribbon	MAET-ECR09	\$50

Please specify which cable connection is required when placing your order

### REMOTE DISPLAYS

#### AD-8920A Display 13mm digits



#### TD-3000 Display (IP65) 75mm digits



The TD-3000 is supplied with bare wires as standard. If you would like us to make a cable with a din plug please specify the cable connection required when placing the order using LB part number specified below.

Connects to A&D's balances and scales using either RS-232C or current loop. ideally suited to any A&D Balance or Scale

Specifications	AD-8920A	TD-3000
Price (ex GST)	<b>\$540</b>	<b>\$840</b>
Part Number	<b>06086700</b>	<b>06086786</b>
Dimensions (mm)	128(W) x 102(H) x 76(D)	447(W) x 141(H) x 174(D)

Accessories	Part Number	Price (ex GST)
TD-3000 cable connection	LB	\$55



#### AD-8922A REMOTE CONTROLLER

The AD-8922A is a remote controller that can be connected to an A&D manufactured weighing instrument using the RS-232C serial interface.

- Displays weighing data.
- Compact and lightweight.
- Remotely controls a weighing instrument with key operations

Specifications	AD-8922A Controller
Price (ex GST)	<b>\$1,000</b>
Part Number	<b>06087512</b>
Dimensions (mm)	238(W) x 170(H) x 132(D)



# Peripherals

## AD-1688 / AD-8527 / AD-1687 / AD-1691

### AD-1688 WEIGHING DATA LOGGER



Save, Store & Retrieve - EASY!

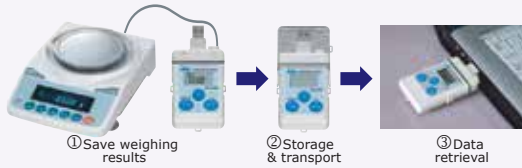

- Dual Interface to import data from an A&D balance to a PC
- No battery. It receives power directly from the balance or PC
- Large memory: up to 5,000 weighing data sets can be stored
- Internal clock and interval mode

Specifications	AD-1688 WEIGHING DATA LOGGER
Price (ex GST)	<b>\$300</b>
Part Number	<b>09022000</b>

### AD-8527 QUICK USB ADAPTOR



AD-8527 does 2 things:

- Transmits weighing data directly via the RS-232C port of an A&D balance or scale to the USB port of a PC
- Makes the data available at application level



- Easy to use - no software or driver installation required
- Eliminates operator errors
- Note: EJ balances requires USB to USB cable

Specifications	AD-8527 QUICK USB ADAPTOR
Price (ex GST)	<b>\$300</b>
Part Number	<b>09023000</b>

ACCESSORIES

AD-1641 Air Flow Sensor is sold separately.

### AD-1687 WEIGHING ENVIRONMENT LOGGER



- Simultaneous and chronological recording of environmental and weighing data.
- Four kinds of environmental data can be added to your records:
  - Temperature (°C / °F),
  - Humidity (%),
  - Barometric pressure (hPa),
  - Vibration (mG)
- Large memory capacity of 10,000 data sets
- Graphic and numeric display of information
- Connects to balance by RS-232C and to PC by USB
- Time stamping of data

Specifications	AD-1687 WEIGHING ENVIRONMENT LOGGER
Price (ex GST)	<b>\$840</b>
Part Number	<b>06037000</b>

### AD-1691 WEIGHING ENVIRONMENT ANALYSER

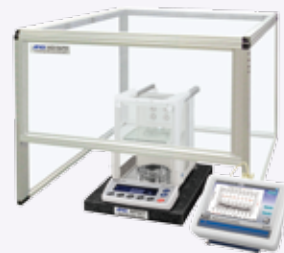

- Easy operation by following step-by-step guidance on a color touch-panel screen
- Daily balance LCD check to confirm that the balance meets proper conditions for use
- Quick glossary for periodic check items
- Documentation of daily/periodic check / calibration results
- Assessment of measurement environment using AND-MEET\*1 with the BM series
- Remote balance display and control
- Date and time setting
- Adjustable LCD brightness
- Three kinds of RS-232C cables as standard

Specifications	AD-1691 WEIGHING ENVIRONMENT LOGGER
Price (ex GST)	<b>Please Enquire</b>
Part Number	<b>06037100</b>

Accessories	Part Number	Price (ex GST)
AD-1641 Air Flow Sensor	06036370	POA



# Peripherals

BT Adapters / BT Converters / Remote Display / RS-232-USB



## BLUETOOTH CONVERTERS



**AD-8529PC-W  
FOR PC**



**AD-8529PR-W  
FOR PRINTER**

These bluetooth converters enables the RS-232C connection to be wireless between the measurement device and the PC or the printer.

Specifications	AD-8529PR-W	AD-8529PC-W
Price (ex GST)	\$460	\$460
Part Number	09024010	09024000



**RS-232  
TO USB  
CONVERSION  
CABLE**

This RS-232 (Male) to USB conversion cable can be used in conjunction with the serial data cables for peripheral connection allowing the connection of A&D equipment to devices that will only receive USB.

Specifications	(Male) RS232 TO USB
Price (ex GST)	\$100
Part Number	03000006

## SENA BLUETOOTH SERIAL ADAPTER & USB BT ADAPTER

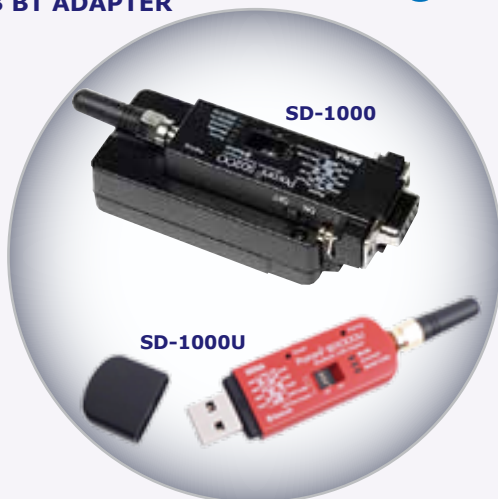

**SD-1000**

**SD-1000U**

- Sena SD1000 Long Range Bluetooth Serial Adapter.
- Sena SD1000U Long Range Bluetooth-USB Adapter for Serial Port Replacement.

Specifications	SD-1000	SD-1000U
Price (ex GST)	\$330 (EACH)	\$300 (EACH)
Part Number	06087502	06087508

## BLUETOOTH CONVERTOR FOR PC & WIRELESS REMOTE DISPLAY



**AD-8541**

**AD-8931**

- Ideal options for use with SJ-WP-BT scales
- Portable and compact units

Specifications	AD-8541	AD-8931
Price (ex GST)	\$200	\$200
Part Number	09024030	06086710

# Bluetooth Connectivity Guide



## BLUETOOTH CONNECTIVITY

AD-4406, AD4407, EJ SERIES, GX-A SERIES, GF-A SERIES, FX-i SERIES  
FZ-i SERIES, FG SERIES, FS-Ki SERIES, SE SERIES, SC SERIES

These are a number of A&D products that can interface with bluetooth.  
This range can change, so speak to your Account Manager for the full,  
current list of bluetooth compatible products.

# Moisture Analysers

## Fast and Uniform Heating

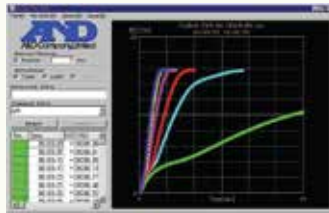

- **Fast & uniform heating with halogen lamp and innovative SRA technology**
- Sample size up to 70g with SHS (Super Hybrid Sensor) and high repeatability
- Can measure moisture content of up to 0.001% resolution
- Standard WinCT-Moisture software for real-time graph displaying on PC (MS & MX only)
- Up to 20 suitable measurement conditions can be stored and recalled, saving time and minimising errors
- Five programmable modes: Standard, Automatic, Quick, Timer & Manual modes
- Selectable heating modes: Standard, Quick, Step & Ramp modes (ML has Quick & Standard modes only)
- Long life halogen lamp is in protective chamber for easy cleaning and lamps can be easily replaced

Specifications	MS-70	MX-50	MF-50	ML-50
<b>Price (ex GST)</b>	<b>\$7,570</b>	<b>\$4,640</b>	<b>\$3,950</b>	<b>\$2,520</b>
<b>Part Number</b>	<b>06036950</b>	<b>06036900</b>	<b>06036400</b>	<b>06036450</b>
Capacities	71g x 0.0001g	51g x 0.001g	51g x 0.002g	51g x 0.005g
Product Description	400W straight halogen lamp heating system with SRA filter and SHS weighing technology			
Moisture Content Display	0.001%/0.01%/0.1%	0.01%/0.1%	0.05%/0.1%/1%	0.1%/1%
Moisture Content <sub>over1g</sub>	0.05%	0.10%	0.20%	0.5%
Accuracy (Std.D) <sub>over5g</sub>	0.01%	0.02%	0.05%	0.1%
Memory Programs	20 sets		10 sets	5 sets
Data Memory Function	100		50	30
Heating Mode (400W max)	Standard/Quick/Step/Ramp			Standard/Quick
Measurement Programs	Standard Mode / Automatic Mode / Quick Mode / Timer Mode / Manual Mode			
Power Supply	AC Mains			

Accessories	Part Number	Price (ex GST)
Serial Cable DB25 Male to BD9 Female	03000001	\$60
MS/MX/MF/ML Halogen lamp (240v 400W)	MAAX-34-240V	\$240
MS/MX/MF/ML Reusable trays (100 pieces) 85mm	MAAX-31PANMXMF	\$310
Disposable Aluminium pans (100 pieces)	MAAX-30PAN-MX	\$150
MS/MX Temperature calibration meter	MAAX-43CALMX	\$1,170
MS/MX/MF/ML Plastic display cover (Pack of 2)	MAAX-38COVERMXMF	\$120
MS/MX/MF/ML 15.66% test sample (30g x 12pcs)	MAAX-33TESTMXMF	\$420
MS/MX/MF/ML 15.66% test sample (each)	MAAX-33TESTMXMF-S	\$50
WinCT-Moisture Software	<i>Please Enquire</i>	\$130
Glass Fibre Sheet (78mm 100pcs)	AX-MX-32-2	\$80



# Vibro Viscometers

## Unique SV Viscosity Technology

Unique SV Viscosity Technology!



2ml sample measurements (SV-1A)



SV-10/100

● **With FREE PC Connectivity and Windows graphing software**

- Wide measurement range: 0.3 – 10 000mPa-s for SV-10, and 1 000 – 100 000mPa-s for SV-100
- Measure very low viscosities (down to 1/3 of water viscosity!), Temperature measurement from 0 to 160°C
- Fast measurements: 1<sup>st</sup> result within 15 seconds, and refresh in real time
- Possible continuous measurements in order to characterize changes of state
- High precision with a repeatability of ±1% of displayed value
- Small size sample: cups of 35ml, 13ml, 10ml, and even tubes of 2ml (with SV-1A)
- Possibility to do measurements directly into your containers: beakers, product packages...
- Low mechanical and thermal impact: Preservation of sample characteristics and its texture
- Measurements possible on foaming samples, on foam itself, on flowing or agitated samples
- Simple operation: no configuration - just push on the start button, easy to clean
- Calibration (judgement and even adjustment) of viscosity possible by the user: 1 or 2 points
- Simplified and automated calibration (including adjustment) with pure water (SV-10)

Specifications	SV-1A	SV-10A	SV-10	SV-100
Price (ex GST)	<b>\$12,050</b>	<b>\$12,050</b>	<b>\$9,640</b>	<b>\$9,640</b>
Part Number	<b>06090101</b>	<b>06090102</b>	<b>06090100</b>	<b>06090200</b>
Product Description	0.8-1000 cP / 0.8-1000mPa/s	0.3-10,000 cP / 0.3-10,000mPa/s	0.3-10,000 cP / 0.3-10,000mPa/s	1-100Pa/s
Measurement range	0.3~1000mPa.s	0.3~10,000mPa.s	0.3~10,000mPa.s	1000~100000mPa.s
Measurement units	mPa.s, Pa.s, cP, P	mPa.s, Pa.s, cP, P	mPa.s, Pa.s, cP, P	Pa.s, P
Sample size	2ml~	10ml~	1ml~	1ml~
Temperature range	0~160°C / precision 0.1°C			
Power Supply	AC Adaptor TB-S139 included			

Accessories	Part Number	Price (ex GST)
Serial Cable DB25 Male to DB9 Female	03000001	\$60
AX-SV-34 10ml Sample cup (10pcs)	MAAX-SV-34	\$300
AX-SV-33 35ml Sample cup (10pcs)	MAAX-SV-33	\$300
AX-SV-58 2ml Sample cup (100pcs)	MAAX-SV-58	\$480
AX-SV-35 13ml Glass Sample Cup	MAAX-SV-35	\$490
AX-SV-36 Vertical Position Lock	MAAX-SV-36	\$360
AX-SV-37 Water Jacket Unit	MAAX-SV-37	\$540
AX-SV-42 Analog Output (0-1V)	MAAX-SV-42	\$1,690
AX-SV-43 5m Display Extension Cable	MAAX-SV-43	\$600



# Vibro Rheometers

## Tuning Fork Vibro Rheometer Technology



- **Vibro Rheometer with excellent Sensitivity & Repeatability**
- Repeatability as high as 1% of the measured value (by S.D.) even with low viscosity sample fluids
- Shear rate changes by controlling the sensor plate vibration amplitude
- Easy setup/cleaning and very quick measurement (stabilization in 20 seconds)
- Wide continuous measurement range (max. 0.3 to 25,000 mPa·s)
- Little interference to the sample fluid
- Possible to measure fluids in motion

Specifications	RV-10000A VIBRO RHEOMETER		
<b>Price (ex GST)</b>	<b>\$POA</b>		
<b>Part Number</b>	<b>06090103</b>		
Product Description	Tuning fork vibro method (natural frequency at 30Hz)		
Variable amp. range	0.07 to 1.2mm (peak-to-peak at the tip of the sensor plate)		
Repeatability	1% of the measured value (standard deviation)		
Minimum Display	Range 0.3 to 10 (mPa-s)	Min. Display 0.01 (mPa-s)	Min. Display 0.0001 (Pa-s)
	Range 10 to 100 (mPa-s)	Min. Display 0.1 (mPa-s)	Min. Display 0.0001 (Pa-s)
	Range 100 to 1000 (mPa-s)	Min. Display 1 (mPa-s)	Min. Display 0.001 (Pa-s)
	Range 1000 to 25000 (mPa-s)	Min. Display 10 (mPa-s)	Min. Display 0.01 (Pa-s)
Viscosity Units	mPa-s, Pa-s, cP, P		
Operating Temp.	10 - 40 degrees celcius, 50 - 104 degrees farhenheit		
Minimum sample	10 ml		
Display	Vacuum Fluorescent Display (VFD)		
Communication	RS-232C as standard		
Power Supply	AC Adaptor TB-S139 included		

Accessories	Part Number	Price (ex GST)
AD-1687 Environment logger	06037000	\$840

# Testing Products

## Pipettes Accuracy Testers



Pipette is not included



Carry Case



AD-4212A-PT



FX-300i-PT



AD-1690 Leak Tester

- **Save \$\$\$ in unnecessary external Pipette Testing!**

- Very short stabilization times thus increasing the productivity of your pipette calibration activities.
- Compliance with ISO8655 or any other specifications based on the "gravimetric method"

- Standard liquid thermometer and evaporation trap to ensure as precise measurements as possible
- Includes a calibration weight and tweezers for the balance
- Accuracy Testers - Evaporation Trap & Win CT Software included
- AD-1690 Leak tester - Quick 5 seconds test will determine damaged pipettes

Specifications	AD-4212A-PT	FX-300i-PT
Price (ex GST)	<b>\$10,810</b>	<b>\$4,820</b>
Part Number	<b>06090301</b>	<b>06090302</b>
Product Description	Pipette Tester	Pipette Tester
Capacity	110g	320g
Resolution	0.1mg	1mg
Compliance	ISO8655 or other specification based on "gravimetric method"	
Power Supply	AC Adaptor TB-301	AC Adaptor TB-S139

Accessories	Part Number	Price (ex GST)
AD-1690 Pipette Leak Tester	06090303	\$2,740
OP-01 Tube Set (AD-1690)	06090304	\$350
OP-02 Filter Set (AD-1690)	06090305	\$350

## AD-1653 / AD-1654

### Density Determination Kit

The density determination kits (when combined with an analytical or precision balance) allows the density or specific gravity of a solid or liquid to be measured easily and accurately based on Archimedes' Principle.

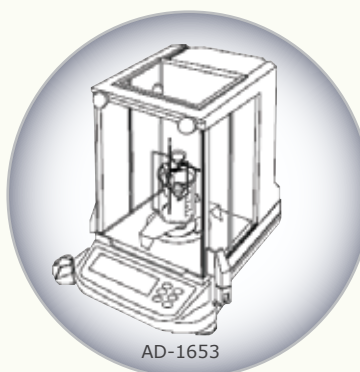

AD-1653

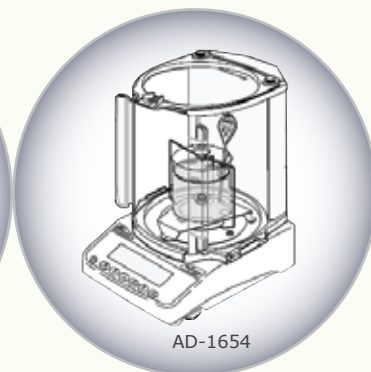

AD-1654

Specifications	AD-1653 DENSITY KIT	AD-1654 DENSITY KIT
Price (ex GST)	<b>\$1,210</b>	<b>\$1,190</b>
Part Number	<b>06036300</b>	<b>06036350</b>
Applicable balances	BM Series / GH Series / GR Series	HR-AZ / HR-A Series / FZ-i Series / FX-i Series

# MC Series

## Mass Comparator Precision Balances



- Used for Mass Verification
- Precision balance with extended resolution



MC-10K

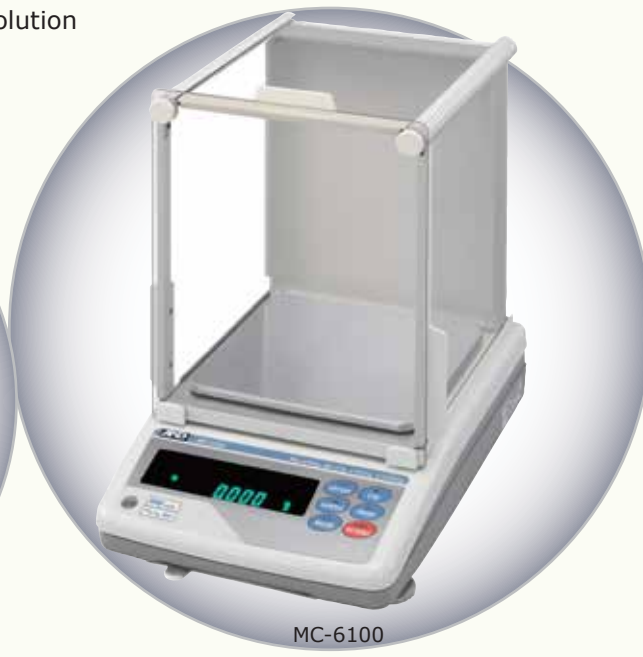

MC-6100

- (MC-10K/30K) Accumulation Function
- (MC-10K/30K) IP65
- Internal Calibration
- GLP Compliant
- RS-232C Interface
- Counting Function
- SHS Super Hybrid Sensor
- Comparator Function
- VFD Display
- Underhook
- Software
- Animal Weighing
- Percentage Function

### • Auto-centering pan is included as standard

- Extra decimal place for monitoring fine weight changes with heavy tare weights
- Stabilizing filter to lessen errors due to drafts or vibrations
- Internal calibration mass for simplified calibration of the balance
- Equipped with a glass breeze break (MC-1000/6100) or simple breeze break (MC-10K/30K) as standard
- Fast stabilization of approx. 1.5 seconds
- GLP/GMP/GCP/ISO compliant output
- Large bright vacuum fluorescent display
- Multiple weighing units of measurement



Mass Comparator uses auto-centering pan to correct eccentricity load to achieve higher accuracy.

Specifications	MC-1000	MC-6100	MC-10K	MC-30K
Price (ex GST)	\$10,810	\$10,810	\$11,470	\$12,040
Part Number	06036010	06036060	06036000	06036030
Capacity	1100g	6100g	10.1kg	30kg
Resolution	0.0001g	0.001g	0.001g	0.01g
Dimensions	210(W) x 317(D) x 86(H) mm		300(W) x 355(D) x 111(H) mm	
Pan Size	128mm x 128mm	165mm x 165mm	270mm x 210mm	
Serial Cable	DB9 Female to DB9 Female (03000007)			
Power Supply	AC Adaptor TB-S139 included			

ex Japan

Accessories	Part Number	Price (ex GST)
Replacement auto centering pan (MC-10K/30K)	06036001	\$1,690

ex Japan



# AD-4212A

## Analytical Production Weighing System

Software	Super Hybrid Sensor
SmartRange	External Calibration
RS-232C Interface	GLP Compliant
LCD Display	Percentage Function
Comparator Function	Counting Function
Options	
LAN-Ethernet Interface	

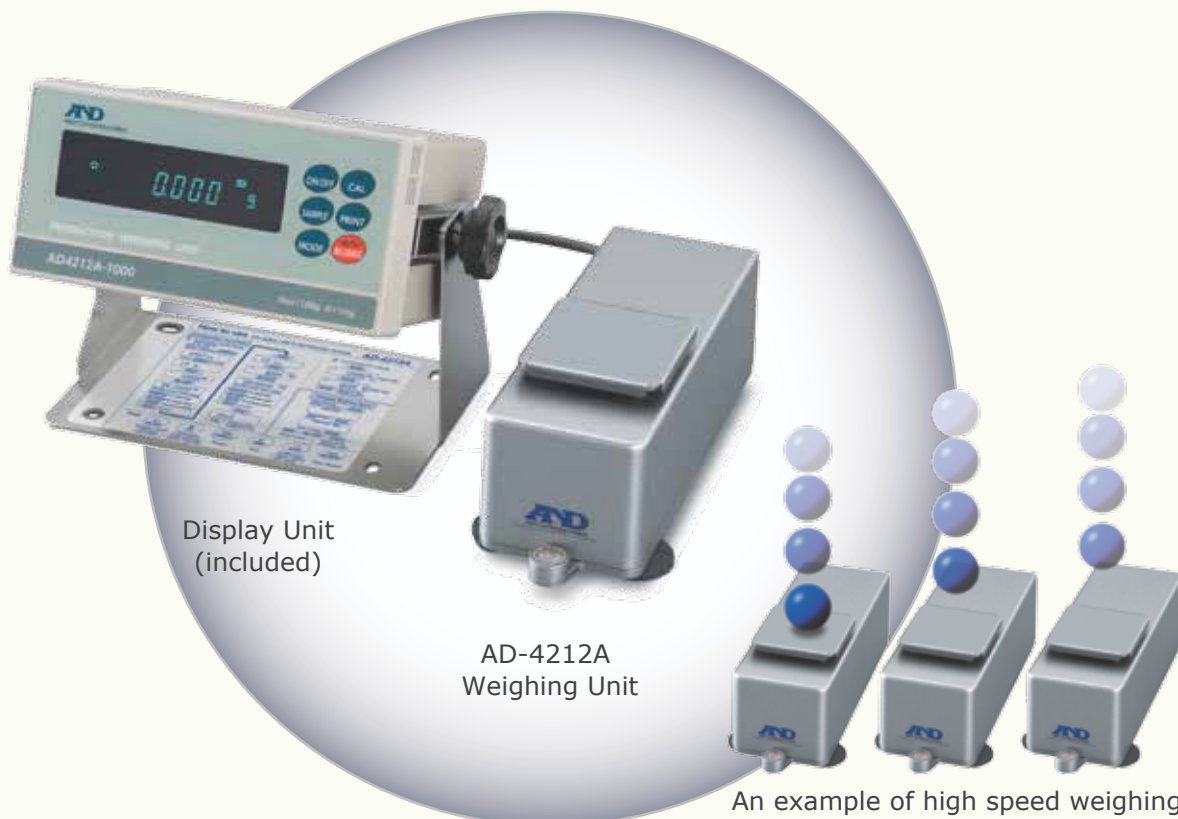

Display Unit (included)

AD-4212A Weighing Unit

An example of high speed weighing

For maximum efficiency of your production line

Applications such as:

- High-speed weighing
- High-speed check weighing
- Filling & Dispensing
- Isolated weighing

- High resolution and quick stabilization times down to: 1.1 seconds for 0.1mg & 0.8 seconds for 1mg
- Chemically resistant stainless steel sensor unit
- 3-level comparator with contact output and buzzer
- External digital inputs to trigger actions such as RE-ZERO or PRINT
- Data memory, GLP and GMP compliant
- Win CT: software tool for data acquisition from PC
- Multiple weighing units
- VFD screen for easy to read weighing results
- 2m connection cable in between sensor and indicator
- Protection against vertical or transverse shocks - patented

Specifications	AD-4212A-100	AD-4212A-200	AD-4212A-600	AD-4212A-1000
Price (ex GST)	POA	POA	POA	POA
Part Number	<b>06080310</b>	<b>06080320</b>	<b>06080300</b>	<b>06080330</b>
Capacity	110g	210g	610g	1100g
Resolution	0.0001g	0.001g	0.001g	0.001g
Dimensions	Weighing unit: 80(W) x 230(D) x 90(H); Display unit: 237(W) x 150(D) x 155(H) mm			
Pan Size	50mm x 50mm		70mm x 70mm	
Connection Cable	Approx. 2m between weighing unit and display unit			
Power Supply	AC Adaptor TB-301 included			

ex Japan



# AD-4212B

## Analytical Production Weighing System



Display Unit  
(included)

AD-4212B  
Weighing Unit



Ideal for applications such as:

- High-speed weighing
- High-speed check weighing
- Filling
- Isolated weighing

High Speed  
Durable  
Compact  
Precise Filling

- High resolution and quick stabilization times down to: 2.5 seconds for 0.1mg & 4 seconds for 0.01mg
- Standard RS-232C interface
- Chemically resistant stainless steel sensor unit
- 5-level comparator with contact output and buzzer
- External digital inputs to trigger actions such as RE-ZERO or PRINT
- Data memory, GLP and GMP compliant
- Win CT: software tool for data acquisition from PC
- Multiple weighing units
- VFD screen for easy to read weighing results
- 2m connection cable in between sensor and indicator
- Protection against vertical or transverse shocks - patented

Specifications	AD-4212B-101	AD-4212B-102	AD-4212B-201	AD-4212B-301
Price (ex GST)	POA	POA	POA	POA
Part Number	<b>06080602</b>	<b>06080350</b>	<b>06080800</b>	<b>06080360</b>
Capacity	31g / 110g	110g	210g	310g
Resolution	0.01mg / 0.1mg	0.01mg	0.1mg	0.1mg
Dimensions	Weighing unit: 80(W) x 230(D) x 90(H); Display unit: 237(W) x 150(D) x 155(H) mm			
Pan Size	Ø 34mm		50mm x 50mm	
Connection Cable	Approx. 2m between weighing unit and display unit			
Power Supply	AC Adaptor TB-301 included			



# AD-4212C / AD-4212L

## Production Line Weighing System

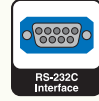

Options



AD-4212C Module



AD-4212L Module

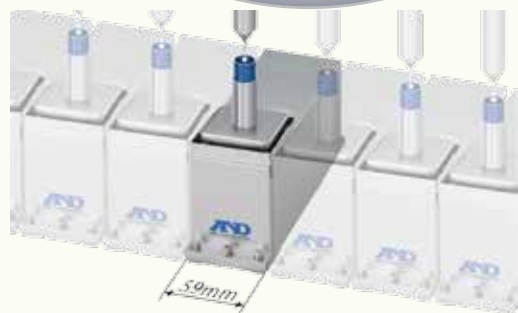

Option:  
AD-8922A  
Display Unit

### ● AD-4212C Features

- Fast stabilization (0.5 sec. at 1 mg and 1.3 sec. at 0.1 mg)
- Slim size (59 mm width) for installation in narrow spaces
- Direct digital data output to a panel computer, PLC/PC via RS-232C
- High-speed data transmission of up to 50 times/second
- IP65 dust and waterproof construction
- Protection mechanism against vertical and transverse overloading
- Removable levelling feet for direct attachment on the mounting base
- Calibration weight included
- Connection cable included (about 5 m)

### ● AD-4212L Features

- Powerful vibration cancelling filter
- Strong overload protection
- High-speed sampling 1000 times per second
- Compact size weighing unit
- Fast response time
- Din rail mounting type display unit

Specifications	AD-4212C-301	AD-4212C-300	AD-4212C-600	AD-4212C-3100	AD-4212C-3000	AD-4212L-R50	AD-4212L-R100
Price (ex GST)	POA	POA	POA	POA	POA	POA	POA
Part Number	06080370	06081200	06080900	06081000	06080380	06080200	06080210
Capacity	51g / 320g	320g	620g	510g / 3200g	3200g	51g	110g
Resolution	0.0001g / 0.001g	0.001g	0.001g	0.001g / 0.01g	0.01g	0.001g	0.001g
Dimensions	59(W) x 231(D) x 91(H) mm					35(W) x 101(D) x 110(H) mm	
Pan Size	50mm x 50mm					Ø20.5 mm	
Connection Cable	Approx 10m					Approx 10m	
Power Supply	AC Adaptor TB-301 included					DC 24V +10% - 15%	

● ex Japan

Accessories	Part Number	Price (ex GST)
AD-8922A Display Unit	06087512	\$1,000

# AD-4212D

## Micro Analytical Weighing Sensor



Precision of high-end laboratory analytical balances to production lines/systems with unprecedented flexibility and utility.  
High Resolution, High Stability & Space saving



Options



- Minimum weighing value from 1 µg
- EM-DLC\* technology for direct connection to a PC or PLC via RS232 output
- Compact size and resistance to vacuum state ideal for use in a glove box
- Stable measurement in a fume hood (for 0.1 mg readability only)
- Internal calibration function to ensure accuracy with one key press
- Protection mechanism against vertical and transverse overloading due to actuator malfunctions, etc.
- Adjustable response characteristics to help cope with the effects of drafts and vibrations
- Automatic zero display after data output
- Equipped with a small breeze break
- Possible to design and attach your preferred weighing pan/receptacle
- Clock and calendar function
- Underhook for weighing magnetic materials and density measurements
- GLP/GMP/GCP/ISO compliant output
- Built-in temperature sensor for temperature data output
- AD-4212D module only - no display included

Specifications	AD-4212D-33	AD-4212D-32	AD-4212D-302	AD-4212D-301
Price (ex GST)	POA	POA	POA	POA
Part Number	<b>06081110</b>	<b>06081120</b>	<b>06081100</b>	<b>06081130</b>
Capacity	32g	5.1 g / 32 g	320g	320g
Resolution	0.001mg	0.001 mg / 0.01 mg	0.01mg	0.1mg
Dimensions	With breeze break: 167.5(W) x 298(D) x 170(H); Without: 167.5(W) x 298(D) x 90(H) mm			
Pan Size	Ø34 mm		Ø50 mm	
Connection Cable	Approx. 2m between weighing unit and display unit			
Power Supply	AC Adaptor included			

ex Japan



# Health Scales



**UC-355  
PERSONAL SCALE**

- 250kg capacity with 200g resolution
- Portable and battery operated
- Approx. dims 415(L) x 360(D) x 38(H) mm

Specifications	UC-355 PERSONAL SCALE
Price (ex GST)	\$410
Part Number	09030901
Capacity	250kg*

\*UC-355: 100g resolution from 1-100kg & 200g resolution from 100kg - 250kg



**UC-352BLE BT  
PERSONAL SCALE**

- 200kg capacity with 200g resolution
- Durable glass plate. Battery Operated
- Approx. dims 300(L) x 300(D) x 30(H) mm
- Bluetooth capability

Specifications	UC-352 PERSONAL SCALE
Price (ex GST)	\$190
Part Number	09018400
Capacity	0-100kg x 100g / 100-200kg x 200g



**PERSONAL  
SCALES**

UC-321  
Series

UC-502  
Personal Scale

- UC-321 Series with 50g resolution
- UC-502 Personal Scale with 100g resolution
- Portable & Light weight
- Battery Operated

Specifications	UC-321	UC-502
Price (ex GST)	\$310	\$70
Part Number	09030200	09030102
Calibration	150kg x 50g	180kg x 100g
Dimensions	310(W) x 310(D) x 20(H) mm	300(W) x 300(D) x 24(H) mm

**AD-6121A  
PERSONAL SCALES**



- 150kg capacity with 100g resolution
- Portable & Light weight
- Battery Operated
- Approx. dims 320(L) x 315(D) x 35(H) mm

Specifications	AD-6121A
Price (ex GST)	\$420
Part Number	09030900
Capacity	150kg x 100g





# Health Scales



**PW-200-FG  
PROFESSIONAL PLATFORM SCALE**

- 200kg capacity with 20g resolution
- AC Adaptor (TB-S200A) or battery operated

Specifications	PW-200-FG
Price (ex GST)	\$1,050
Part Number	03160700
Capacity	200kg x 20g



**HVL-CS  
CHAIR SCALE  
220KG  
CAPACITY**

- 220kg capacity with 20g resolution
- Battery Operated.
- AC Adaptor (TB-S200A). Adaptor not included

Specifications	HVL-CS CHAIR SCALE
Price (ex GST)	\$2,270
Part Number	03040610
Capacity	220kg x 20g

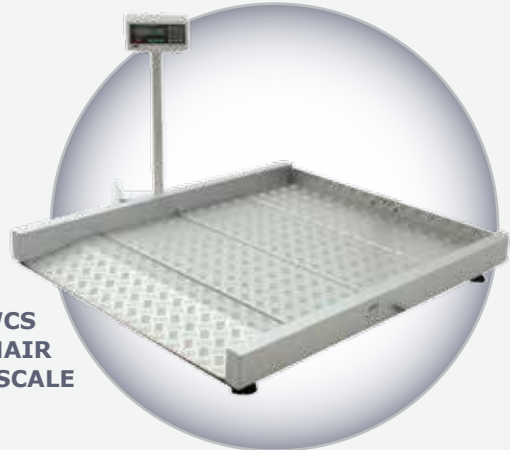

**WCS  
WHEELCHAIR  
SCALE**

- Highly portable with 300kg capacity
- Suitable for motorised or manual wheelchairs
- AC Adaptor or battery power operated
- Separate indicator for optimal positioning
- Handrail option available

Specifications	WHEELCHAIR SCALE
Price (ex GST)	\$4,895
Part Number	03040810
Capacity	300kg x 50g



**WALK-ON  
BARIATRIC  
SCALE**

- Large walk on platform: 600mm x 700mm
- High capacity 300kg x 100g
- AC Adaptor or battery power operated
- Easy wipe down with full armrest supports

Specifications	WALK ON BARIATRIC SCALE
Price (ex GST)	\$3,150
Part Number	03040710
Capacity	300kg x 100g

www.andaustralasia.com.au  
sales@andaustralasia.com.au

A&D alongside our valued National Dealer Network has gained an exceptional reputation for delivering quality, precision and reliability. Contact A&D to find your nearest A&D Dealer.

Head Office & Warehouse  
32 Dew Street  
THEBARTON  
South Australia 5031  
Tel: (08) 8301 8100  
Fax: (08) 8352 7409

New South Wales Office  
Unit 4, 14 Abbott Road  
SEVEN HILLS  
New South Wales 2147  
Tel: (02) 9674 5466  
Fax: (02) 9674 2544

Victorian Office  
Unit 38, 326 Settlement Road  
THOMASTOWN  
Victoria 3074  
Tel: (03) 9371 1555  
Fax (03) 9372 1193

Contact Your Local Western Australian Representative Today!



**Scientific  
Partners  
Australia**  
Your partner in science

Scientific Partners Australia  
Mob: 0447 733 832  
Fax: 08 9456 0363  
E: [sales@scientificpartners.com.au](mailto:sales@scientificpartners.com.au)

**A&D**  
Discover Precision  
A.B.N 26 007 556 809