

BROMIC[®]
REFRIGERATION

QUALITY MATTERS

CATALOGUE

20

22

Contact Your Local Western Australian Representative Today!



**Scientific
Partners
Australia**
Your partner in science

Scientific Partners Australia
Mob: 0447 733 832
E: sales@scientificpartners.com.au



Established in 1978 as a family business, The Bromic Group has grown to provide more than 100,000 high-quality products across three distinctly different divisions, supplying industries both internationally and throughout Australia.

Bromic Refrigeration was established in 1999, expanding from a core focus on plug-in refrigeration to sell more than 100,000 units into the Australian market across an expansive range of over 200 products.

As a division of the innovative and globally active Bromic Group, Bromic Refrigeration draws upon a pool of technically-talented engineers, experienced sales staff and friendly customer service representatives to satisfy the unique needs of businesses through a personalised, solution oriented approach to each and every customer.

Bromic is an ISO9001-certified company, committed to not only their exceptional corporate culture, but also the strength of long-standing supply partnerships with internationally acclaimed manufacturers that allow Bromic to distribute some of the highest value equipment in the country.

Quality matters to Bromic Refrigeration and we believe it to be an essential factor in the success of our products, carrying out rigorous product testing to ensure reliability while continuously improving energy efficiency as part of the GEMS scheme.

Partnered with world-renowned suppliers such as IARP, Simag, and Zanotti. Bromic Refrigeration is committed to distributing high-quality, durable equipment suited to the challenges presented by Australian businesses who understand that quality matters.

Legend



Bromic Refrigeration leads the way with continued development in utilising energy-efficient cooling solutions to help protect the planet.

Introducing **Green Cooling**: natural refrigerants which do not harm the ozone layer and have practically zero impact on global warming. Products with the Green Cooling logo have been manufactured utilising a natural refrigerant.



All Bromic Refrigeration products are sold with an **Extra Care Warranty**.



Bromic Extra Care is more than a standard warranty. It is a one-stop support service from Bromic experts for your peace of mind. Our friendly experts are easily accessible on the phone and can help resolve most issues in a single call. However, should there be a need, a technician can be on-site as fast as within 4h, depending on the issue severity. Our nationwide coverage means help is never too far away when you need it!



Warranty Terms vary across the range. Look for the warranty icons next to your product of choice to see what is applicable.

PROFESSIONAL RANGE

The **Bromic Professional Range** is an extensive range of high-performance equipment specifically manufactured to meet the demands of ultra-busy kitchens, restaurants, cafes, and other foodservice and retail applications. The Professional Range includes equipment manufactured by our exclusive global partners who are all leaders in their fields, such as Zanotti, IARP and Simag.

SPECIAL ORDER

The **Special Order** icon means that the product is available but may not be stocked, and therefore has an extended lead time. Please get in touch with your Bromic representative for more details.



CANNED DRINKS



FRUIT & VEGETABLES



BOTTLED DRINKS



PASTRIES



DAIRY PRODUCTS



ICE CREAM/GELATO



PACKAGED CHEESE



FROZEN PRODUCTS



PACKAGED MEAT



SANDWICHES



FRESH MEAT



SEAFOOD

ICE TYPES

SOLID CUBE ICE

REGULAR DICE ICE

HALF-DICE ICE

HOLLOW ICE

FLAKE ICE



FREEZER



FAN-FORCED



GENERAL USAGE

COUNTERTOP MERCHANDISERS 5

Countertop Beverage Fridges	7
Countertop Freezer	9
Specification Reference Guide	10

VERTICAL DISPLAY & STORAGE 11

Upright Display Fridges	13
Upright Storage Fridges	21
Upright Display Freezers	22
Upright Storage Freezers	24
Specification Reference Guide	25

BAR FRIDGES & FREEZERS 31

Back Bar Display Fridges	33
Back Bar Storage Fridges	34
Underbench Glass Door Display Fridges	35
Underbench Solid Door Storage Fridges	36
Underbench Solid Door Storage Freezers	37
Underbench Single Door Fridges & Freezer	38
Specification Reference Guide	39

CHEST FREEZERS 43

Display Chest Freezers	45
Display & Storage Chest Freezers	47
Specification Reference Guide	48

ISLAND FREEZERS 51

Irene ECO Island Freezers	53
Specification Reference Guide	54

GELATO DISPLAYS 55

Chest Freezer Gelato Displays	57
Gelato Displays	57
Specification Reference Guide	58

OPEN DISPLAYS 59

Vision ECO Open Displays	61
Specification Reference Guide	62

PIZZA PREP FRIDGES 63

Pizza Prep Fridges	65
Specification Reference Guide	66

FOOD DISPLAYS 67

Cold Food Displays	69
Hot Food Displays	71
Ambient Food Displays	73
Specification Reference Guide	74

ICE MACHINES 77

Types of Ice	79
Self-Contained Solid Cube Ice	80
Self-Contained Hollow Ice	82
Self-Contained Hollow & Flake ice	84
Modular Half-Dice Ice	85
Modular Flake Ice	86
Storage Bins	87
Water Filters	87
Daily Ice Production Overview Chart	88
Specification Reference Guide	89

REFRIGERATION SYSTEMS 93

Zanotti SB Series Drop-In	95
Zanotti ZN Series Slide-In	96
Zanotti GM Series Slide-In	97
Zanotti AS Series Rotary Systems	98
Zanotti Wine Block Slide-in Systems	99
Zanotti Wine Block Split Systems	100
Specification Reference Guide	101

MEDICAL REFRIGERATION 107

Medical Refrigeration	109
Specification Reference Guide	110

BROMIC HEATING 111

BROMIC PLUMBING & GAS 113

WARRANTY 115

Integrated lock and key
secures merchandise

High-impact LED
lights on all four sides
for perfect product
presentation

Double-glazed safety
glass doors increase
energy efficiency

Adjustable
corrosion-resistant
shelving for
flexibility in display
configuration

Ventilation guards
maintain air
circulation when
fully stocked

Illuminated lightbox
to highlight branding
(curved chillers only)

Digital temperature controller
and display enables quick
temperature adjustment

On/Off switch for lighting
and cooling to reduce
power consumption



Bromic's Countertop Merchandiser range entices impulse purchases by packaging products in a stylish unit surrounded on all sides by safety glass, achieving exceptional product visibility.

07. Countertop Beverage Fridges

Bromic's Countertop Beverage Fridges offer a stylish and durable display option for those wishing to encourage impulse beverage purchases at the point-of-sale.

LED strip lighting in all four corners maximises product visibility from all angles while purpose-designed ventilation guards ensure the unit's highly-efficient fan-forced motor can cool the cabinet evenly.

Options:

- Curved or flat glass to suit your style
- Colour match with white or black
- Illuminated light box decals highlight branding (POA)
- Operate at full capacity with 3 or 4 shelves + base



09. Countertop Freezer

Bromic's Countertop Freezer stylishly surrounds frozen goods in stainless steel while tempting passers-by to treat themselves with what lies behind its 4 triple-glazed safety glass sides.

Featuring simple static cooling above and below all 3 fixed shelves along with digital temperature control, this unit perfectly presents frozen goods at the point-of-sale.



10. Specification Reference Guide

Countertop Merchandisers

Countertop Beverage Fridges (Curved Glass)

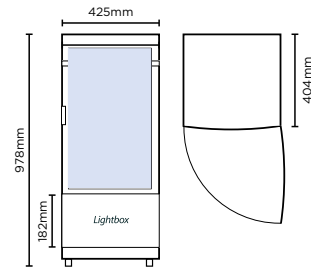

CT0080G4WC



Curved Glass 80L LED

Part No. 3735170 **Capacity** 80L **Weight** 38.5kg

	External (mm)	Internal (mm)
Width	425	367
Depth	404	306
Height	978	635

- 4-side LED lighting illuminates products from all angles
- Adjustable steel shelving with corrosion-resistant coating and ventilation guards
- Fast and even fan-forced cooling
- Temperature range: +2°C to +8°C
- 50mm feet included
- Display light box

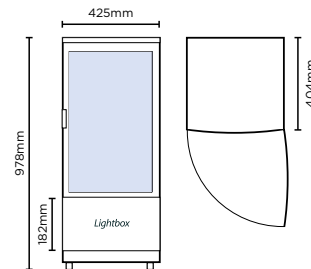

CT0080G4BC



Curved Glass 80L LED

Part No. 3735172 **Capacity** 80L **Weight** 38.5kg

	External (mm)	Internal (mm)
Width	425	367
Depth	404	306
Height	978	635

- 4-side LED lighting illuminates products from all angles
- Adjustable steel shelving with corrosion-resistant coating and ventilation guards
- Fast and even fan-forced cooling
- Temperature range: +2°C to +8°C
- 50mm feet included
- Display light box

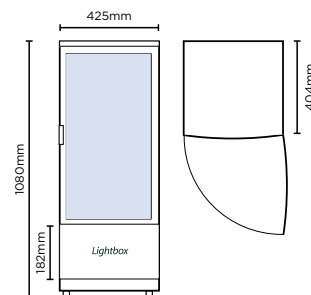

CT0100G4BC



Curved Glass 98L LED

Part No. 3735192 **Capacity** 98L **Weight** 41kg

	External (mm)	Internal (mm)
Width	425	367
Depth	404	306
Height	1080	785

- 4-side LED lighting illuminates products from all angles
- Adjustable steel shelving with corrosion-resistant coating and ventilation guards
- Fast and even fan-forced cooling
- Temperature range: +2°C to +8°C
- 50mm feet included
- Display light box

Countertop Merchandisers

Countertop Beverage Fridges (Flat Glass)

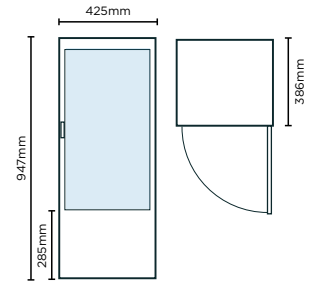
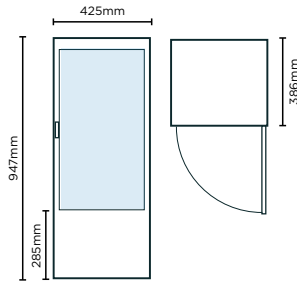

CT0080G4W



Flat Glass 78L LED

Part No.	Capacity	Weight
3735115	78L	36kg

	External (mm)	Internal (mm)
Width	425	369
Depth	386	309
Height	947	591

- 4-side LED lighting illuminates products from all angles
- Adjustable steel shelving with corrosion-resistant coating and ventilation guards
- Fast and even fan-forced cooling
- Temperature range +2°C to +8°C

CT0080G4B



Flat Glass 78L LED

Part No.	Capacity	Weight
3735176	78L	36kg

	External (mm)	Internal (mm)
Width	425	369
Depth	386	309
Height	947	591

- 4-side LED lighting illuminates products from all angles
- Adjustable steel shelving with corrosion-resistant coating and ventilation guards
- Fast and even fan-forced cooling
- Temperature range +2°C to +8°C

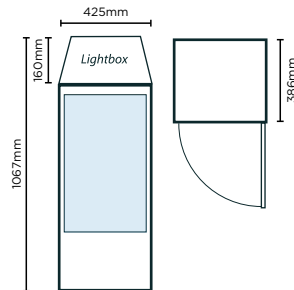

CT0080G4LW



Flat Glass 78L LED with Lightbox

Part No.	Capacity	Weight
3735131	78L	37kg

	External (mm)	Internal (mm)
Width	425	369
Depth	386	309
Height	1067	591

- 4-side LED lighting illuminates products from all angles
- Adjustable steel shelving with corrosion-resistant coating and ventilation guards
- Fast and even fan-forced cooling
- Temperature range +2°C to +8°C
- Display light box

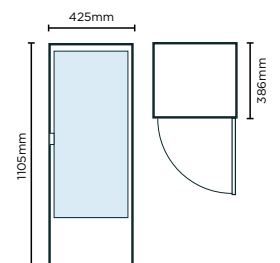

CT0100G4B



Flat Glass 98L LED

Part No.	Capacity	Weight
3735182	98L	40.5kg

	External (mm)	Internal (mm)
Width	425	369
Depth	386	309
Height	1105	785

- 4-side LED lighting illuminates products from all angles
- Adjustable steel shelving with corrosion-resistant coating and ventilation guards
- Fast and even fan-forced cooling
- Temperature range +2°C to +8°C

Countertop Merchandisers

Countertop Freezer

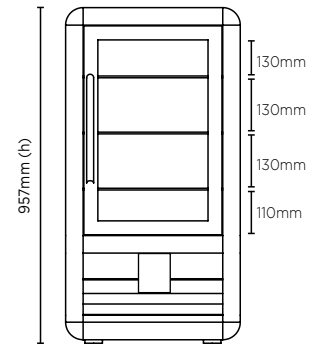

Front view

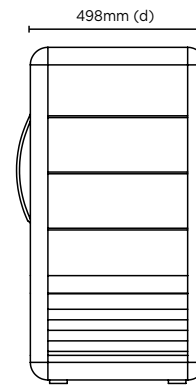

Side view

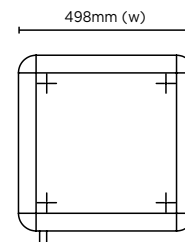

Top view

❄️ **CTF0100G4S**

SPECIAL ORDER

1 YEAR EXTRA CARE WARRANTY SERVICE

Countertop Freezer 100L LED

Part No.	Capacity	Weight
3735142	100L	76kg

	External (mm)	Internal (mm)
Width	498	422
Depth	498	413
Height	957	648

- Aluminium and stainless steel construction
- Static shelf cooling for long-term reliability
- Triple-glazed safety glass increases efficiency while reducing condensation
- Temperature range: -23°C to -15°C

Countertop Merchandisers

Specification Reference Guide

Fridge

Freezer

Model								SPECIAL ORDER
	CT0080G4WC	CT0080G4BC	CT0100G4BC	CT0080G4W	CT0080G4B	CT0080G4LW	CT0100G4B	CTF0100G4S
Part Number	3735170	3735172	3735192	3735115	3735176	3735131	3735182	3735142
Ext. Width (mm)*	425	425	425	425	425	425	425	498
Ext. Depth (mm)*	404	404	404	386	386	386	386	498
Ext. Height (mm)*	978	978	1080	947	947	1067	1105	957
Capacity	80L	80L	98L	78L	78L	78L	98L	100L
Temp. Range	+2 to +8°C	+2 to +8°C	+2 to +8°C	+2 to +8°C	+2 to +8°C	+2 to +8°C	+2 to +8°C	-23 to -15°C
Max. Ambient Temp.	32°C	32°C	32°C	32°C	32°C	32°C	32°C	32°C
Rated Power	164W	164W	164W	164W	164W	164W	164W	315W
Current	1.2A	1.2A	1.2A	1.2A	1.2A	1.2A	1.2A	1.2A
Gross Weight	38.5kg	38.5kg	41kg	36kg	36kg	37kg	40.5kg	74kg
Refrigerant	R134a	R134a	R134a	R134a	R134a	R134a	R134a	R134a
Plug Supplied	1	1	1	1	1	1	1	1
Power Supply	10A	10A	10A	10A	10A	10A	10A	10A
Features								
Display Light Box	✓	✓	✓			✓		
Main Light	LED	LED	LED	LED	LED	LED	LED	LED
Door Shape	Curved	Curved	Curved	Flat	Flat	Flat	Flat	Flat
Safety Glass	✓	✓	✓	✓	✓	✓	✓	✓
Door Lock	✓	✓	✓	✓	✓	✓	✓	
Temp. Controller	Digital	Digital	Digital	Digital	Digital	Digital	Digital	Digital
Feet Included	✓	✓	✓					✓
No. of Shelves Incl. Base	4	4	5	4	4	4	5	4
Colour	White	Black	Black	White	Black	White	Black	Silver
Warranty								
Parts (Years)	1	1	1	1	1	1	1	1
Labour (Years)	1	1	1	1	1	1	1	1

*Dimensions exclude lightbox & handle protrusions

1300 276 642

www.bromicrefrigeration.com.au

BROMIC
REFRIGERATION



Adjustable thermostat for accurate temperature maintenance

Powerful fan for even circulation of cold air

Metal door frame for durability and reliability (display units only)

Large illuminated display for maximum impact

Self-closing doors minimise temperature loss

Double-glazed (Fridges) or triple-glazed (freezers) safety glass doors increase energy efficiency

High-density polyurethane insulation keeps temperature and energy consumption low

Adjustable shelving for flexibility in display configuration (excluding static freezers)

High-impact internal lighting for perfect product presentation

Lockable castors make movement and placement easy

Bromic's Vertical Display & Storage range offers complete versatility, available in one-, two- and three-door configurations across a wide range of temperatures and styles.

13. Upright Display Fridges & Freezers

Bromic's Upright Display Fridges and Freezers offer reliability in a stylish casing, creating display solutions suited to self-service retail applications.

These dependable units achieve exceptional efficiency while maintaining longevity through simplicity.



16. LCD Video Fridge

Bromic's LCD Video Fridge introduces exciting movement to point-of-sale marketing, demanding the attention of customers by overlaying refrigerated products with relevant advertisements or imaginative entertainment.

This unit's 50-inch LG Ultra High Contrast LCD display resides within a double-glazed door and is able to switch rapidly between transparency and video content without sacrificing quality in bright environments.



21. Upright Storage Fridges & Freezer

Bromic's Upright Storage Fridges and Freezers prioritise reliability through simplicity to create an affordable storage solution.

This unit's corrosion-resistant outer casing is insulated on all four sides to minimise energy consumption by allowing the refrigeration system to operate efficiently only when it is needed.



23. Fan-Forced Upright Display Fridges & Freezers

Bromic's Fan-Forced Upright Display Fridges and Freezers are packed full of premium perks to ensure perfect performance in high-volume, self-service retail applications.

Defrosting and temperature are automatically regulated by the unit's digital controller while fast fan-forced cooling, heated glass doors and ambient ratings combine to keep products primed even in the harshest of Australian conditions.



25. Specification Reference Guide

Vertical Display & Storage

Upright Display Fridges

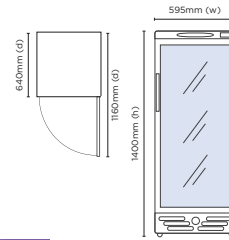

GM0220 LED ECO



Flat Glass Door 215L LED Display Fridge

Part No.	Capacity	Weight
3736033	215L	68kg

- High-impact LED lighting maximises product visibility and captures attention
- Double-glazed safety glass increases efficiency while reducing condensation
- Self-closing door for hassle-free self service
- Temperature range: +1°C to +10°C

	External (mm)	Internal (mm)
Width	595	505
Depth	640	462
Height	1400	1025

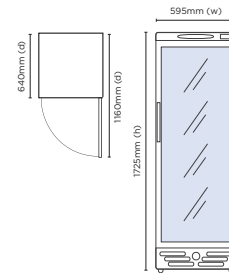

GM0300 LED ECO



Flat Glass Door 290L LED Display Fridge

Part No.	Capacity	Weight
3736034	290L	74kg

- High-impact LED lighting maximises product visibility and captures attention
- Double-glazed safety glass increases efficiency while reducing condensation
- Self-closing door for hassle-free self service
- Temperature range: +1°C to +10°C

	External (mm)	Internal (mm)
Width	595	505
Depth	640	462
Height	1725	1355

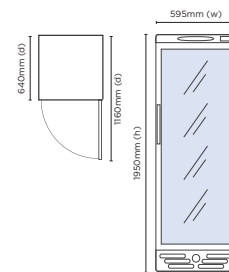

GM0374 LED ECO



Flat Glass Door 372L LED Display Fridge

Part No.	Capacity	Weight
3736035	372L	81kg

- High-impact LED lighting maximises product visibility and captures attention
- Double-glazed safety glass increases efficiency while reducing condensation
- Self-closing door for hassle-free self service
- Temperature range: +1°C to +10°C

	External (mm)	Internal (mm)
Width	595	505
Depth	640	462
Height	1950	1555

Vertical Display & Storage

Upright Display Fridges

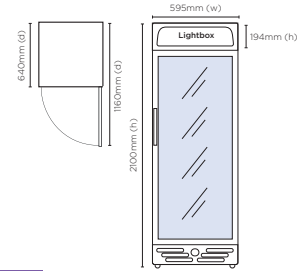

GM0374L LED ECO



Flat Glass Door 372L LED Display Fridge

Part No.	Capacity	Weight
3736036	372L	85kg

	External (mm)	Internal (mm)
Width	595	505
Depth	640	462
Height	2100	1555

- High-impact LED lighting and customizable lightbox capture attention
- Double-glazed safety glass increases efficiency while reducing condensation
- Self-closing door for hassle-free self service
- Temperature range: +1°C to +10°C

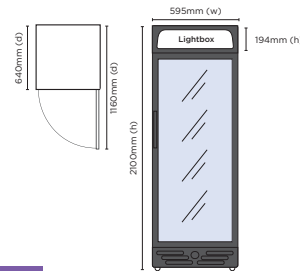

GM0374LB LED



Flat Glass Door 372L LED Display Fridge

Part No.	Capacity	Weight
3736092	372L	85kg

	External (mm)	Internal (mm)
Width	595	505
Depth	640	462
Height	2100	1555

- High-impact LED lighting and customizable lightbox capture attention
- Double-glazed safety glass increases efficiency while reducing condensation
- Self-closing door for hassle-free self service
- Temperature range: +1°C to +10°C

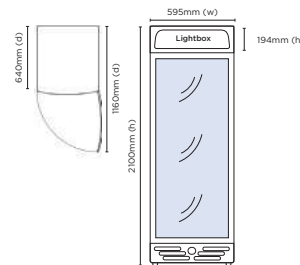

GM0400LC LED



Curved Glass Door 380L LED Display Fridge

Part No.	Capacity	Weight
3736037	380L	90kg

	External (mm)	Internal (mm)
Width	595	505
Depth	640	462
Height	2100	1555

- High-impact LED lighting and customizable lightbox capture attention
- Double-glazed safety glass increases efficiency while reducing condensation
- Self-closing door for hassle-free self service
- Temperature range: +1°C to +10°C

Vertical Display & Storage

Upright Display Fridges

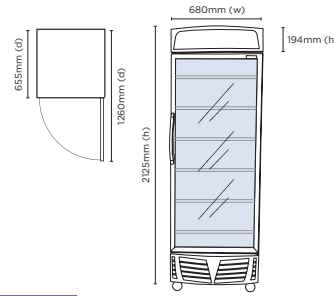

GM0440L LED



Flat Glass Door 438L LED Display Fridge

Part No.	Capacity	Weight
3736038	438L	110kg

	External (mm)	Internal (mm)
Width	680	580
Depth	655	495
Height	2125	1515

- High-impact LED lighting and customizable lightbox capture attention
- Double-glazed safety glass increases efficiency while reducing condensation
- Self-closing door for hassle-free self service
- Temperature range: +1°C to +10°C

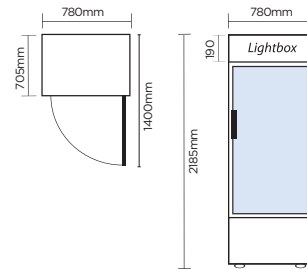

GM0690LW LED



Flat Glass Door 690L LED Display Fridge

Part No.	Capacity	Weight
3736219	659L	123kg

	External (mm)	Internal (mm)
Width	780	702
Depth	705	555
Height	2185	1682

- 43°C ambient temperature rating
- Double glazed Low-E glass doors reduce energy consumption and condensation
- High-impact internal lighting for superior product presentation
- Adjustable shelving for flexibility
- Illuminated light box to highlight branding
- Temperature range: +1°C to +5°C

FF

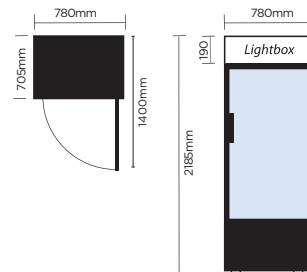

GM0690LB LED



Flat Glass Door 690L LED Display Fridge

Part No.	Capacity	Weight
3736222	659L	123kg

	External (mm)	Internal (mm)
Width	780	702
Depth	705	555
Height	2185	1682

- 43°C ambient temperature rating
- Double glazed Low-E glass doors reduce energy consumption and condensation
- High-impact internal lighting for superior product presentation
- Adjustable shelving for flexibility
- Illuminated light box to highlight branding
- Temperature range: +1°C to +5°C

FF



Vertical Display & Storage

Upright Display Fridges

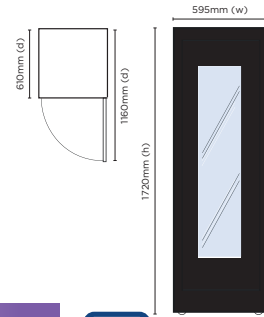

GMO300 RETRO

SPECIAL ORDER

1 YEAR EXTRA CARE WARRANTY SERVICE

Retro 290L LED Display Fridge

Part No.	Capacity	Weight
3736079	290L	85kg
External (mm)		Internal (mm)
Width	595	505
Depth	610	462
Height	1720	1555

- Front glass panel with green LED surround embedded into door glass
- Completely customisable 1950s-inspired retro unit that allows endless creative freedom*
- Temperature range: +1°C to +10°C

*Minimum quantity required



Wine Fridge

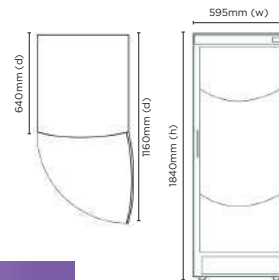

WC0400C LED ECO

1 YEAR EXTRA CARE WARRANTY SERVICE

Curved Glass Door 372L Wine Fridge

Part No.	Capacity	Weight
3735145	372L	84kg
External (mm)		Internal (mm)
Width	595	505
Depth	640	462
Height	1840	1555

- Reversible doors for complete flexibility
- 5 adjustable wooden shelves hold up to 50 bottles of wine
- Lockable castors make movement and placement easy
- Analogue controller with digital display for precise temperature maintenance
- Temperature range: +1°C to +18°C

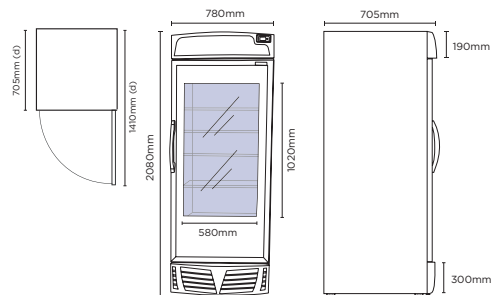

GMO690-VID

SPECIAL ORDER

1 YEAR EXTRA CARE WARRANTY SERVICE

LCD Video 657L Display Fridge

Part No.	Capacity	Weight
3736093	657L	136kg
External (mm)		Internal (mm)
Width	780	555
Depth	705	702
Height	2080	1682

- 50-inch LG Ultra-High Contrast LCD display
- 1080 x 1920 screen resolution with a super wide 178° viewing angle
- Self-closing door with stay for easy stocking and hassle-free self service
- Environmentally friendly R600 refrigerant
- Temperature range: +1°C to +10°C

Vertical Display & Storage

Upright Display Fridges

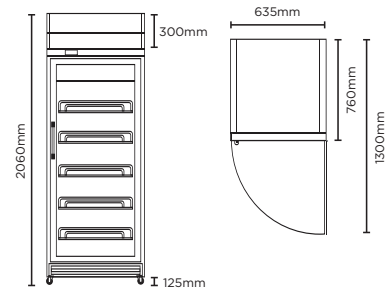

GD0500LF



Flat Glass Door 444L LED Display Fridges

Part No.	Capacity	Weight
3736245	444L	95kg

	External (mm)	Internal (mm)
Width	635	520
Depth	760	550
Height	2060	1420

- Double-glazed heated safety glass increases efficiency while reducing condensation
- Self-closing door with stay for easy stocking and hassle-free self service
- Temperature range: +2°C to +8°C

FF

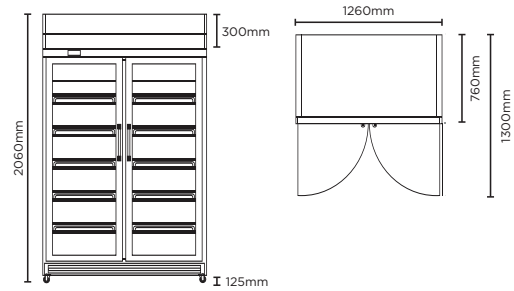

GD1000LF



Flat Glass Door 976L LED Display Fridges

Part No.	Capacity	Weight
3736246	976L	157kg

	External (mm)	Internal (mm)
Width	1260	1143
Depth	760	550
Height	2060	1420

- Double-glazed heated safety glass increases efficiency while reducing condensation
- Self-closing door with stay for easy stocking and hassle-free self service
- Temperature range: +2°C to +8°C

FF

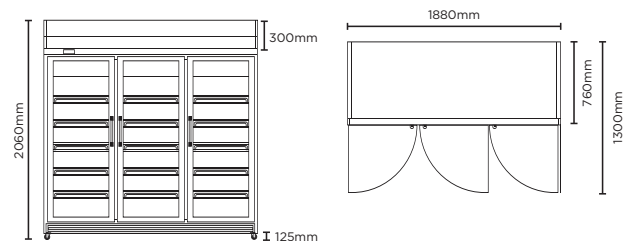

GD1500LF



Flat Glass Door 1507L LED Display Fridges

Part No.	Capacity	Weight
3736247	1507L	209kg

	External (mm)	Internal (mm)
Width	1880	1755
Depth	760	550
Height	2060	1420

- Double-glazed heated safety glass increases efficiency while reducing condensation
- Self-closing door with stay for easy stocking and hassle-free self service
- Temperature range: +2°C to +8°C

FF

Vertical Display & Storage

Upright Display Fridges

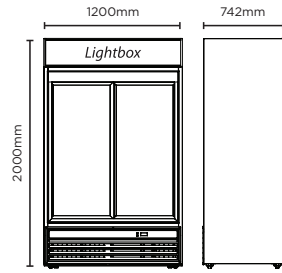

GM0980LS LED



Sliding Glass Door 945L LED Display Fridge

Part No.	Capacity	Weight
3735048	945L	210kg

- High-impact LED lighting and customizable lightbox capture attention
- Double-glazed safety glass increases efficiency while reducing condensation
- Self-closing door for hassle-free self service
- Illuminated light box to highlight branding
- Temperature range: +1°C to +10°C

	External (mm)	Internal (mm)
Width	1200	1090
Depth	742	572
Height	2000	1533

FF

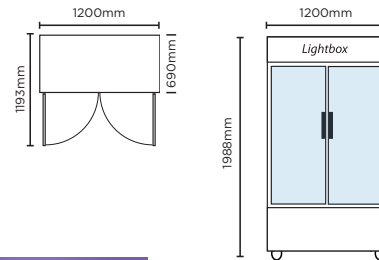

GM1000LW ECO



Flat Glass Door 960L LED Eco Beverage Display Fridge

Part No.	Capacity	Weight
3736252	960L	177kg

- Double-glazed heated safety glass increases efficiency while reducing condensation
- Adjustable shelving for flexibility in display configuration
- High-impact LED internal lighting
- Illuminated light box to highlight branding
- Temperature range: +1°C to +10°C

	External (mm)	Internal (mm)
Width	1200	1090
Depth	690	545
Height	1998	1707

FF

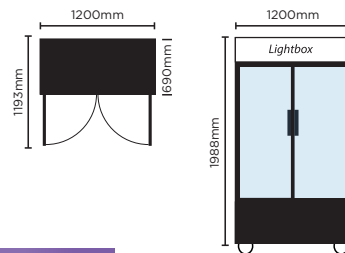

GM1000LB ECO



Flat Glass Door 960L LED Eco Beverage Display Fridge

Part No.	Capacity	Weight
3736253	960L	177kg

- Double-glazed heated safety glass increases efficiency while reducing condensation
- Adjustable shelving for flexibility in display configuration
- High-impact LED internal lighting
- Illuminated light box to highlight branding
- Temperature range: +1°C to +10°C

	External (mm)	Internal (mm)
Width	1200	1090
Depth	690	545
Height	1998	1707

FF



Vertical Display & Storage

Upright Display Fridges

REMOVABLE CASSETTE

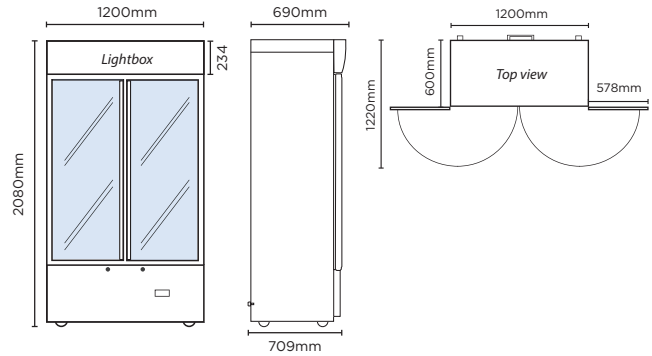

GM1000LBCAS

2 YEAR
EXTRA CARE
WARRANTY SERVICE

Cassette Flat Glass Door 960L LED Display Fridge

Part No. 3736251 Capacity 960L Weight 188kg

	External (mm)	Internal (mm)
Width	1200	1090
Depth	690	545
Height	2080	1465

- High-impact LED internal lighting on each side for perfect product presentation
- Heated air over door prevents condensation
- Fan forced for even temperature throughout the fridge
- Adjustable stabilising floor raisers
- Removable cassette refrigeration
- Temperature range: +2°C to +5°C

Green Cooling™

FF

REMOVABLE CASSETTE

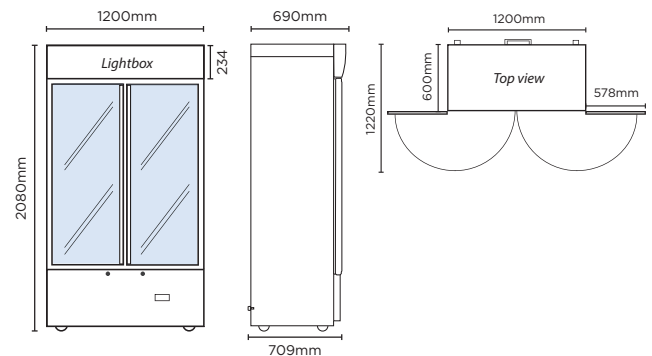

GM1000LWCAS

2 YEAR
EXTRA CARE
WARRANTY SERVICE

Cassette Flat Glass Door 960L LED Display Fridge

Part No. 3736250 Capacity 960L Weight 188kg

	External (mm)	Internal (mm)
Width	1200	1090
Depth	690	545
Height	2080	1465

- High-impact LED internal lighting on each side for perfect product presentation
- Heated air over door prevents condensation
- Fan forced for even temperature throughout the fridge
- Adjustable stabilising floor raisers
- Aluminium door frame
- Temperature range: +2°C to +5°C

Green Cooling™

FF

Vertical Display & Storage



“

Whether you need refrigeration to store products or display your merchandise, there is a Bromic solution for you.

”

Vertical Display & Storage

Upright Storage Fridges

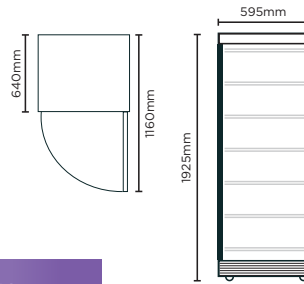

UC0374SDW



Solid Door 372L Storage Fridge

Part No.	Capacity	Weight
3735127	372L	88kg

	External (mm)	Internal (mm)
Width	595	505
Depth	640	462
Height	1925	1555

- Solid insulated coated steel door minimises heat ingress
- Reversible doors for complete flexibility
- Flexible storage with 6 adjustable shelves
- Temperature range: +1°C to +10°C

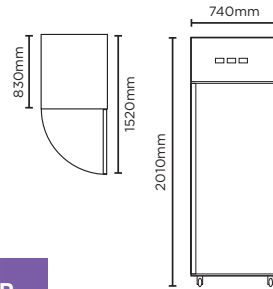

UC0650SD-NR



Gastronom Stainless Steel 650L Storage Fridge

Part No.	Capacity	Weight
3735161-NR	650L	143kg

	External (mm)	Internal (mm)
Width	740	624
Depth	830	685
Height	2010	1390

- Front lockable castors make movement and placement easy.
- Self-closing door provides hassle-free operation and energy efficiency.
- Supplied with stainless steel rails and 5 shelves for use with 2/1 Gastronom trays
- Dixell digital controller for precise temperature maintenance
- Temperature range: +1°C to +5°C

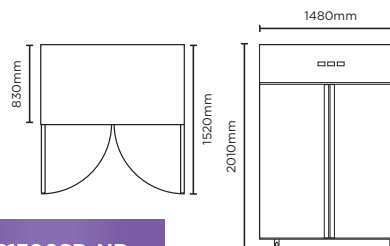

UC1300SD-NR



Gastronom Stainless Steel 1300L Storage Fridge

Part No.	Capacity	Weight
3735200-NR	1300L	213kg

	External (mm)	Internal (mm)
Width	1480	1360
Depth	830	685
Height	2010	1390

- Front lockable castors make movement and placement easy
- Self-closing door provides hassle-free operation and energy efficiency
- Supplied with stainless steel rails and 10 shelves for use with 2/1 Gastronom trays
- Dixell digital controller for precise temperature maintenance
- Temperature range: +1°C to +5°C

Vertical Display & Storage

Upright Display Freezers

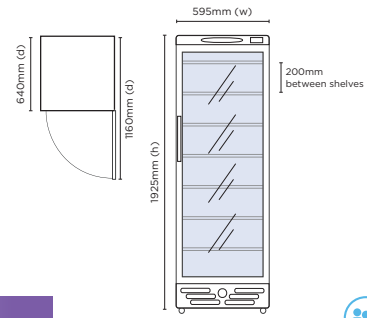

UF0374S LED



Flat Glass Door 300L LED Display Freezer

Part No.	Capacity	Weight
3736045	300L	102kg
	External (mm)	Internal (mm)
Width	595	475
Depth	640	440
Height	1925	1550

- High-impact LED lighting maximises product visibility and captures attention
- Self-closing door for hassle-free self service
- Refrigeration integrated into all 6 fixed shelves for even cooling
- Temperature range: -19°C to -14°C

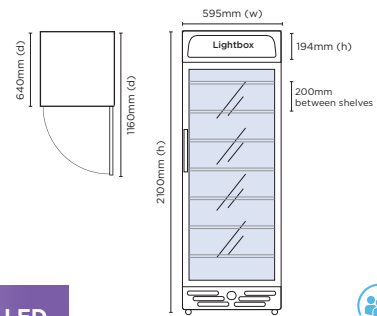

UF0374LS LED



Flat Glass Door 300L LED Display Freezer

Part No.	Capacity	Weight
3736046	300L	106kg
	External (mm)	Internal (mm)
Width	595	475
Depth	640	440
Height	2100	1550

- High-impact LED lighting and customizable lightbox capture attention
- Self-closing door for hassle-free self service
- Refrigeration integrated into all 6 fixed shelves for even cooling
- Temperature range: -19°C to -14°C

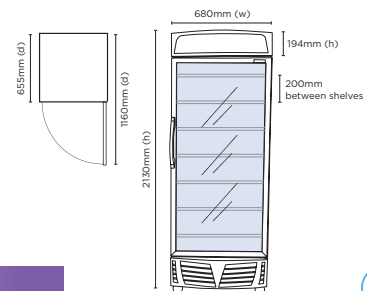

UF0440LS LED



Flat Glass Door 440L LED Display Freezer

Part No.	Capacity	Weight
3736047	440L	123kg
	External (mm)	Internal (mm)
Width	680	577
Depth	655	495
Height	2133	1510

- High-impact LED lighting and customizable lightbox capture attention
- Self-closing door for hassle-free self service
- Refrigeration integrated into all 6 fixed shelves for even cooling
- Temperature range: -19°C to -14°C

Vertical Display & Storage

Upright Display Freezers

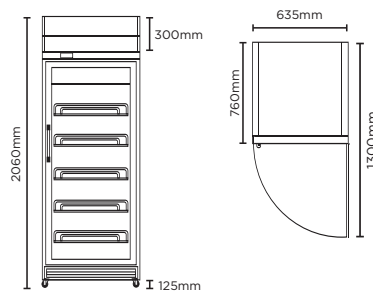

UF0500LF



Flat Glass Door 444L LED Display Freezer

Part No. 3736240 **Capacity** 444L **Weight** 113kg

	External (mm)	Internal (mm)
Width	635	520
Depth	760	550
Height	2060	1420

- Fan-forced refrigeration system
- Triple-glazed heated safety glass increases efficiency while reducing condensation
- Self-closing door with stay for easy stocking and hassle-free self service
- Temperature range: -22°C to -18°C

FF

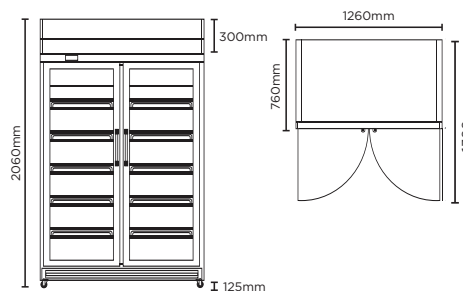

UF1000LF



Flat Glass Door 976L LED Display Freezer

Part No. 3736241 **Capacity** 976L **Weight** 199kg

	External (mm)	Internal (mm)
Width	1260	1143
Depth	760	550
Height	2060	1420

- Fan-forced refrigeration system
- Triple-glazed heated safety glass increases efficiency while reducing condensation
- Self-closing door with stay for easy stocking and hassle-free self service
- Temperature range: -22°C to -18°C

FF

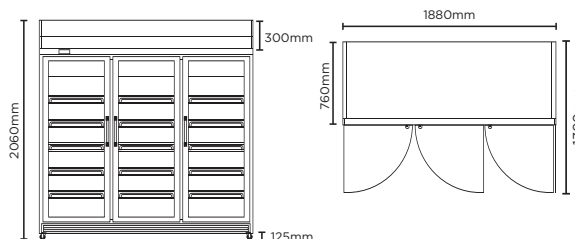

UF1500LF



Flat Glass Door 1507L LED Display Freezer

Part No. 3736242 **Capacity** 1507L **Weight** 279kg

	External (mm)	Internal (mm)
Width	1880	1755
Depth	760	550
Height	2060	1420

- Fan-forced refrigeration system
- Triple-glazed heated safety glass increases efficiency while reducing condensation
- Self-closing door with stay for easy stocking and hassle-free self service
- Temperature range: -22°C to -18°C

FF

Vertical Display & Storage

Upright Storage Freezers

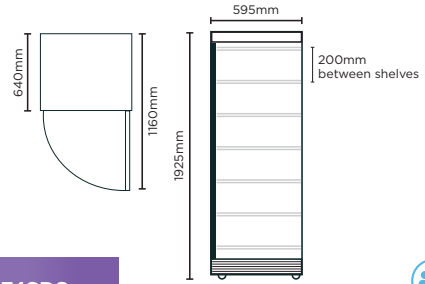

UF0374SDS

1 YEAR
EXTRA CARE
WARRANTY SERVICE

Solid Door 300L Storage Freezer

Part No. 3735106 **Capacity** 300L **Weight** 79.5kg

	External (mm)	Internal (mm)
Width	595	475
Depth	640	440
Height	1925	1550

- Lockable castors make movement and placement easy
- Solid insulated steel door minimises heat ingress
- Refrigeration integrated into all 6 fixed shelves for even cooling
- Temperature range: -19°C to -14°C

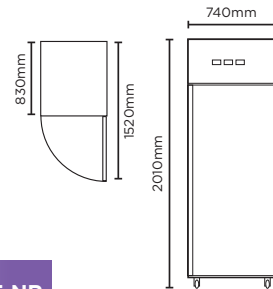

UF0650SDF-NR

2 YEAR
EXTRA CARE
WARRANTY SERVICE

Gastronom Stainless Steel 650L Storage Freezer

Part No. 3735203-NR **Capacity** 650L **Weight** 147kg

	External (mm)	Internal (mm)
Width	740	624
Depth	830	685
Height	2010	1390

- Lockable castors make movement and placement easy
- Self-closing door provides hassle-free operation and energy efficiency
- Supplied with stainless steel rails and 5 shelves for use with 2/1 Gastronom trays
- Dixell digital controller for precise temperature maintenance
- Temperature range: -22°C to -18°C

FF

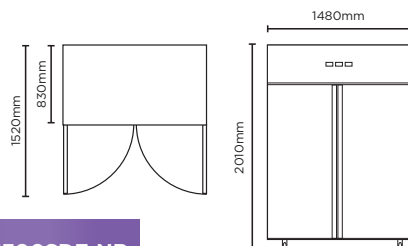

UF1300SDF-NR

2 YEAR
EXTRA CARE
WARRANTY SERVICE

Gastronom Stainless Steel 1300L Storage Freezer

Part No. 3735194-NR **Capacity** 1300L **Weight** 226kg

	External (mm)	Internal (mm)
Width	1480	1360
Depth	830	685
Height	2010	1390

- Lockable castors make movement and placement easy
- Self-closing door provides hassle-free operation and energy efficiency
- Supplied with stainless steel rails and 10 shelves for use with 2/1 Gastronom trays
- Dixell digital controller for precise temperature maintenance
- Temperature range: -22°C to -18°C

FF

Vertical Display & Storage

Specification Reference Guide

Fridge

Freezer

Model	GM0220 LED	GM0300 LED	GM0374 LED	GM0374L LED	GM0374LB LED
Part Number	3736033	3736034	3736035	3736036	3736092
Ext. Width (mm)*	595	595	595	595	595
Ext. Depth (mm)*	640	640	640	640	640
Ext. Height (mm)*	1400	1725	1950	2100	2100
Capacity	215L	290L	372L	372L	372L
Temp. Range	+1 to +10°C	+1 to +10°C	+1 to +10°C	+1 to +10°C	+1 to +10°C
Max. Ambient Temp.	40°C	40°C	40°C	40°C	40°C
Rated Power	235W	290W	350W	370W	370W
Current	2.0A	2.0A	2.6A	2.7A	2.7A
Gross Weight	68kg	74kg	81kg	85kg	85kg
Refrigerant	R134a	R134a	R134a	R134a	R134a
Plug Supplied	1	1	1	1	1
Power Supply	10A	10A	10A	10A	10A
Features					
Fridge Case	✓	✓	✓	✓	✓
Freezer Case					
Display Light Box				✓	✓
Main Light	LED	LED	LED	LED	LED
Door Shape	Flat	Flat	Flat	Flat	Flat
Safety Glass	✓	✓	✓	✓	✓
Door Lock					
No. of Doors	1	1	1	1	1
Self-Closing Door	✓	✓	✓	✓	✓
Temp. Controller	Analogue	Analogue	Analogue	Analogue	Analogue
Castors	✓	✓	✓	✓	✓
No. of Shelves Incl. Base Per Door	4	5	6	6	6
Colour	White with Silver Trim	White with Silver Trim	White with Silver Trim	White with Silver Trim	White with Black Details
Warranty					
Parts (Years)	1	1	1	1	1
Labour (Years)	1	1	1	1	1

*Depth dimensions exclude lightbox & handle protrusions

Vertical Display & Storage

Specification Reference Guide

Fridge

Freezer

Model	GM0400LC LED	GM0440L LED	GM0690LW	GM0690LB	GM1000LBCAS	GM1000LWCAS
Part Number	3736037	3736038	3736219	3736222	3736251	3736250
Ext. Width (mm)*	595	680	780	780	1200	1200
Ext. Depth (mm)*	640	655	705	705	690	690
Ext. Height (mm)*	2100	2125	2185	2185	2080	2080
Capacity	380L	438L	659L	659L	960L	960L
Temp. Range	+1 to +10°C	+1 to +10°C	+1 to +5°C	+1 to +5°C	+2 to +5°C	+2 to +5°C
Max. Ambient Temp.	40°C	40°C	43°C	43°C	38°C	38°C
Rated Power	370W	390W	485W	485W	520W	520W
Current	2.7A	3.3A	3.8A	3.8A	2.3A	2.3A
Gross Weight	90kg	110kg	123kg	123kg	188kg	188kg
Refrigerant	R134a	R134a	R290a	R290a	R290	R290
Plug Supplied	1	1	1	1	1	1
Power Supply	10A	10A	10A	10A	10A	10A
Features						
Fridge Case	✓	✓	✓	✓	✓	✓
Freezer Case						
Display Light Box	✓	✓	✓	✓	✓	✓
Main Light	LED	LED	LED	LED	LED	LED
Door Shape	Curved	Flat	Flat	Flat	Flat	Flat
Safety Glass	✓	✓	✓	✓	✓	✓
Door Lock					✓	✓
No. of Doors	1	1	1	1	2	2
Self-Closing Door	✓	✓	✓	✓	✓	✓
Temp. Controller	Analogue	Analogue	Digital	Digital	Digital	Digital
Castors	✓	✓	✓	✓	✓	✓
No. of Shelves Incl. Base Per Door	6	6	6	6	6	6
Colour	White with Silver Trim	White with Stainless Steel Details	White	Black	Black	White
Warranty						
Parts (Years)	1	1	1	1	2	2
Labour (Years)	1	1	1	1	2	2

*Depth dimensions exclude lightbox & handle protrusions

Vertical Display & Storage

Specification Reference Guide

Fridge

Freezer

Model	SPECIAL ORDER		SPECIAL ORDER			
	GM0300 RETRO	WC0400C LED	GM0690-VID	GDO500LF	GD1000LF	GD1500LF
Part Number	3736079	3735145	3736093	3736245	3736246	3736247
Ext. Width (mm)*	595	595	780	635	1260	1880
Ext. Depth (mm)*	610	640	705	760	760	760
Ext. Height (mm)*	1720	1840	2080	2060	2060	2060
Capacity	290L	372L	657L	444L	976L	1507L
Temp. Range	+1 to +10°C	+1 to +18°C	+1 to +10°C	+2 to +8°C	+2 to +8°C	+2 to +8°C
Max. Ambient Temp.	40°C	40°C	32°C	38°C	38°C	38°C
Rated Power	290W	270W	485W	740W	1000W	1132W
Current	2.0A	1.8A	3.8A	4.5A	5.6A	7.0A
Gross Weight	85kg	84kg	136kg	95kg	157kg	209kg
Refrigerant	R134a	R134a	R134a	R134a	R134a	R134a
Plug Supplied	1	1	1	1	1	1
Power Supply	10A	10A	10A	10A	10A	10A
Features						
Fridge Case	✓	✓	✓	✓	✓	✓
Freezer Case						
Display Light Box			✓	✓	✓	✓
Main Light	LED	LED	LED	LED	LED	LED
Door Shape	Flat	Curved	TV	Flat	Flat	Flat
Safety Glass	✓	✓	✓	✓	✓	✓
Door Lock				✓	✓	✓
No. of Doors	1	1	1	1	2	3
Self-Closing Door	✓	✓	✓	✓	✓	✓
Temp. Controller	Analogue	Analogue	Digital	Digital	Digital	Digital
Castors	✓	✓	✓	✓	✓	✓
No. of Shelves Incl. Base Per Door	5	6	5	6	6	6
Colour	Black/Custom	Silver	Custom	White with Stainless Steel Trim	White with Stainless Steel Trim	White with Stainless Steel Trim
Warranty						
Parts (Years)	1	1	1	1	1	1
Labour (Years)	1	1	1	1	1	1

*Depth dimensions exclude lightbox & handle protrusions

Vertical Display & Storage

Specification Reference Guide

Fridge

Freezer





Model	GM0980LS LED	GM1000LW ECO	GM1000LB ECO	UC0374SDW	UC0650SD-NR	UC1300SD-NR
Part Number	3735048	3736252	3736253	3735127	3735161-NR	3735200-NR
Ext. Width (mm)*	1200	1200	1200	595	740	1480
Ext. Depth (mm)*	742	690	690	640	830	830
Ext. Height (mm)*	2000	1998	1998	1925	2010	2010
Capacity	945L	960L	960L	372L	650L	1300L
Temp. Range	+1 to +10°C	+1 to +10°C	+1 to +10°C	+1 to +10°C	+1 to +5°C	+1 to +5°C
Max. Ambient Temp.	40°C	38°C	38°C	40°C	38°C	38°C
Rated Power	850W	650W	650W	350W	305W	508W
Current	5.8A	4A	4A	2.6A	3.0A	3.4A
Gross Weight	210kg	177kg	177kg	88kg	143kg	213kg
Refrigerant	R134a	R290	R290	R134a	R290	R290
Plug Supplied	1	1	1	1	1	1
Power Supply	10A	10A	10A	10A	10A	10A
Features						
Fridge Case	✓	✓	✓	✓	✓	✓
Freezer Case						
Display Light Box	✓	✓	✓			
Main Light	LED	LED	LED	Fluorescent	LED	LED
Door Shape	Flat	Flat	Flat	Flat	Flat	Flat
Safety Glass	✓	✓	✓			
Door Lock		✓	✓		✓	✓
No. of Doors	2	2	2	1	1	2
Self-Closing Door	✓	✓	✓	✓	✓	✓
Temp. Controller	Digital	Analogue	Analogue	Analogue	Digital	Digital
Castors		✓	✓	✓	✓	✓
No. of Shelves Incl. Base Per Door	5	5	5	7	6	6
Colour	Black	White	Black	White with Black Details	Stainless Steel	Stainless Steel
Warranty						
Parts (Years)	1	1	1	1	2	2
Labour (Years)	1	1	1	1	2	2

Vertical Display & Storage

Specification Reference Guide

Fridge

Freezer

Model	UF0374S LED 	UF0374LS LED 	UF0440LS LED 	UF0500LF 	UF1000LF 
Part Number	3736045	3736046	3736047	3736240	3736241
Ext. Width (mm)*	595	595	680	635	1260
Ext. Depth (mm)*	620	620	655	760	760
Ext. Height (mm)*	1925	2100	2133	2060	2060
Capacity	300L	300L	440L	444L	976L
Temp. Range	-19 to -14°C	-19 to -14°C	-19 to -14°C	-22 to -18°C	-22 to -18°C
Max. Ambient Temp.	35°C	35°C	35°C	38°C	38°C
Rated Power	620W	635W	867W	1000W	1600W
Current	3.9A	4.1A	5.6A	4.7A	8A
Gross Weight	102kg	106kg	123kg	113kg	199kg
Refrigerant	R404a	R404a	R404a	R404a	R404a
Plug Supplied	1	1	1	1	1
Power Supply	10A	10A	10A	10A	10A
Features					
Fridge Case					
Freezer Case	✓	✓	✓	✓	✓
Display Light Box		✓	✓	✓	✓
Main Light	LED	LED	LED	LED	LED
Door Shape	Flat	Flat	Flat	Flat	Flat
Safety Glass	✓	✓	✓	✓	✓
Door Lock				✓	✓
No. of Doors	1	1	1	1	2
Self-Closing Door	✓	✓	✓	✓	✓
Temp. Controller	Analogue	Analogue	Analogue	Digital	Digital
Castors	✓	✓	✓	✓	✓
No. of Shelves Incl. Base Per Door	7	7	7	6	6
Colour	White with Silver Trim	White with Silver Trim	White with Silver Trim	White with Stainless Steel Trim	White with Stainless Steel Trim
Warranty					
Parts (Years)	1	1	1	1	1
Labour (Years)	1	1	1	1	1

Vertical Display & Storage

Specification Reference Guide

Fridge

Freezer

Model	UF1500LF	UF0374SDS	UF0650SDF-NR	UF1300SDF-NR
Part Number	3736242	3735106	3735203-NR	3735194-NR
Ext. Width (mm)*	1880	595	740	1480
Ext. Depth (mm)*	760	640	830	830
Ext. Height (mm)*	2060	1925	2010	2010
Capacity	1507L	300L	650L	1300L
Temp. Range	-22 to -18°C	-19 to -14°C	-22 to -18°C	-22 to -18°C
Max. Ambient Temp.	38°C	35°C	38°C	38°C
Rated Power	2000W	270W	520W	815W
Current	9A	2.4A	4.2A	6.0A
Gross Weight	279kg	79.5kg	147kg	226kg
Refrigerant	R404a	R404a	R290	R290
Plug Supplied	1	1	1	1
Power Supply	15A	10A	10A	10A
Features				
Fridge Case				
Freezer Case	✓	✓	✓	✓
Display Light Box	✓			
Main Light	LED	Fluorescent	LED	LED
Door Shape	Flat	Flat	Flat	Flat
Safety Glass	✓			
Door Lock	✓		✓	✓
No. of Doors	3	1	1	2
Self-Closing Door	✓	✓	✓	✓
Temp. Controller	Digital	Analogue	Digital	Digital
Castors	✓	✓	✓	✓
No. of Shelves Incl. Base Per Door	6	7	6	6
Colour	White with Stainless Steel Trim	White with Black Details	Stainless Steel	Stainless Steel
Warranty				
Parts (Years)	1	1	2	2
Labour (Years)	1	1	2	2

Additional shelf extenders to prevent products from falling over

Designed specifically for seamless under-bench installation

Adjustable shelving for flexibility in display configuration

Side-mounted refrigeration maximises storage height and the removable dust filter simplifies maintenance (selected models only)



Castors (front lockable) make movement and placement easy

Curved internal corners simplify food-safe cleaning (stainless range only)

Stainless steel self-closing doors minimise temperature loss

High-impact LED lighting maximises product visibility and captures attention

Precise Dixell digital temperature controller for accurate temperature maintenance

Bromic's Bar Fridges & Freezers have been designed specifically for installation under an industry-standard bench and are available in one to four-door configurations.

33. Back Bar Display Fridges

Bromic's Back Bar Fridges are the perfect freestanding refrigerated display solution for those seeking versatility and reliability.

High-impact LED lighting highlights products through this unit's hinged or sliding double-glazed safety glass doors while powerful fan-forced refrigeration enables rapid cooling.



35. Underbench Display & Storage Fridges & Freezers

Bromic's Fan-Forced Underbench Fridges and Freezers are premium performers, developed specifically to withstand heavy use in the hospitality industry and to slot seamlessly underneath a industry-standard bench.

Featuring powerful fan-forced cooling, these units are capable of storing sensitive stock, such as meat, dairy or fresh produce, alongside beverages while also utilising Gastronorm 1/1 sizing to offer versatility in high-volume applications.

Display Fridge:



Storage Fridge:



Storage Freezer:



38. Single Door Underbench Display & Storage Fridges & Freezers

Bromic's Single Door Underbench Fridges and Freezers offer versatile storage solutions across a wide temperature range.

This unit's insulated stainless steel structure and Dixell digital temperature controller allow the refrigeration system to reliably cool practically any product while achieving exceptional energy efficiency.

Display Fridge:



Storage Fridge:



Storage Freezer:



39. Specification Reference Guide

Bar Fridges & Freezers

Back Bar Glass Door Display Fridges (Hinged Door)



Handle
Top to
Bottom

Full length door handle:

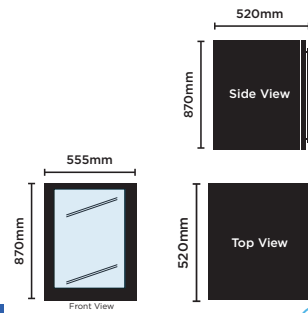

BB0120GD-NR

1 YEAR
EXTRA CARE
WARRANTY SERVICE

Back Bar Glass Door Display Fridge 118L (Hinged Door)

Part No. Capacity Weight
3736070-1 118L 58kg

	External (mm)	Internal (mm)
Width	555	520
Depth	520	385
Height	870	820

- High-impact LED lighting maximises product visibility
- Double-glazed safety glass increases efficiency while reducing condensation
- 2 adjustable shelves per door + base for optimal product display
- Temperature range: +1°C to +10°C
- Unit can be mounted high & door can still be opened
- Full length door handle
- Door cannot be reversed

FF

Green
Cooling.



Handle
Top to
Bottom

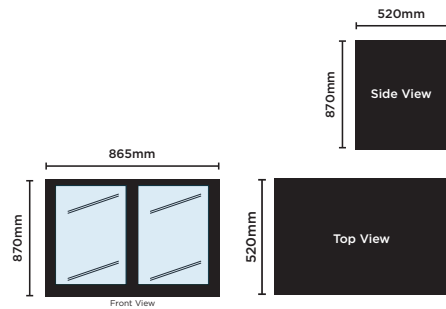

BB0200GD-NR

1 YEAR
EXTRA CARE
WARRANTY SERVICE

Back Bar Glass Door Display Fridge 190L (Hinged Door)

Part No. Capacity Weight
3736071-1 190L 72kg

	External (mm)	Internal (mm)
Width	865	820
Depth	520	385
Height	870	820

- High-impact LED lighting maximises product visibility
- Double-glazed safety glass increases efficiency while reducing condensation
- 2 adjustable shelves per door + base for optimal product display
- Temperature range: +1°C to +10°C
- Unit can be mounted high & door can still be opened

FF

Green
Cooling.



Handle
Top to
Bottom

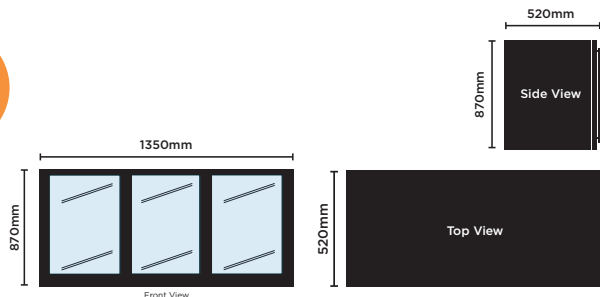

BB0330GD-NR

1 YEAR
EXTRA CARE
WARRANTY SERVICE

Back Bar Glass Door Display Fridge 307L (Hinged Door)

Part No. Capacity Weight
3736073-1 307L 90kg

	External (mm)	Internal (mm)
Width	1350	1270
Depth	520	385
Height	870	820

- High-impact LED lighting maximises product visibility
- Double-glazed safety glass increases efficiency while reducing condensation
- 2 adjustable shelves per door + base for optimal product display
- Temperature range: +1°C to +10°C
- Unit can be mounted high & door can still be opened

FF

Green
Cooling.

Bar Fridges & Freezers

Back Bar Glass Door Display Fridges (Sliding Door)

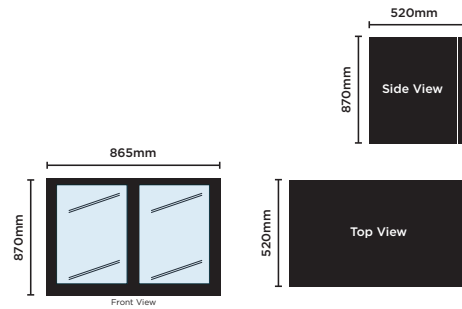

BB0200GDS-NR



Back Bar Display Fridge 190L (Sliding Door)

Part No. 3736072-1 **Capacity** 190L **Weight** 72kg

	External (mm)	Internal (mm)
Width	865	820
Depth	520	385
Height	870	820

- High-impact LED lighting maximises product visibility
- Double-glazed safety glass increases efficiency while reducing condensation
- 2 adjustable shelves per door + base for optimal product display
- Temperature range: +1°C to +10°C

FF

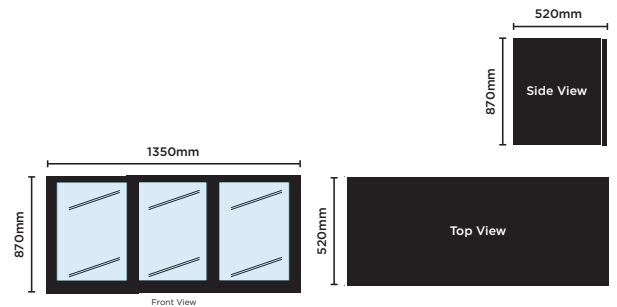

BB0330GDS-NR



Back Bar Display Fridge 307L (Sliding Door)

Part No. 3736074-1 **Capacity** 307L **Weight** 90kg

	External (mm)	Internal (mm)
Width	1350	1270
Depth	520	385
Height	870	820

- High-impact LED lighting maximises product visibility
- Double-glazed safety glass increases efficiency while reducing condensation
- 2 adjustable shelves per door + base for optimal product display
- Temperature range: +1°C to +10°C

FF



Bar Fridges & Freezers

Underbench Glass Door Display Fridges

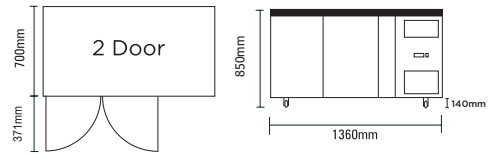

UBC1360GD-NR



Underbench Glass Door Display Fridge 282L LED

Part No.	Capacity	Weight
3735213-NR	282L	123kg

	External (mm)	Internal (mm)
Width	1360	902
Depth	700	530
Height	850	589

- Powerful fan-forced refrigeration cools cabinet evenly and quickly
- Side-mount condenser for easy maintenance
- Narrow spaced wires and shelf extenders to prevent bottles from falling over the shelf
- Temperature range: +1 to +5°C

FF

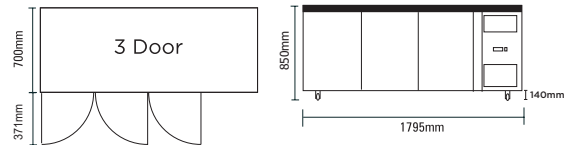

UBC1795GD-NR



Underbench Glass Door Display Fridge 417L LED

Part No.	Capacity	Weight
373521-NR	417L	162kg

	External (mm)	Internal (mm)
Width	1795	1337
Depth	700	530
Height	850	589

- Powerful fan-forced refrigeration cools cabinet evenly and quickly
- Side-mount condenser for easy maintenance
- Narrow spaced wires and shelf extenders to prevent bottles from falling over the shelf
- Temperature range: +1 to +5°C

FF

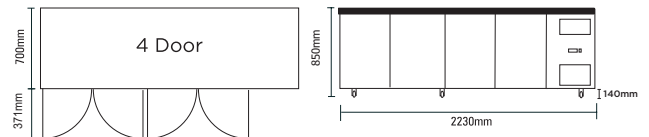

UBC2230GD-NR



Underbench Glass Door Display Fridge 553L LED

Part No.	Capacity	Weight
3735212-NR	553L	183kg

	External (mm)	Internal (mm)
Width	2230	1772
Depth	700	530
Height	850	589

- Powerful fan-forced refrigeration cools cabinet evenly and quickly
- Side-mount condenser for easy maintenance
- Narrow spaced wires and shelf extenders to prevent bottles from falling over the shelf
- Temperature range: +1 to +5°C

FF

Bar Fridges & Freezers

Underbench Storage Fridges

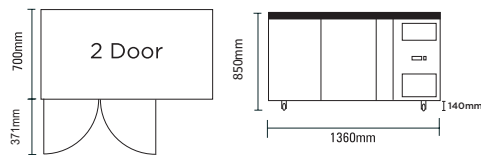

UBC1360SD-NR



Underbench Storage Fridge 282L

Part No.	Capacity	Weight
3735204-NR	282L	113kg
External (mm)		Internal (mm)
Width	1360	902
Depth	700	530
Height	850	589

- Powerful fan-forced refrigeration cools cabinet evenly and quickly
- Side-mount condenser for easy maintenance
- Narrow spaced wires and shelf extenders to prevent bottles from falling over the shelf
- Temperature range: +1 to +5°C

FF

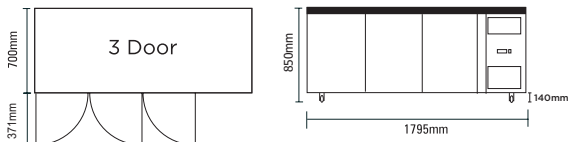

UBC1795SD-NR



Underbench Storage Fridge 417L

Part No.	Capacity	Weight
3735206-NR	417L	152kg
External (mm)		Internal (mm)
Width	1795	1337
Depth	700	530
Height	850	589

- Powerful fan-forced refrigeration cools cabinet evenly and quickly
- Side-mount condenser for easy maintenance
- Narrow spaced wires and shelf extenders to prevent bottles from falling over the shelf
- Temperature range: +1 to +5°C

FF

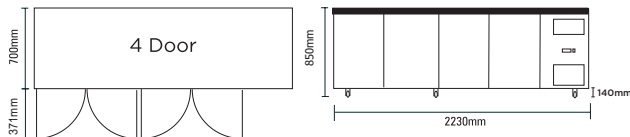

UBC2230SD-NR



Underbench Storage Fridge 553L

Part No.	Capacity	Weight
3735209-NR	553L	173kg
External (mm)		Internal (mm)
Width	2230	1772
Depth	700	530
Height	850	589

- Powerful fan-forced refrigeration cools cabinet evenly and quickly
- Side-mount condenser for easy maintenance
- Narrow spaced wires and shelf extenders to prevent bottles from falling over the shelf
- Temperature range: +1 to +5°C

FF

Bar Fridges & Freezers

Underbench Storage Freezers

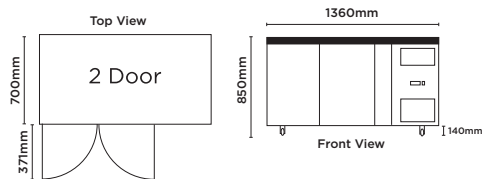

UBF1360SD-NR



Underbench Storage Freezer 282L

Part No. 3736230-NR
Capacity 282L
Weight 103kg

	External (mm)	Internal (mm)
Width	1360	902
Depth	700	530
Height	850	589

- Powerful fan-forced refrigeration cools cabinet evenly and quickly
- Side-mount condenser for easy maintenance
- Narrow spaced wires and shelf extenders to prevent bottles from falling over the shelf
- Temperature range: -22°C to -18°C

FF

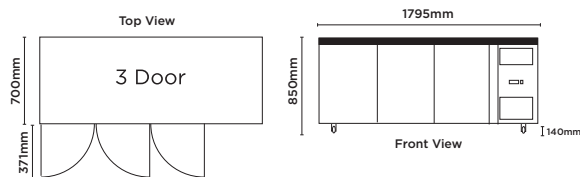

UBF1795SD-NR



Underbench Storage Freezer 417L

Part No. 3736231-NR
Capacity 417L
Weight 154kg

	External (mm)	Internal (mm)
Width	1795	1337
Depth	700	530
Height	850	589

- Powerful fan-forced refrigeration cools cabinet evenly and quickly
- Side-mount condenser for easy maintenance
- Narrow spaced wires and shelf extenders to prevent bottles from falling over the shelf
- Temperature range: -22°C to -18°C

FF

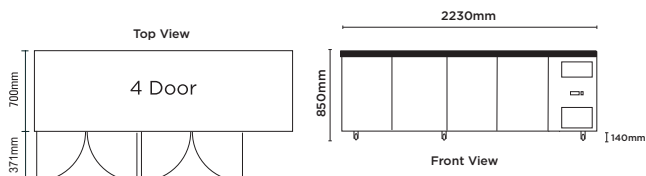

UBF2230SD-NR



Underbench Storage Freezer 553L

Part No. 3736232-NR
Capacity 553L
Weight 175kg

	External (mm)	Internal (mm)
Width	2230	1772
Depth	700	530
Height	850	589

- Powerful fan-forced refrigeration cools cabinet evenly and quickly
- Side-mount condenser for easy maintenance
- Narrow spaced wires and shelf extenders to prevent bottles from falling over the shelf
- Temperature range: -22°C to -18°C

FF

Bar Fridges & Freezers

Underbench Single Door Fridges & Freezer



Full Stainless Steel Exterior

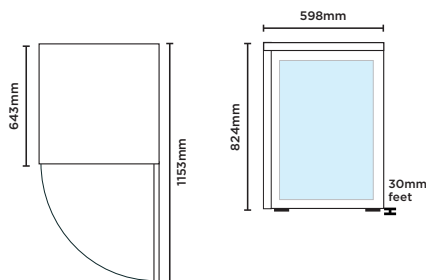

UBC0140GD-NR



Underbench Display Chiller 138L

Part No.	Capacity	Weight
3736255	138L	45kg

- Easily stackable with other Bromic single door units
- Reversible hinge for flexible installation options
- Door lock to secure stock
- Adjustable 30mm feet and back rollers
- 3 adjustable shelves + base
- Stainless steel top and door frame
- Temperature range: +1°C to +10°C

	External (mm)	Internal (mm)
Width	598	490
Depth	643	400
Height	824	680



Full Stainless Steel Exterior

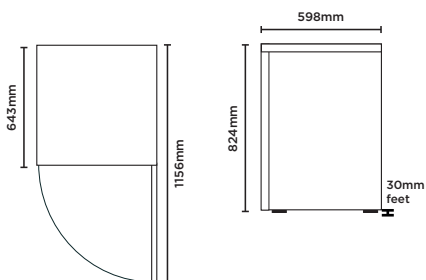

UBC0140SD-NR



Underbench Storage Fridge 138L

Part No.	Capacity	Weight
3736254	138L	36kg

- Easily stackable with other Bromic single door units
- Reversible hinge for flexible installation options
- Door lock to secure stock
- Adjustable 30mm feet and back rollers
- 3 adjustable shelves
- Stainless steel top and door frame
- Temperature range: +1°C to +10°C

	External (mm)	Internal (mm)
Width	598	490
Depth	643	400
Height	824	680



Full Stainless Steel Exterior

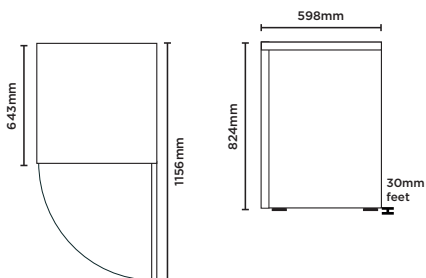

UBF0140SD-NR



Underbench Storage Freezer 115L

Part No.	Capacity	Weight
3736256	115L	38kg

- Easily stackable with other Bromic single door units
- Reversible hinge for flexible installation options
- Door lock to secure stock
- Adjustable 30mm feet and back rollers
- 3 baskets with static cooling inbetween
- Stainless steel top and door frame
- Temperature range: -24°C to -16°C

	External (mm)	Internal (mm)
Width	598	490
Depth	643	400
Height	824	680



Bar Fridges & Freezers

Specification Reference Guide

Fridge

Freezer

Model	BB0120GD-NR	BB0200GD-NR	BB0330GD-NR	BB0200GDS-NR	BB0330GDS-NR
Part Number	3736070-1	3736071-1	3736073-1	3736072-1	3736074-1
Ext. Width (mm)*	555	865	1350	865	1350
Ext. Depth (mm)*	520	520	520	520	520
Ext. Height (mm)*	870	870	870	870	870
Capacity	118L	190L	307L	190L	307L
Temp. Range	+1 to +10°C	+1 to +10°C	+1 to +10°C	+1 to +10°C	+1 to +10°C
Max. Ambient Temp.	38°C	38°C	38°C	38°C	38°C
Rated Power	182W	213W	408W	213W	408W
Current	0.95A	1.2A	2.1A	1.2A	2.1A
Gross Weight	58kg	72kg	90kg	72kg	90kg
Refrigerant	R600	R600	R600	R600	R600
Plug Supplied	1	1	1	1	1
Power Supply	10A	10A	10A	10A	10A
Features					
Chiller Case	✓	✓	✓	✓	✓
Freezer Case					
Main Light	LED	LED	LED	LED	LED
Number of Doors	1	2	3	2	3
Door Type	Hinged	Hinged	Hinged	Sliding	Sliding
Safety Glass	✓	✓	✓	✓	✓
Door Lock	✓	✓	✓	✓	✓
Temp. Controller	Digital	Digital	Digital	Digital	Digital
Feet / Castors	✓	✓	✓	✓	✓
No. of Shelves Incl. Base	3	3	3	3	3
Shelves with Narrow Spaced Wires	✓	✓	✓	✓	✓
Colour	Black	Black	Black	Black	Black
Warranty					
Parts (Years)	1	1	1	1	1
Labour (Years)	1	1	1	1	1

*Dimensions exclude lightbox & handle protrusions

Bar Fridges & Freezers

Specification Reference Guide

Fridge

Freezer

Model	UBC1360GD-NR	UBC1795GD-NR	UBC2230GD-NR	UBC1360SD-NR	UBC1795SD-NR	UBC2230SD-NR
Part Number	3735213-NR	3735211-NR	3735212-NR	3735204-NR	3735206-NR	3735209-NR
Ext. Width (mm)*	1360	1795	2230	1360	1795	2230
Ext. Depth (mm)*	700	700	700	700	700	700
Ext. Height (mm)*	850	850	850	850	850	850
Capacity	282L	417L	553L	282L	417L	553L
Temp. Range	+1 to +5°C	+1 to +5°C	+1 to +5°C	+1 to +5°C	+1 to +5°C	+1 to +5°C
Max. Ambient Temp.	32°C	32°C	32°C	38°C	38°C	38°C
Rated Power	275W	275W	398W	275W	275W	398W
Current	2.0A	2.0A	2.7A	2.0A	2.0A	2.7A
Gross Weight	123kg	162kg	183kg	113kg	152kg	173kg
Refrigerant	R600a	R600a	R290	R600a	R600a	R290
Plug Supplied	1	1	1	1	1	1
Power Supply	10A	10A	10A	10A	10A	10A
Features						
Chiller Case	✓	✓	✓	✓	✓	✓
Freezer Case						
Main Light	LED	LED	LED			
Number of Doors	2	3	4	2	3	4
Door Type	Hinged	Hinged	Hinged	Hinged	Hinged	Hinged
Safety Glass	✓	✓	✓			
Door Lock						
Temp. Controller	Digital	Digital	Digital	Digital	Digital	Digital
Feet / Castors	✓	✓	✓	✓	✓	✓
No. of Shelves Incl. Base	3x2	3x3	3x4	3x2	3x3	3x4
Shelves with Narrow Spaced Wires	✓	✓	✓	✓	✓	✓
Colour	Stainless Steel	Stainless Steel	Stainless Steel	Stainless Steel	Stainless Steel	Stainless Steel
Warranty						
Parts (Years)	2	2	2	2	2	2
Labour (Years)	2	2	2	2	2	2



*Dimensions exclude lightbox & handle protrusions

Bar Fridges & Freezers

Specification Reference Guide

Fridge

Freezer

Model	UBF1360SD-NR 	UBF1795SD-NR 	UBF2230SD-NR 
Part Number	3736230-NR	3736231-NR	3736232-NR
Ext. Width (mm)*	1360	1795	2230
Ext. Depth (mm)*	700	700	700
Ext. Height (mm)*	850	850	850
Capacity	282L	417L	553L
Temp. Range	-22 to -18°C	-22 to -18°C	-22 to -18°C
Max. Ambient Temp.	38°C	38°C	38°C
Rated Power	675W	675W	675W
Current	4.5A	4.5A	4.5A
Gross Weight	103kg	154kg	175kg
Refrigerant	R290	R290	R290
Plug Supplied	1	1	1
Power Supply	10A	10A	10A
Features			
Chiller Case			
Freezer Case	✓	✓	✓
Main Light			
Number of Doors	2	3	4
Door Type	Hinged	Hinged	Hinged
Safety Glass			
Door Lock			
Temp. Controller	Digital	Digital	Digital
Feet / Castors	✓	✓	✓
No. of Shelves Incl. Base	3 x 2	3 x 3	3 x 4
Shelves with Narrow Spaced Wires	✓	✓	✓
Colour	Stainless Steel	Stainless Steel	Stainless Steel
Warranty			
Parts (Years)	2	2	2
Labour (Years)	2	2	2

*Dimensions exclude lightbox & handle protrusions

These units are classified as storage cabinets and designed for holding foodstuffs which require some preparation or processing before sale

Bar Fridges & Freezers

Specification Reference Guide

Fridge

Freezer

Model	UBC0140GD-NR	UBC0140SD-NR	UBF0140SD-NR 
Part Number	3736255	3736254	3736256
Ext. Width (mm)*	598	598	598
Ext. Depth (mm)*	643	643	643
Ext. Height (mm)*	824	824	824
Capacity	138L	138L	115L
Temp. Range	+1 to +10°C	+1 to +10°C	-24 to -16°C
Max. Ambient Temp.	32°C	32°C	32°C
Rated Power	100W	100W	100W
Current	1.2A	1.2A	1.2A
Gross Weight	45kg	36kg	38kg
Refrigerant	R600a	R600a	R600a
Plug Supplied	1	1	1
Power Supply	10A	10A	10A
Features			
Chiller Case	✓	✓	
Freezer Case			✓
Main Light	LED		
Number of Doors	1	1	1
Door Type	Hinged (S/Steel)	Hinged (S/Steel)	Hinged (S/Steel)
Safety Glass	✓		
Door Lock	✓	✓	✓
Temp. Controller	Digital	Digital	Digital
Feet / Castors	✓	✓	✓
No. of Shelves Incl. Base	4	4	3 Baskets
Shelves with Narrow Spaced Wires	✓	✓	
Colour	Stainless Steel	Stainless Steel	Stainless Steel
Warranty			
Parts (Years)	1	1	1
Labour (Years)	1	1	1

*Dimensions exclude lightbox & handle protrusions

These units are classified as storage cabinets and designed for holding foodstuffs which require some preparation or processing before sale



Tempered glass or stainless steel lid offer storage and display flexibility

High load limit maximises storage

Perfect seal for energy efficiency

Integrated lock and key secures merchandise

Fully populated with durable PVC-coated storage baskets (glass top only)

Quick-drain plug simplifies defrost and cleaning

Castors make movement & placement easy

2m lead and 10A plug included for simple plug-in installation

Corrosion-resistant construction provides longevity

Digital temperature display enables quick quality control

Bromic's European-built Chest Freezers offer a reliable and economical freezer solution. Available with lid options to suit various applications, such as display, storage, or for an additional workspace.

45. Angled Glass Top Chest Freezer

Bromic's Angled Glass Top Chest Freezers prioritise product visibility by tilting its curved glass top towards customers.

These units feature easy-clean condensers and double glazed glass lids to keep condensation to a minimum in the harshest Australian conditions.



46. Flat Glass Top Chest Freezer

Bromic's Flat Top Chest Freezers offer versatility in frozen storage and retail display across a wide capacity range (191L-670L).

Supplied completely populated with PVC-coated storage baskets, these units feature easy-clean condensers and double glazed glass lids to keep condensation to a minimum in the harshest Australian conditions.



47. Flat Stainless Steel Top Chest Freezer

Bromic's Flat Stainless Steel Top Chest Freezers are designed to provide a workspace and deep-freeze storage solution all-in-one.

Suitable for storing fresh produce, such as meat or vegetables, for long periods at as low as -25°C, even when in ambient temperatures as high as 35°C. These units are perfect for maximising bench space while minimising wastage.



48. Specification Reference Guide

CHEST FREEZERS

Chest Freezers

Display Chest Freezers

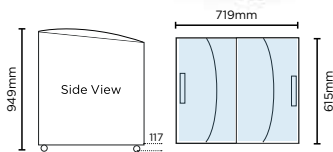

CF0200ATCG



Angled Glass Top 176L Chest Freezer

Part No.	Capacity	Weight
3735301	176L	57kg

	External (mm)	Internal (mm)
Width	719	600
Depth	615	495
Height	949	708

- Smooth curved sliding glass lids in aluminium top frame with integrated lock
- Lockable front castors make movement and placement easy
- 2 display baskets included
- Temperature range: -22°C to -12°C

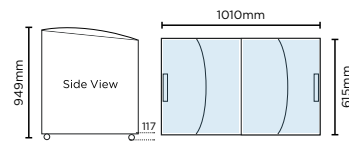

CF0300ATCG



Angled Glass Top 264L Chest Freezer

Part No.	Capacity	Weight
3735302	264L	70kg

	External (mm)	Internal (mm)
Width	1010	890
Depth	615	495
Height	949	708

- Smooth curved sliding glass lids in aluminium top frame with integrated lock
- Lockable front castors make movement and placement easy
- 4 display baskets included
- Temperature range: -22°C to -12°C

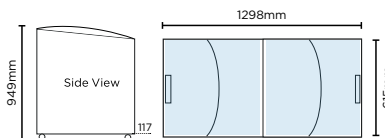

CF0400ATCG



Angled Glass Top 352L Chest Freezer

Part No.	Capacity	Weight
3735303	352L	81kg

	External (mm)	Internal (mm)
Width	1298	1180
Depth	615	495
Height	949	708

- Smooth curved sliding glass lids in aluminium top frame with integrated lock
- Lockable front castors make movement and placement easy.
- 5 display baskets included
- Temperature range: -22°C to -12°C
- Capacity is 352L

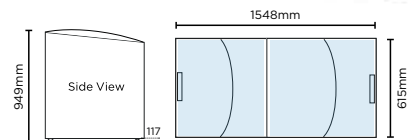

CF0500ATCG



Angled Glass Top 427L Chest Freezer

Part No.	Capacity	Weight
3736203	427L	96kg

	External (mm)	Internal (mm)
Width	1548	1430
Depth	615	495
Height	949	708

- Smooth curved sliding glass lids in aluminium top frame with integrated lock
- Lockable front castors make movement and placement easy
- 6 display baskets included
- Temperature range: -22°C to -12°C

Chest Freezers

Display Chest Freezers

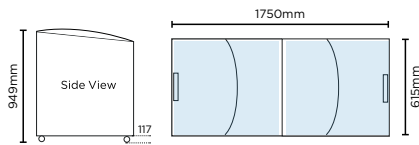

CF0600ATCG



Angled Glass Top 555L Chest Freezer

Part No.	Capacity	Weight
3736204	555L	114kg

	External (mm)	Internal (mm)
Width	1750	1630
Depth	615	495
Height	949	708

- Smooth curved sliding glass lids in aluminium top frame with integrated lock
- Lockable front castors make movement and placement easy
- 6 display baskets included
- Temperature range: -22°C to -12°C

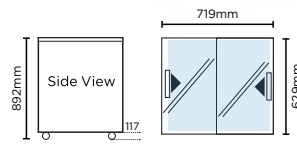

CF0200FTFG



Flat Glass Top 191L Chest Freezer

Part No.	Capacity	Weight
3735308	191L	58kg

	External (mm)	Internal (mm)
Width	719	600
Depth	629	510
Height	892	663

- Smooth sliding glass lids in aluminium top frame with integrated lock
- Lockable front castors make movement and placement easy
- 2 display baskets included
- Temperature range: -22°C to -12°C

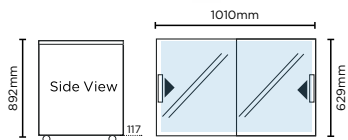

CF0300FTFG



Flat Glass Top 296L Chest Freezer

Part No.	Capacity	Weight
3735309	296L	70kg

	External (mm)	Internal (mm)
Width	1010	890
Depth	629	510
Height	892	663

- Smooth sliding glass lids in aluminium top frame with integrated lock
- Lockable front castors make movement and placement easy
- 4 display baskets included
- Temperature range: -22°C to -12°C

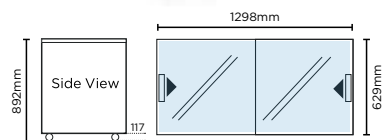

CF0400FTFG



Flat Glass Top 401L Chest Freezer

Part No.	Capacity	Weight
3735310	401L	80kg

	External (mm)	Internal (mm)
Width	1298	1180
Depth	629	510
Height	892	663

- Smooth sliding glass lids on aluminium top frame with integrated lock
- Lockable front castors make movement and placement easy
- 5 display baskets included
- Temperature range: -22°C to -12°C

Chest Freezers

Display & Storage Chest Freezers

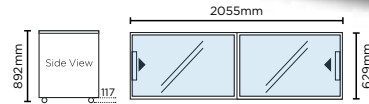
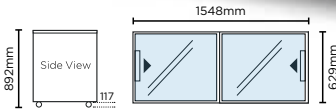

CF0500FTFG



Flat Glass Top 491L Chest Freezer

Part No.	Capacity	Weight
3735304	491L	101kg

	External (mm)	Internal (mm)
Width	1548	1430
Depth	629	510
Height	892	663

- Smooth sliding glass lids on aluminium top frame with integrated lock
- Lockable front castors make movement and placement easy
- 6 display baskets included
- Temperature range: -22°C to -12°C

CF0700FTFG



Flat Glass Top 670L Chest Freezer

Part No.	Capacity	Weight
3735305	670L	120kg

	External (mm)	Internal (mm)
Width	2055	1930
Depth	629	510
Height	892	663

- Smooth sliding glass lids on aluminium top frame with integrated lock
- Lockable front castors make movement and placement easy
- 8 display baskets included
- Temperature range: -22°C to -12°C

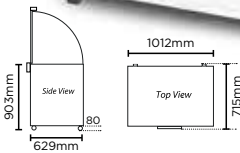

Stainless Steel Lid

CF0300FTSS



Flat Top Stainless Steel 296L Chest Freezer

Part No.	Capacity	Weight
3735312	296L	65kg

	External (mm)	Internal (mm)
Width	1012	890
Depth	715	510
Height	903	682

- Ideal deep-freeze storage solution
- Easy-lift, 80mm dual-hinged stainless steel lids with integrated lock
- Lockable front castors make movement and placement easy
- 1 storage basket included
- Temperature range: -25°C to -15°C

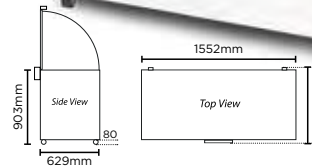

Stainless Steel Lid

CF0500FTSS



Flat Top Stainless Steel 492L Chest Freezer

Part No.	Capacity	Weight
3735307	492L	94kg

	External (mm)	Internal (mm)
Width	1552	1430
Depth	715	510
Height	903	682

- Ideal deep-freeze storage solution
- Easy-lift, 80mm dual-hinged stainless steel lids with integrated lock
- Lockable front castors make movement and placement easy
- 2 storage baskets included
- Temperature range: -25°C to -15°C



Stainless Steel Lid

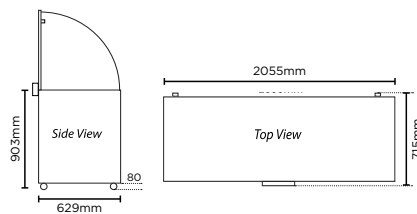

CF0700FTSS



Flat Top Stainless Steel 675L Chest Freezer





Part No.	Capacity	Weight
3735306	675L	119kg

	External (mm)	Internal (mm)
Width	2055	1935
Depth	715	510
Height	903	682

- Ideal deep-freeze storage solution
- Easy-lift, 80mm dual-hinged stainless steel lids with integrated lock
- Lockable front castors make movement and placement easy
- 3 storage baskets included
- Temperature range: -25°C to -15°C

Chest Freezers





Specification Reference Guide

Model	CF0200ATCG 	CF0300ATCG 	CF0400ATCG 	CF0500ATCG 
Part Number	3735301	3735302	3735303	3736203
Ext. Width (mm)*	719	1010	1298	1548
Ext. Depth (mm)*	615	615	615	615
Ext. Height (mm)*	949	949	949	949
Capacity	176L	264L	352L	427L
Temp. Range	-22 to -12°C	-22 to -12°C	-22 to -12°C	-22 to -12°C
Max. Ambient Temp.	35°C	35°C	35°C	35°C
Rated Power	190W	220W	300W	400W
Current	1.5A	1.9A	2.3A	2.6A
Gross Weight	57kg	70kg	81kg	96kg
Refrigerant	R404a	R404a	R404a	R404a
Plug Supplied	1	1	1	1
Power Supply	10A	10A	10A	10A
Features				
Main Light				
No. of Lids	2	2	2	2
Lid Type	Slide	Slide	Slide	Slide
Lid Shape	Curved	Curved	Curved	Curved
Safety Glass Lid	✓	✓	✓	✓
Stainless Steel Lid				
Door Lock	✓	✓	✓	✓
Temp. Display	LCD	LCD	LCD	LCD
Lockable Front Castors	✓	✓	✓	✓
No. of Baskets	2	4	5	6
Colour	White	White	White	White
Warranty				
Parts (Years)	2	2	2	2
Labour (Years)	2	2	2	2

*Dimensions exclude handle protrusions





Chest Freezers

Display & Storage Chest Freezers

Model	CF0600ATCG 	CF0200FTFG 	CF0300FTFG 	CF0400FTFG 	CF0500FTFG 
Part Number	3736204	3735308	3735309	3735310	3735304
Ext. Width (mm)*	1750	719	1010	1298	1548
Ext. Depth (mm)*	615	629	629	629	629
Ext. Height (mm)*	949	892	892	892	892
Capacity	555L	191L	296L	401L	491L
Temp. Range	-22 to -12°C	-22 to -12°C	-22 to -12°C	-22 to -12°C	-22 to -12°C
Max. Ambient Temp.	35°C	35°C	35°C	35°C	35°C
Rated Power	420W	190W	220W	300W	400W
Current	2.75A	1.5A	1.9A	2.3A	2.6A
Gross Weight	114kg	58kg	70kg	80kg	101kg
Refrigerant	R404a	R404a	R404a	R404a	R404a
Plug Supplied	1	1	1	1	1
Power Supply	10A	10A	10A	10A	10A
Features					
Main Light					
No. of Lids	2	2	2	2	2
Lid Type	Slide	Slide	Slide	Slide	Slide
Lid Shape	Curved	Flat	Flat	Flat	Flat
Safety Glass Lid	✓	✓	✓	✓	✓
Stainless Steel Lid					
Door Lock	✓	✓	✓	✓	✓
Temp. Display	LCD	LCD	LCD	LCD	LCD
Lockable Front Castors	✓	✓	✓	✓	✓
No. of Baskets	6	2	4	5	6
Colour	White	White	White	White	White
Warranty					
Parts (Years)	2	2	2	2	2
Labour (Years)	2	2	2	2	2

Chest Freezers

Specification Reference Guide

Model	CF0700FTFG 	CF0300FTSS 	CF0500FTSS 	CF0700FTSS 
Part Number	3735305	3735312	3735307	3735306
Ext. Width (mm)*	2055	1012	1552	2055
Ext. Depth (mm)*	629	715	715	715
Ext. Height (mm)*	892	903	903	903
Capacity	670L	296L	492L	675L
Temp. Range	-22 to -12°C	-25 to -15°C	-25 to -15°C	-25 to -15°C
Max. Ambient Temp.	35°C	35°C	35°C	35°C
Rated Power	440W	175W	400W	425W
Current	2.9A	1.2A	2.6A	2.9A
Gross Weight	120kg	65kg	94kg	119kg
Refrigerant	R404a	R404a	R404a	R404a
Plug Supplied	1	1	1	1
Power Supply	10A	10A	10A	10A
Features				
Main Light		✓	✓	
No. of Lids	2	1	1	1
Lid Type	Slide	Hinged	Hinged	Hinged
Lid Shape	Flat	Flat	Flat	Flat
Safety Glass Lid	✓			
Stainless Steel Lid		✓	✓	✓
Door Lock	✓	✓	✓	✓
Temp. Display	LCD	LCD	LCD	LCD
Lockable Front Castors	✓	✓	✓	✓
No. of Baskets	8	1	2	3
Colour	White	White	White	White
Warranty				
Parts (Years)	2	2	2	2
Labour (Years)	2	2	2	2

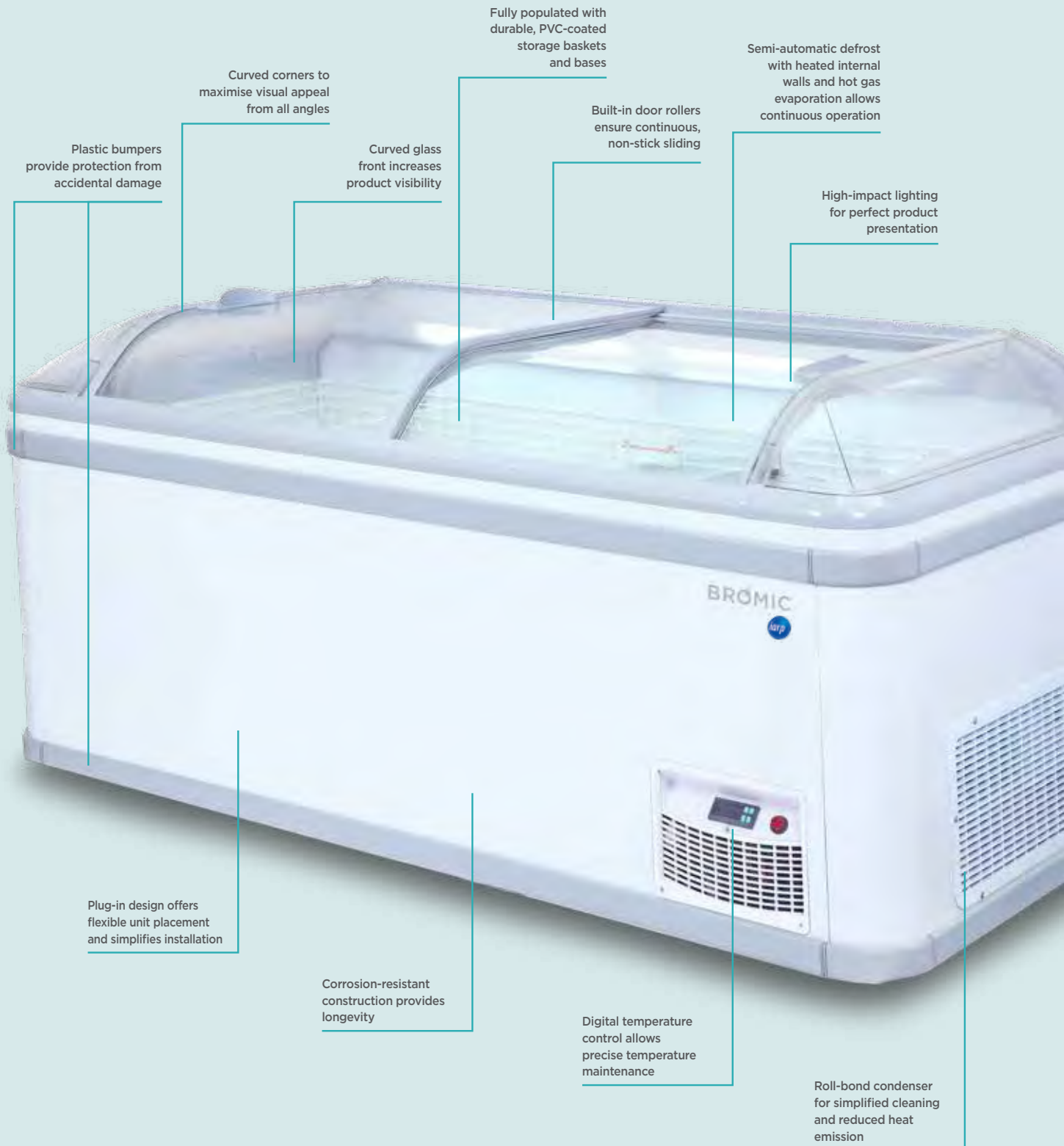

Plastic bumpers provide protection from accidental damage

Curved corners to maximise visual appeal from all angles

Curved glass front increases product visibility

Fully populated with durable, PVC-coated storage baskets and bases

Built-in door rollers ensure continuous, non-stick sliding

Semi-automatic defrost with heated internal walls and hot gas evaporation allows continuous operation

High-impact lighting for perfect product presentation

Plug-in design offers flexible unit placement and simplifies installation

Corrosion-resistant construction provides longevity

Digital temperature control allows precise temperature maintenance

Roll-bond condenser for simplified cleaning and reduced heat emission



Bromic's IRENE Island Freezers provide the perfect plug-in frozen display solution, creating seamless island displays that emit minimal heat and feature semi-automatic defrost functionality.

53. Irene ECO Supermarket Freezer

Bromic's Irene ECO Supermarket Freezers have been researched and developed in-house in conjunction with internationally-acclaimed manufacturer IARP to create the perfect standalone frozen display solution.

Eliminating expensive installation, these exceptionally-built self-contained units combine to create impressive island or wall displays that are simply powered using 10A plugs.



Optional Extras

Bromic Irene ECO Panel Kit

Bromic's Irene ECO Panel Kits enable seamless connection of multiple units to create a single island display, filling gaps at the top (35160130003) and sides (35160130001) while retaining necessary airflow.

54. Specification Reference Guide

PROFESSIONAL RANGE

Island Configuration:



Accessories	TOP PANEL KIT EXT 250 IRENE	SIDE PANEL KIT
Part Number	35160130003	35160130001
Description	Flat top panel 250 mm kit Extension 400mm (2 x Panel Supports + 1 x Top Panel) for IRENE ECO 250	Flat Side panel for IRENE ECO 250

Island Freezers

PROFESSIONAL RANGE

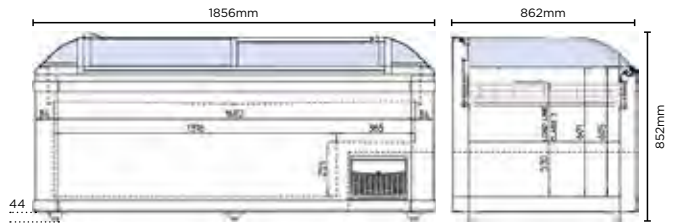

Base & Basket Layout

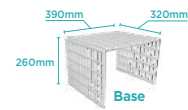
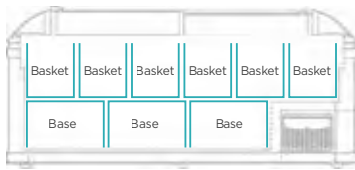

IRENE ECO 185

SPECIAL ORDER



Irene ECO 1856mm Island Freezer End Cabinet

Part No. 3735319 Capacity 805/525L Weight 161kg

	External (mm)	Internal (mm)
Width	1856	1682
Depth	862	702
Height	852	753

- Curved double-glazed lid offers exceptional product visibility for children and adults alike
- Roll-bond condenser simplifies cleaning, reduces heat emission and saves space
- Temperature range: -25°C to -18°C

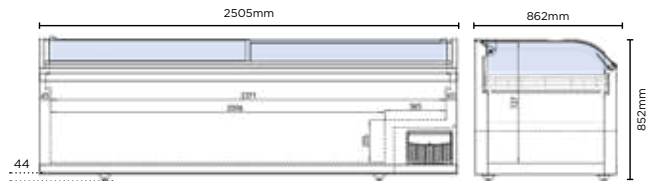

Base & Basket Layout

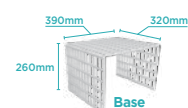
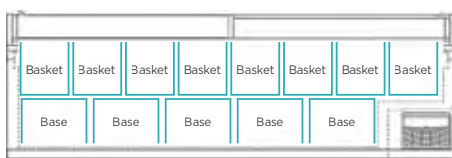

IRENE ECO 250

SPECIAL ORDER



Irene ECO 2505mm Island Freezer

Part No. 3735317 Capacity 1155/815L Weight 202kg

	External (mm)	Internal (mm)
Width	2505	2371
Depth	862	702
Height	852	753

- Curved double-glazed lid offers exceptional product visibility for children and adults alike
- Roll-bond condenser simplifies cleaning, reduces heat emission and saves space
- Temperature range: -25°C to -18°C

Island Freezers

Specification Reference Guide

Model	SPECIAL ORDER	SPECIAL ORDER
	IRENE ECO 185 ISLE END CABINET	IRENE ECO 250
Part Number	3735319	3735317
Ext. Width (mm)*	1856	2505
Ext. Depth (mm)*	862	862
Ext. Height (mm)*	852	852
Capacity	805 / 525L	1155 / 815L
Temp. Range	-25 to -18°C	-25 to -18°C
Max. Ambient Temp.	25°C	25°C
Rated Power	450W	520W
Current	3.5A	3.5A
Gross Weight	161kg	202kg
Refrigerant	R290	R290
Plugs Supplied	2	2
Power Supply	10A	10A
Features		
Total Display Area	1.3 m ²	1.7 m ²
Main Light	Fluorescent	Fluorescent
Number of Lids	2	2
Lid Type	Slide	Slide
Lid Shape	Curved	Curved
Glazed Safety Glass	✓	✓
Digital Temp. Controller	✓	✓
Feet	✓	✓
No. of Baskets Incl.	6	8
No. of Bases Incl.	3	5
Defrosting System	Semi-Automatic	Semi-Automatic
Roll-Bond Condensor	✓	✓
Colour	White	White
Warranty		
Parts (Years)	1	1
Labour (Years)	1	1

Bromic does not warrant that Island Freezer units will work in areas where the Maximum Ambient Temperature & Relative Humidity are higher than 25°C / Max. humidity 60%. Warranty will be voided if unit is used outside these requirements. Units are required to be working in Airconditioned environments only.

*Dimensions exclude handle protrusions. Ventilation strips are recommended when positioning multiple units. We recommend you contact Bromic when considering multiple unit configurations to achieve optimum efficiency in positioning and configuration.

Toughened glass canopy offers greater visibility while maintaining hygiene

Modular profile allows for single row of 5L tubs or double rows of 2.5L tubs (excluding GD0007S)

High-impact LED lighting for perfect product presentation

Electronic controller maintains correct temperature

Automatic defrost with hot gas evaporation eliminates downtime (excluding GD0007S)



Castors make movement & placement easy

Additional internal storage for seamless tub interchange during service

Maintenance free, spiral type condenser for convenience (excluding GD0007S)



Bromic's Gelato Display range offers premium standalone storage and display solutions that are perfect for preserving frozen treats at their ideal serving and storage temperatures.

57. Chest Freezer Display

Bromic's Chest Freezer Gelato Display offers an entry-level unit with the versatility to operate as a chest freezer when not tempting customers with frozen treats.

Featuring a sliding glass lid, curved canopy and distinctive styling, this unit excels in attention-grabbing, front-of-house display.



57. Delight Gelato Display

Bromic's Delight Gelato Displays have been developed in conjunction with internationally-acclaimed manufacturer IARP to offer the ultimate standalone gelato display and storage solution.

With the ability to deep freeze gelato in storage before bringing them up to serving temperature on display, the Delight range can be relied upon to perfectly preserve a range of frozen treats while presenting them proudly.



58. Specification Reference Guide

Gelato Displays

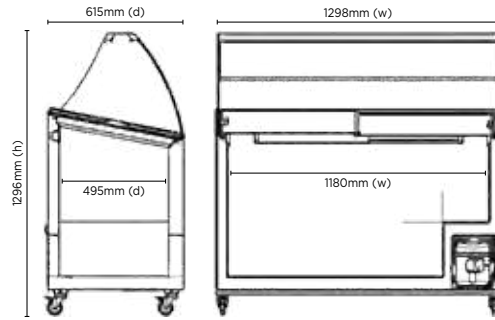

GDO007S



Chest Freezer Gelato Display

Part No.	Capacity	Weight
3735262	352L	81kg
External (mm)		Internal (mm)
Width	1298	1180
Depth	615	495
Height	1296	708

- Tilted display with curved canopy offers great visibility while maintaining hygiene
- Sliding lid minimises energy consumption and keeps contents cool on display
- Included internal frame to accommodate baskets
- Temperature range: -22°C to -12°C
- Includes 7 plastic 5L tubs

Tub Support Framework

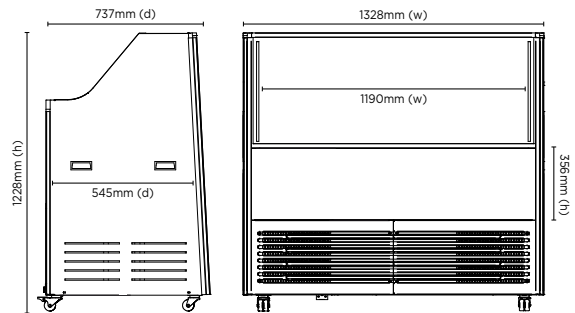
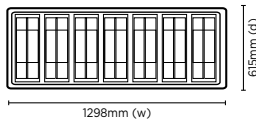

DELIGHT7



Delight Gelato Display - 7 Tub¹

Part No.	Capacity	Weight
3736227	130L+93L	134kg
External (mm)		Internal (mm)
Width	1328	1190
Depth	737	545
Height	1229	356

- Lower front glass with LED lighting for better ice-cream visibility
- Heated front display glass to prevent condensation
- Modular profiles allow for single row of 5L tubs or double rows of 2.5L tubs - please note tubs are not included
- Spiral type, maintenance free condenser
- Temperature range: -15°C to -18°C

¹5L gelato tubs not supplied

Tub Support Framework

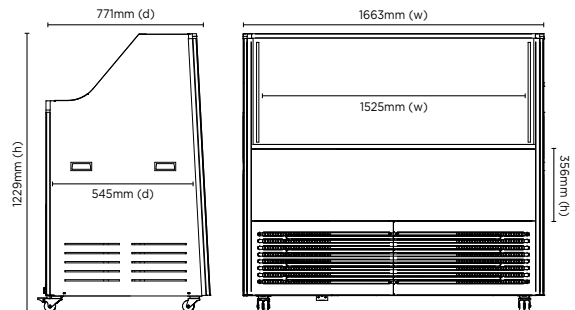
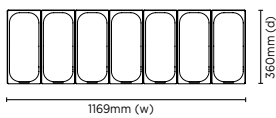

DELIGHT13



Delight Gelato Display - 13 Tub¹

Part No.	Capacity	Weight
3736228	195L+148L	184kg
External (mm)		Internal (mm)
Width	1663	1525
Depth	771	545
Height	1229	356

- Lower front glass with LED lighting for better ice-cream visibility
- Heated front display glass to prevent condensation
- Modular profiles allow for single row of 5L tubs or double rows of 2.5L tubs - please note tubs are not included
- Spiral type, maintenance free condenser
- Temperature range: -15°C to -18°C

¹5L gelato tubs not supplied

Tub Support Framework

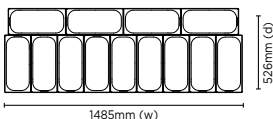

Gelato Displays

Specification Reference Guide

Model	GD0007S	DELIGHT7	DELIGHT13
Part Number	3735262	3736227	3736228
Ext. Width (mm)*	1298	1328	1663
Ext. Depth (mm)*	615	737	771
Ext. Height (mm)*	1296	1229	1229
Capacity	352L	130L + (93L storage)	195L + (148L storage)
Temp. Range	-22 to -12°C	-15°C to -18°C	-15°C to -18°C
Max. Ambient Temp.	35°C	35°C	35°C
Rated Power	300W	N/A	N/A
Current	2.3A	3.6A	3.6A
Gross Weight	81kg	134kg	184kg
Refrigerant	R404a	R290	R290
Plug Supplied	1	1	1
Power Supply	10A	10A	10A
Features			
Main Light	Fluorescent	LED	LED
Number of Lids	2	1	1
Lid Type	Sliding	Plexy	Plexy
Safety Glass Lid	✓	✓	✓
Canopy	✓	✓	✓
Door Lock	✓		
No. of Baskets Incl.	3 (wire frame support tubs)		
No. of Tubs	7 Included (Plastic Tubs)	7 (Tubs not supplied)	13 (Tubs not supplied)
Automatic Defrosting System		✓	✓
No. of Tubs in Storage	7	12	14
Castors	✓	✓	✓
Colour	White	White with Blue Trim	White with Blue Trim
Warranty			
Parts (Years)	1	1	1
Labour (Years)	1	1	1

*Dimensions exclude handle protrusions

Built-in product stops facilitate angled product display

Retractable night blind reduces off-peak energy consumption

Illuminated lightbox increases brand presence

Transparent side glass extends product visibility

Adjustable shelving for flexibility in display configuration

High-impact, full-height LED lighting for perfect product presentation

Invisible air curtain maintains temperature and enables open access to products

Plastic bumpers provide protection from accidental damage

Plug-in design offers flexible unit placement and simplifies installation

Corrosion-resistant construction ensures longevity

Allows display of delicate produce

Castors for easy placement & movement



Bromic's Open Display range offers powerful performance in a plug-in package, creating attractive open displays with exceptionally accurate temperature control.

61. Vision ECO Displays

Bromic's Vision ECO Open Displays have been developed in partnership with internationally-acclaimed manufacturer IARP to offer plug-in solutions that simplify the installation of self-service refrigerated retail aisles.

Accurate temperature controls allow this unit to display delicate produce despite its open front while plug-in operation eliminates the need for prior planning approval and an expensive installation.



62. Specification Reference Guide

PROFESSIONAL RANGE

OPEN DISPLAYS

Open Displays

PROFESSIONAL RANGE

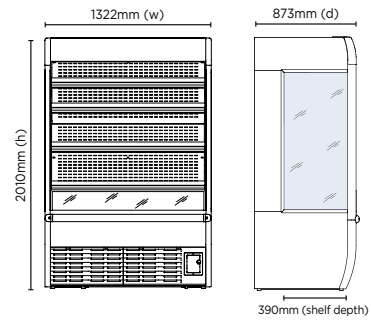

VISION1200



Vision ECO 1330L LED Open Display

Part No.	Capacity	Weight
3335274	1330L	266kg

External (mm)	
Width	1322
Depth	873
Height	2010

- Invisible air curtain maintains temperature
- Adjustable tilt shelves with built-in product stops for easy display set-up
- Included night blind reduces energy consumption during off-peak periods
- Temperature range: 0 to +10°C

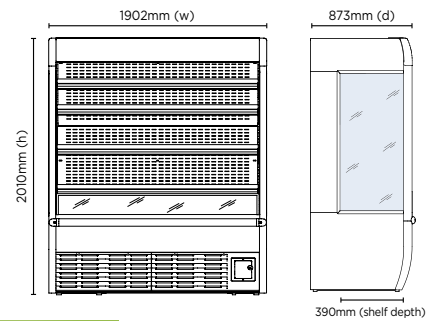

VISION1800



Vision ECO 1913L LED Open Display

Part No.	Capacity	Weight
3335276	1913L	310kg

External (mm)	
Width	1902
Depth	873
Height	2010

- Invisible air curtain maintains temperature
- Adjustable tilt shelves with built-in product stops for easy display set-up
- Included night blind reduces energy consumption during off-peak periods
- Temperature range: 0 to +10°C

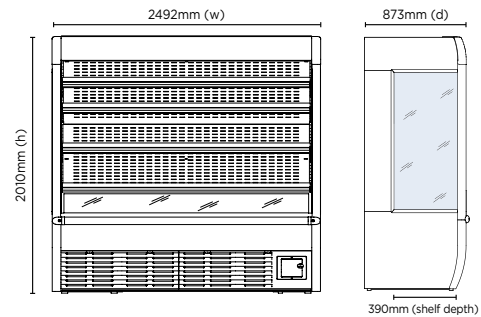

VISION2400



Vision ECO 2555L LED Open Display

Part No.	Capacity	Weight
3335277	2555L	443kg

External (mm)	
Width	2492
Depth	873
Height	2010

- Invisible air curtain maintains temperature
- Adjustable tilt shelves with built-in product stops for easy display set-up
- Included night blind reduces energy consumption during off-peak periods
- Temperature range: 0 to +10°C

Open Displays

Specification Reference Guide

Model	VISION1200	VISION1800	VISION2400
Part Number	3335274	3335276	3335277
Ext. Width (mm)	1322	1902	2492
Ext. Depth (mm)	873	873	873
Ext. Height (mm)	2010	2010	2010
Capacity	1330L	1913L	2555L
Temp. Range	0 to +10°C	0 to +10°C	0 to +10°C
Max. Ambient Temp.	25°C	25°C	25°C
Rated Power	2300W	2650W	3500W
Current	9.6A	13.6A	16.5A
Gross Weight	266kg	310kg	443kg
Refrigerant	R507A	R507A	R507A
Plugs Supplied	1	1	1
Power Supply	10A	15A	20A
Features			
Display Light Box	✓	✓	✓
Main Light	LED	LED	LED
Air Curtain	✓	✓	✓
Analogue Temp. Controller	✓	✓	✓
Feet/Castors	✓	✓	✓
No. of Shelves Incl. Base	5	5	5
Shelf Stops Incl.	✓	✓	✓
Night Blind	✓	✓	✓
Colour	White	White	White
Warranty			
Parts (Years)	1	1	1
Labour (Years)	1	1	1



Bromic's Pizza Prep Fridges help improve kitchen efficiency, providing a practical food preparation space with quick access to your fresh ingredients. Ideal for Sandwich, Juice or Pizza Prep, these counters are Australian Food Safety compliant with dual-airflow channels.

65. Pizza Prep Fridges

The Pizza Prep Fridges are Australian Food Safety compliant with dual airflow channels to ensure consistent and even temperature in food pans.

Featuring a 480mm removable cutting board and enclosed well under pans to stop food from spilling into cabinets.



66. Specification Reference Guide

PROFESSIONAL RANGE

PIZZA PREP FRIDGES

Pizza Prep Fridges

PROFESSIONAL RANGE

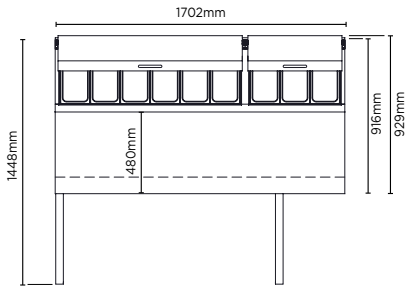
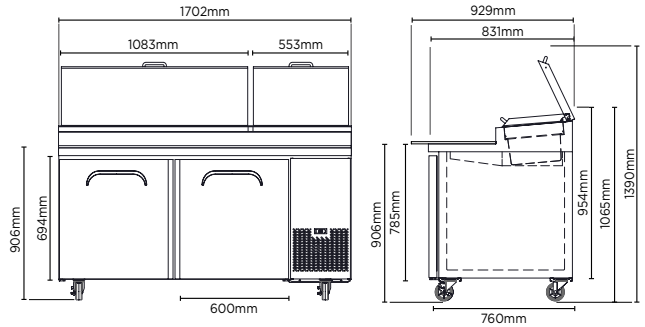

PP1700



Two Door Pizza Prep Fridge (9 Pans)

Part No. 3735801 **Capacity** 572L **Weight** 165kg

	Ext (mm)	Int (mm)
Width	1702	1260
Depth	929	670
Height	1065	590

- Hinged removable insulated lids with option to lock in open position
- Australian Food Safety compliant with dual airflow channels to ensure consistent and even temperature in food pans
- Chilled, fan assisted, blown air over & under food pan & wells
- 9 x removable 1/3" pans & rails
- Temperature range: 0°C to 5°C

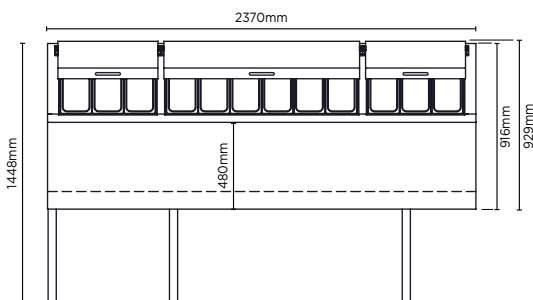
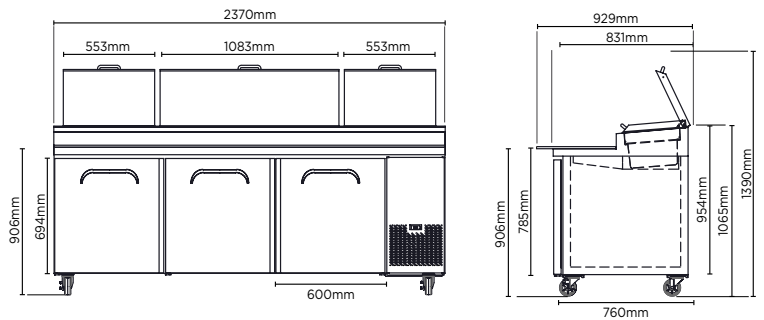

PP2370



Three Door Pizza Prep Fridge (12 Pans)

Part No. 3735802 **Capacity** 873L **Weight** 207kg

	Ext (mm)	Int (mm)
Width	2370	1930
Depth	929	670
Height	1065	590

- Hinged removable insulated lids with option to lock in open position
- Australian Food Safety compliant with dual airflow channels to ensure consistent and even temperature in food pans
- Chilled, fan assisted, blown air over & under food pan & wells
- 12 x removable 1/3" pans & rails
- Temperature range: 0°C to 5°C

Pizza Prep Fridges

Specification Reference Guide

Model	PP1700	PP2370
Part Number	3735801	3735802
Ext. Width (mm)*	1702	2370
Ext. Depth (mm)*	929	929
Ext. Height (mm)*	1065	1065
Capacity	572L	873L
Temp. Range	0°C to +5°C	0°C to +5°C
Max. Ambient Temp.	43°C	43°C
Refrigerant	R134a	R404a
Gross Weight	165kg	207kg
Current	3.4A	4.0A
Plug Supplied	1	1
Power Supply	10A	10A
Features		
Number of Pans	9	12
Tub Dimensions	(GN 1/3") W176mm x D324mm	(GN 1/3") W176mm x D324mm
Removable Cutting Board	✓	✓
Number of Doors	2	3
Door Type	Solid (Flat)	Solid (Flat)
Self-Closing Doors	✓	✓
Digital Temp. Controller	✓	✓
Lockable Castors	✓	✓
Number of Adjustable Shelves	4	6
Shelf Dimensions	W600mm x D643mm	2x W605mm x D643mm ; 4x W660mm x D643mm
Air Circulation	Forced Air	Forced Air
Colour	Stainless Steel	Stainless Steel
Warranty		
Parts (Years)	2	2
Labour (Years)	2	2

*Dimensions exclude any protrusions

Shelves adjustable to three angles

Corrosion-resistant construction ensures longevity

3-shelves + base maximises product display area

Sliding rear door minimises temperature loss

Toughened safety glass creates a durable display & service surface

High-impact LED lighting on each shelf maximises product visibility & captures attention (cold & ambient)

Removable shelf inserts for easy cleaning



Adjustable shelving for flexibility in display configuration

Soft-cool refrigeration maximises freshness

Stainless steel body for improved quality & durability

Castors make movement, placement & cleaning easy

Invisible heat elements & an internal air curtain eliminates condensation

Bromic’s Food Display range offers stylish, purpose built solutions for showcasing your fresh products. Choose from our Hot, Cold and Ambient units, with matching profiles providing a visual consistency for customers whilst beautifully displaying goods.

69. Cold Food Displays

Bromic’s Cold Food Displays offer a stylish, purpose-built display solution for refrigerated delicacies such as cheese, cakes, and confectionary.

With heated glass on the front, top and sides to prevent condensation, it ensures visual clarity of your products on display. Three fully adjustable shelves and high impact LED internal lighting provide display flexibility and help maximise product visibility. Featuring an oversized evaporator coil and low-velocity fans for gentle circulation of high-humidity air, these units maintain moisture at low temperatures to ensure that products on display taste as good as they look.



71. Hot Food Displays

Bromic’s Hot Food Displays offer a flexible and functional solution to display your hot delicacies. These units were designed specifically to provide perfect temperature control and when required, increased humidity to preserve food quality at its highest for prolonged periods of time. In addition, they feature three fully adjustable shelves, removable glass for easy cleaning, sliding self-closing rear door, and high-impact LED internal lighting for perfect product presentation.



73. Ambient Food Displays

Bromic’s Ambient Food Displays offer a perfect solution for displaying your baked goods such as pastries, cookies, cakes at ambient temperature.

With a beautiful stainless-steel finish, these purpose-built food displays offer a modern, sophisticated look that would compliment any hospitality environment. In addition, they feature three fully adjustable shelves with easily removable shelf inserts for cleaning, sliding self-closing rear door for easy access, and high-impact LED internal lighting for the immaculate presentation of your goods.



74. Specification Reference Guide

Cold Food Displays

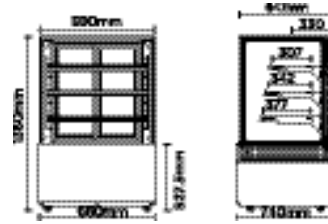

FD4T0660C



Cold Food Display 660mm

Part No. 3736313-NR Capacity 300L Weight 160kg

	External (mm)	Internal (mm)
Width	660	590
Depth	740	647
Height	1360	828

- Heated front, top & side glass provides uninterrupted views
- Magnetic condensor guard and cover for easy maintenance
- Three tiers of adjustable/removable shelving + base for flexibility in display
- Heated hinged rear door for convenience
- Temperature range: +2 to +6°C

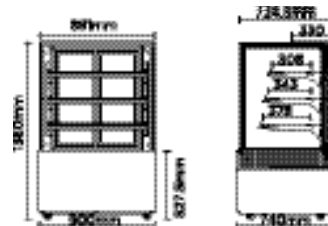

FD4T0900C



Cold Food Display 900mm

Part No. 3736308 Capacity 417L Weight 230kg

	External (mm)	Internal (mm)
Width	900	874
Depth	740	647
Height	1360	828

- Heated front, top & side glass provides uninterrupted views
- Magnetic condensor guard and cover for easy maintenance
- Three tiers of adjustable/removable shelving + base for flexibility in display
- Rear sliding door minimises temperature loss
- Temperature range: +2 to +6°C

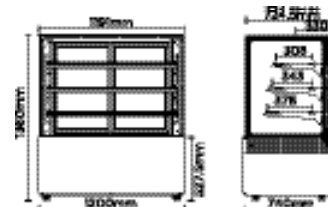

FD4T1200C



Cold Food Display 1200mm

Part No. 3736309 Capacity 542L Weight 282kg

	External (mm)	Internal (mm)
Width	1200	1174
Depth	740	647
Height	1360	828

- Heated front, top & side glass provides uninterrupted views
- Magnetic condensor guard and cover for easy maintenance
- Three tiers of adjustable/removable shelving + base for flexibility in display
- Rear sliding door minimises temperature loss
- Temperature range: +2 to +6°C

Cold Food Displays

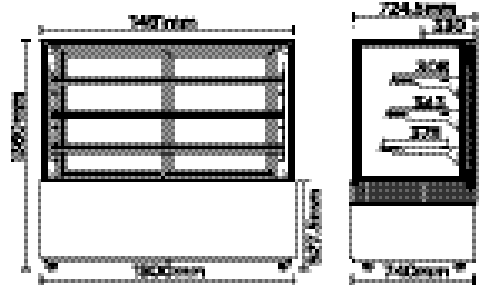

FD4T1500C



Cold Food Display 1500mm

Part No.	Capacity	Weight
3736310	686L	319kg

	External (mm)	Internal (mm)
Width	1500	1474
Depth	740	647
Height	1360	828

- Heated front, top & side glass provides uninterrupted views
- Magnetic condensor guard and cover for easy maintenance
- Three tiers of adjustable/removable shelving + base for flexibility in display
- Rear sliding door minimises temperature loss
- Temperature range: +2 to +6°C

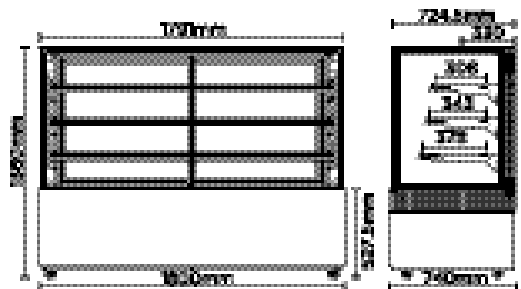

FD4T1800C



Cold Food Display 1800mm

Part No.	Capacity	Weight
3736311	830L	344kg

	External (mm)	Internal (mm)
Width	1800	1774
Depth	740	647
Height	1360	828

- Heated front, top & side glass provides uninterrupted views
- Magnetic condensor guard and cover for easy maintenance
- Three tiers of adjustable/removable shelving + base for flexibility in display
- Rear sliding door minimises temperature loss
- Temperature range: +2 to +6°C

Hot Food Displays

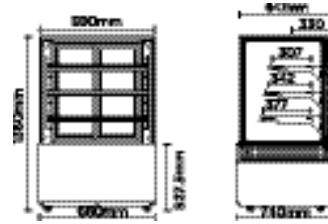

FD4T0660H



Hot Food Display 660mm

Part No. 3736312 **Capacity** 300L **Weight** 140kg

	External (mm)	Internal (mm)
Width	660	590
Depth	740	647
Height	1360	828

- Stainless steel construction resists corrosion and looks fantastic
- Three tiers of adjustable/removable shelving + base for flexibility in display
- Included is a bain-marie for increased humidity
- Hinged rear door for convenience
- Temperature range: +50 to +70°C

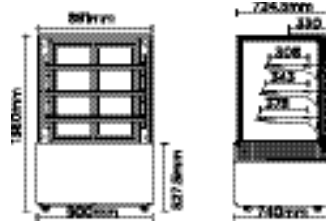

FD4T0900H



Hot Food Display 900mm

Part No. 3736304 **Capacity** 417L **Weight** 186kg

	External (mm)	Internal (mm)
Width	900	874
Depth	740	647
Height	1360	828

- Stainless steel construction resists corrosion and looks fantastic
- Three tiers of adjustable/removable shelving + base for flexibility in display
- Included is a bain-marie for increased humidity
- Temperature range: +50 to +70°C

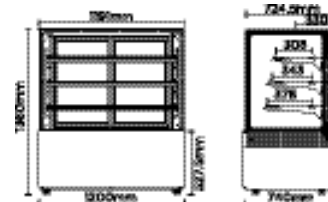

FD4T1200H



Hot Food Display 1200mm

Part No. 3736305 **Capacity** 542L **Weight** 204kg

	External (mm)	Internal (mm)
Width	1200	1174
Depth	740	647
Height	1360	828

- Stainless steel construction resists corrosion and looks fantastic
- Three tiers of adjustable/removable shelving + base for flexibility in display
- Included is a bain-marie for increased humidity
- Temperature range: +50 to +70°C

Hot Food Displays

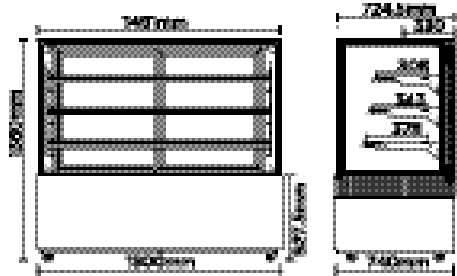

FD4T1500H



Hot Food Display 1500mm

Part No.	Capacity	Weight
3736306	686L	223kg

	External (mm)	Internal (mm)
Width	1500	1474
Depth	740	647
Height	1360	828

- Stainless steel construction resists corrosion and looks fantastic
- Three tiers of adjustable/removable shelving + base for flexibility in display
- Included is a bain-marie for increased humidity
- Temperature range: +50 to +70°C

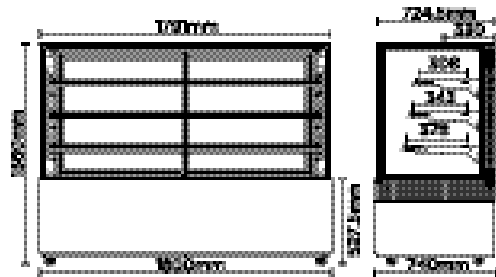

FD4T1800H



Hot Food Display 1800mm

Part No.	Capacity	Weight
3736307	830L	242kg

	External (mm)	Internal (mm)
Width	1800	1774
Depth	740	647
Height	1360	828

- Stainless steel construction resists corrosion and looks fantastic
- Three tiers of adjustable/removable shelving + base for flexibility in display
- Included is a bain-marie for increased humidity
- Temperature range: +50 to +70°C

Ambient Food Displays

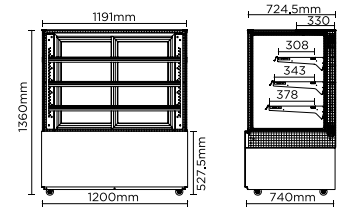
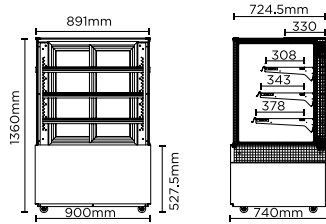

FD4T0900A



Ambient Food Display 900mm

Part No.	Capacity	Weight
3736300	417L	142kg

	External (mm)	Internal (mm)
Width	900	874
Depth	740	647
Height	1360	828

- Stainless steel construction resists corrosion and looks fantastic
- Three tiers of adjustable/removable shelving + base for flexibility in display
- Sliding rear doors allow easy access
- Toughened safety glass creates a durable display & service surface

FD4T1200A



Ambient Food Display 1200mm

Part No.	Capacity	Weight
3736301	542L	174kg

	External (mm)	Internal (mm)
Width	1200	1174
Depth	740	647
Height	1360	828

- Stainless steel construction resists corrosion and looks fantastic
- Three tiers of adjustable/removable shelving + base for flexibility in display
- Sliding rear doors allow easy access
- Toughened safety glass creates a durable display & service surface

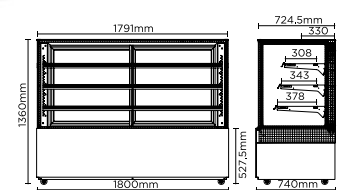
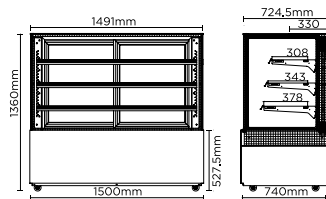

FD4T1500A



Ambient Food Display 1500mm

Part No.	Capacity	Weight
3736302	686L	206kg

	External (mm)	Internal (mm)
Width	1500	1474
Depth	740	647
Height	1360	828

- Stainless steel construction resists corrosion and looks fantastic
- Three tiers of adjustable/removable shelving + base for flexibility in display
- Sliding rear doors allow easy access
- Toughened safety glass creates a durable display & service surface

FD4T1800A



Ambient Food Display 1800mm

Part No.	Capacity	Weight
3736303	830L	238kg

	External (mm)	Internal (mm)
Width	1800	1774
Depth	740	647
Height	1360	828

- Stainless steel construction resists corrosion and looks fantastic
- Three tiers of adjustable/removable shelving + base for flexibility in display
- Sliding rear doors allow easy access
- Toughened safety glass creates a durable display & service surface

Food Displays

Specification Reference Guide

Model	FD4T0660C COLD	FD4T0900C COLD	FD4T1200C COLD	FD4T1500C COLD	FD4T1800C COLD
Part Number	3736313-NR	3736308	3736309	3736310	3736311
Ext. Width (mm)*	660	900	1200	1500	1800
Ext. Depth (mm)*	740	740	740	740	740
Ext. Height (mm)*	1360	1360	1360	1360	1360
Capacity	300L	417L	542L	686L	830L
Temp. Range	+2 to +6°C	+2 to +6°C	+2 to +6°C	+2 to +6°C	+2 to +6°C
Max. Ambient Temp.	32°C	32°C	32°C	32°C	32°C
Rated Power	540W	700W	1000W	1220W	1360W
Gross Weight	160kg	230kg	282kg	319kg	344kg
Refrigerant	R290	R404a	R404a	R404a	R404a
Plug Supplied	1	1	1	1	1
Power Supply	10A	10A	10A	10A	10A
Features					
Main Light	LED	LED	LED	LED	LED
Number of Doors	2	2	2	2	2
Door Type	Slide	Slide	Slide	Slide	Slide
Digital Temp. Controller	✓	✓	✓	✓	✓
Castors	✓	✓	✓	✓	✓
Number of Shelves Incl. Base	4	4	4	4	4
Defrost System	Forced Air	Forced Air	Forced Air	Forced Air	Forced Air
Colour	Stainless Steel	Stainless Steel	Stainless Steel	Stainless Steel	Stainless Steel
Warranty					
Parts (Years)	2	2	2	2	2
Labour (Years)	2	2	2	2	2

*Dimensions exclude any protrusions

Food Displays

Specification Reference Guide

Model	FD4T0660H HOT	FD4T0900H HOT	FD4T1200H HOT	FD4T1500H HOT	FD4T1800H HOT
Part Number	3736312	3736304	3736305	3736306	3736307
Ext. Width (mm)*	660	900	200	1500	1800
Ext. Depth (mm)*	740	740	740	740	740
Ext. Height (mm)*	1360	1360	1360	1360	1360
Capacity	300L	417L	542L	686L	830L
Temp. Range	+50 to +70°C	+50 to +70°C	+50 to +70°C	+50 to +70°C	+50 to +70°C
Max. Ambient Temp.	N/A	N/A	N/A	N/A	N/A
Rated Power	1138W	659W	1000W	1100W	3600W
Gross Weight	140kg	186kg	204kg	223kg	242kg
Refrigerant	N/A	N/A	N/A	N/A	N/A
Plug Supplied	1	1	1	1	1
Power Supply	10A	15A	15A	15A	15A
Features					
Main Light	Fluoro (T5)	Fluoro (T5)	Fluoro (T5)	Fluoro (T5)	Fluoro (T5)
Number of Doors	2	2	2	2	2
Door Type	Slide	Slide	Slide	Slide	Slide
Digital Temp. Controller	✓	✓	✓	✓	✓
Castors	✓	✓	✓	✓	✓
Number of Shelves Incl. Base	4	4	4	4	4
Defrost System	Forced Air	Forced Air	Forced Air	Forced Air	Forced Air
Colour	Stainless Steel	Stainless Steel	Stainless Steel	Stainless Steel	Stainless Steel
Warranty					
Parts (Years)	2	2	2	2	2
Labour (Years)	2	2	2	2	2

Food Displays

Specification Reference Guide

Model	FD4T0900A AMBIENT	FD4T1200A AMBIENT	FD4T1500A AMBIENT	FD4T1800A AMBIENT
Part Number	3736300	3736301	3736302	3736303
Ext. Width (mm)*	900	1200	1500	1800
Ext. Depth (mm)*	740	740	740	740
Ext. Height (mm)*	1360	1360	1360	1360
Capacity	417L	542L	686L	830L
Temp. Range	N/A	N/A	N/A	N/A
Max. Ambient Temp.	N/A	N/A	N/A	N/A
Heating Power	N/A	N/A	N/A	N/A
Gross Weight	142kg	174kg	206kg	238kg
Plug Supplied	1	1	1	1
Power Supply	10A	10A	10A	10A
Features				
Main Light	LED	LED	LED	LED
Number of Doors	2	2	2	2
Door Type	Slide	Slide	Slide	Slide
Digital Temp. Controller	✓	✓	✓	✓
Castors	✓	✓	✓	✓
Number of Shelves Incl. Base	4	4	4	4
Heating System	N/A	N/A	N/A	N/A
Colour	Stainless Steel	Stainless Steel	Stainless Steel	Stainless Steel
Warranty				
Parts (Years)	2	2	2	2
Labour (Years)	2	2	2	2

*Dimensions exclude any protrusions

External stainless steel construction for corrosion resistance and simple cleaning

Retractable door minimises protrusion in tight spaces

Crystal-clear cubes offer sterile cooling in a range of applications



Cooling moves air through vents to reduce horizontal or vertical ventilation clearance

Agion®-treated materials maintain hygiene with antimicrobial technology

Highly-reliable, Italian-made machine

Bromic's Ice Machine range features both self-contained and modular units, operating across a range of production rates and ice styles to provide the perfect solution for any application.

80. Self-Contained Solid Cube Ice

Bromic's Self-Contained Solid Cube Ice Machines provide premium-quality cubes that are perfect for beverage-focused applications. Individually creating large, crystal-clear cubes that maximise liquid displacement while cooling quickly, these self-contained units excel underneath or above counters and are available in a range of sizes.



82. Self-Contained Hollow Ice

Bromic's Self-Contained Hollow Ice Machines present the perfect solution for high-volume venues with diverse ice requirements. Quickly creating lightweight cubes that maximise surface area for rapid cooling, these self-contained units excel underneath or above counters and are available in a range of sizes.



84. Self-Contained Flake Ice

Bromic's Self-Contained Flake Ice Machines continuously produce dry, shapeless ice that is ideal for food display and rapid cooling. These small granules of ice are close to their melting point, making them perfect for delicate produce that could be damaged by more durable forms of ice, such as fresh seafood.



85. Modular Half-Dice Ice

Bromic's Modular Half-Dice Ice Machines are suited to high-volume applications where crystal-clear, general-purpose ice is required in bulk. Rapidly producing slow-melting half-dice ice, these heavy-duty units can comfortably keep up in peak-periods or produce a surplus to be sold on the side.



86. Modular Flake Ice

Bromic's Modular Flake Ice Machines continuously produce dry, shapeless ice on a commercial scale that is ideal for food display and rapid cooling. These small granules of ice are close to their melting point, making them perfect for delicate produce that could be damaged by more durable forms of ice, such as fresh seafood.



87. Stainless Steel Storage Bins

Bromic's Stainless Steel Storage Bins provide a hygienic and sturdy storage solution for modular ice machines.

87. Ice Machine Water Filters

Bromic's Ice Machine Water Filters are an essential part of clear ice production. In addition, ice machine life can be drastically extended by filtering out damaging particulates found in tap water.

88. Daily Ice Production Overview Chart

89. Specification Reference Guide

PROFESSIONAL RANGE

Ice Machines

Types of Ice



Solid Cube Ice

Solid cube ice production creates large cubes individually to simplify service. These premium, crystal-clear cubes are perfect for beverage-focused applications where liquid displacement is important.

Ice Dimensions

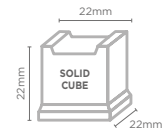

Dice Ice

Dice ice is the most economical style of ice to produce, created in a slab to enable rapid production and easy transport. These hard, pure and slow-melting cubes are perfect for general-purpose use.

Ice Dimensions

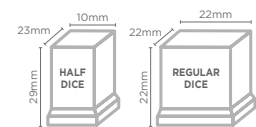

Hollow Ice

Hollow ice is produced individually around refrigerated fingers to maximise surface area and cooling potential. These pure, lightweight cubes are produced rapidly, offer greater surface area for quicker cooling, and are gentler on blender blades.

Ice Dimensions

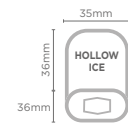

Flake Ice

Flake ice is produced continuously in small, fast-melting granules. This dry, shapeless ice is close to its melting point, allowing it to cool quickly without damaging delicate product or refreezing the melt water.



Bromic Ice Machines are all WaterMark™ approved



Agion® is a silver based antimicrobial compound moulded directly into key ice-machine components. This built-in compound reduces the growth of bacteria, micro-organisms, algae, mould and slime on ice-machines surfaces.

Ice Machines

Self-Contained Solid Cube Ice

PROFESSIONAL RANGE

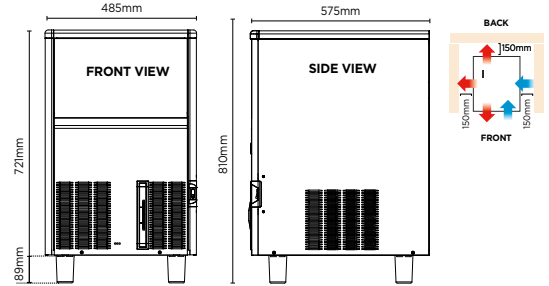

IM0032SSC

3 YEAR*
EXTRA CARE
WARRANTY SERVICE

Self-Contained 31kg Solid Cube Ice Machine

Part No.	Production	Storage	<ul style="list-style-type: none"> Large solid ice cubes that cool quickly and maximise liquid displacement Stainless steel construction resists corrosion Electric PCB controller enables smart yet simple operation Low power and water consumption
3935135	31kg* ²	17kg	
	External (mm)	Footing (mm)	
Width	485		
Depth	575		
Height	721* ³	89	

* 3 years parts only, 1 year labour

*² Production is based on kg/24hr at 10°C air and 10°C water

*³ External height excludes feet

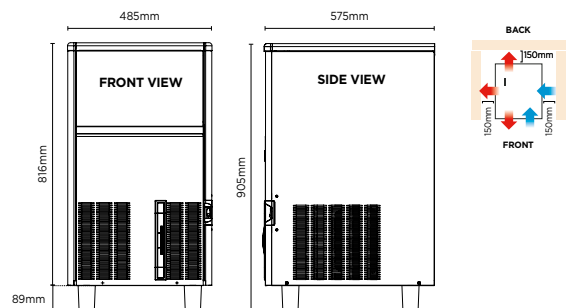

IM0043SSC

3 YEAR*
EXTRA CARE
WARRANTY SERVICE

Self-Contained 37kg Solid Cube Ice Machine

Part No.	Production	Storage	<ul style="list-style-type: none"> Large solid ice cubes that cool quickly and maximise liquid displacement Stainless steel construction resists corrosion Electric PCB controller enables smart yet simple operation Low power and water consumption
3935145	37kg* ²	20kg	
	External (mm)	Footing (mm)	
Width	485		
Depth	575		
Height	816* ³	89	

* 3 years parts only, 1 year labour

*² Production is based on kg/24hr at 10°C air and 10°C water

*³ External height excludes feet



Ice Machines

Self-Contained Solid Cube Ice

PROFESSIONAL RANGE

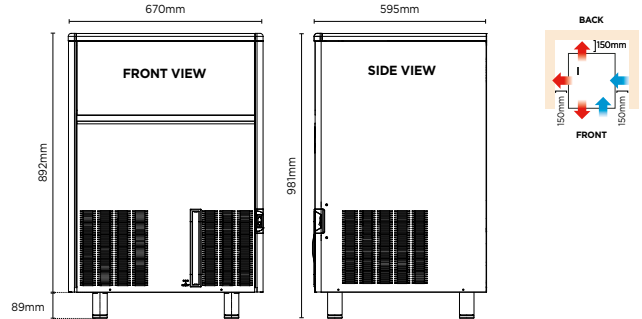

IM0065SSC



Self-Contained 59kg Solid Cube Ice Machine

Part No.	Production	Storage
3935148	59kg* ²	33kg

	External (mm)	Footing (mm)
Width	670	
Depth	595	
Height	892* ³	89

- Large solid ice cubes that cool quickly and maximise liquid displacement
- Stainless steel construction resists corrosion
- Electric PCB controller enables smart yet simple operation
- Low power and water consumption

* 3 years parts only, 1 year labour

*² Production is based on kg/24hr at 10°C air and 10°C water

*³ External height excludes feet

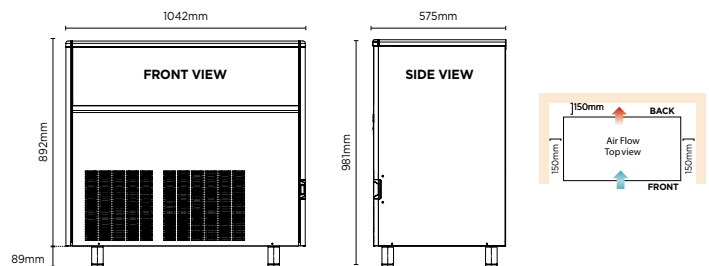

IM0113SSC



Self-Contained 115kg Solid Cube Ice Machine

Part No.	Production	Storage
3935123	115kg* ²	50kg

	External (mm)	Footing (mm)
Width	1042	
Depth	575	
Height	892* ³	89

- Large solid ice cubes that cool quickly and maximise liquid displacement
- Stainless steel construction resists corrosion and looks fantastic
- Electric PCB controller enables smart yet simple operation
- Low power and water consumption

* 3 years parts only, 1 year labour

*² Production is based on kg/24hr at 10°C air and 10°C water

*³ External height excludes feet



Ice Machines

Self-Contained Hollow Ice

PROFESSIONAL RANGE

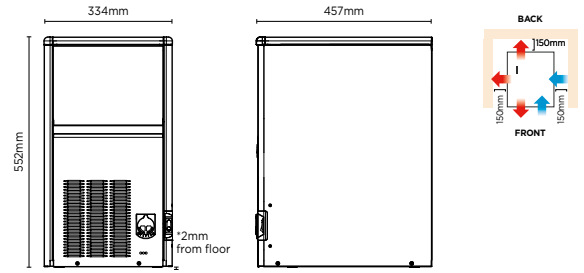

IM0018HSC-HE



Self-Contained 18kg Hollow Ice Machine

Part No.	Production	Storage
3935345	18kg* ²	4kg
	External (mm)	Footing (mm)
Width	334	
Depth	457	
Height	552* ³	2

- Hollow, crystal-clear ice presents the best general-purpose option
- Large surface area cubes result in rapid cooling
- Stainless steel construction resists corrosion
- Low power and water consumption

* 3 years parts only, 1 year labour

² Production is based on kg/24hr at 10°C air and 10°C water

³ External height excludes feet

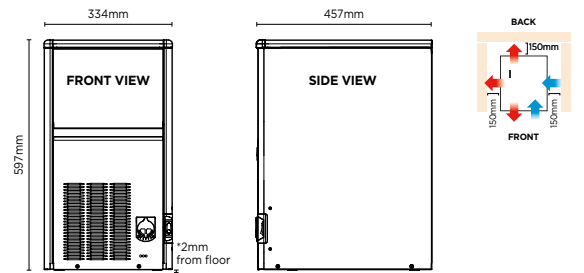

IM0024HSC-HE



Self-Contained 24kg Hollow Ice Machine

Part No.	Production	Storage
3935351	24kg* ²	6kg
	External (mm)	Footing (mm)
Width	334	
Depth	457	
Height	597* ³	2

- Hollow, crystal-clear ice presents the best general-purpose option
- Large surface area cubes result in rapid cooling
- Stainless steel construction resists corrosion
- Low power and water consumption

* 3 years parts only, 1 year labour

² Production is based on kg/24hr at 10°C air and 10°C water

³ External height excludes feet

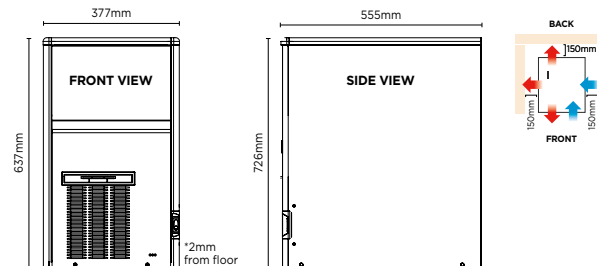

IM0034HSC-HE



Self-Contained 32kg Hollow Ice Machine

Part No.	Production	Storage
3935356	32kg* ²	10kg
	External (mm)	Footing (mm)
Width	377	
Depth	555	
Height	637* ³	2

- Hollow, crystal-clear ice presents the best general-purpose option
- Large surface area cubes result in rapid cooling
- Stainless steel construction resists corrosion
- Low power and water consumption

* 3 years parts only, 1 year labour

² Production is based on kg/24hr at 10°C air and 10°C water

³ External height excludes feet



Ice Machines

Self-Contained Hollow Ice



PROFESSIONAL RANGE

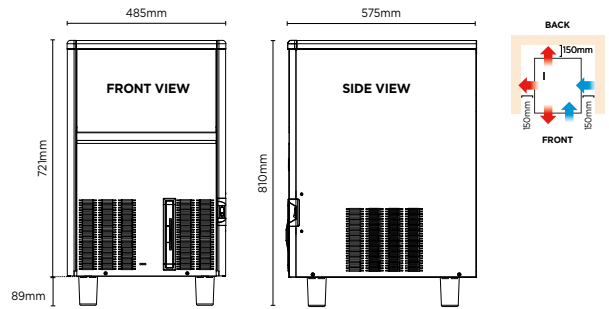

IM0050HSC-HE

Self-Contained 47kg Hollow Ice Machine

Part No.	Production	Storage
3935361	47kg* ²	17kg

	External (mm)	Footing (mm)
Width	485	
Depth	575	
Height	721* ³	89

- Hollow, crystal-clear ice presents the best general-purpose option
- Fast-melting cubes maximise surface area for rapid cooling
- Stainless steel construction resists corrosion
- Low power and water consumption



High Efficiency

* 3 years parts only, 1 year labour
² Production is based on kg/24hr at 10°C air and 10°C water
³ External height excludes feet

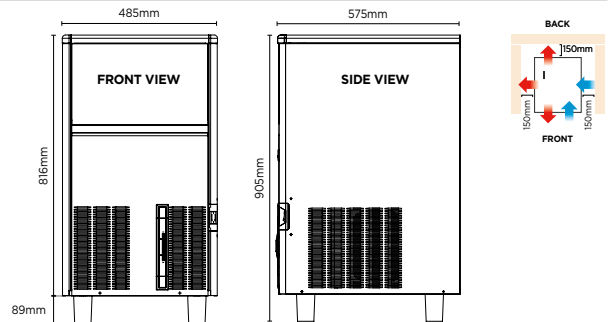

IM0064HSC-HE

Self-Contained 63kg Hollow Ice Machine

Part No.	Production	Storage
3935366	63kg* ²	20kg

	External (mm)	Footing (mm)
Width	485	
Depth	575	
Height	816* ³	89

- Hollow, crystal-clear ice presents the best general-purpose option
- Large surface area cubes result in rapid cooling
- Stainless steel construction resists corrosion
- Low power and water consumption



High Efficiency

* 3 years parts only, 1 year labour
² Production is based on kg/24hr at 10°C air and 10°C water
³ External height excludes feet

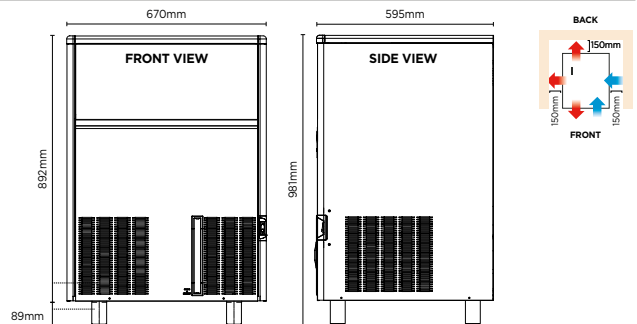

IM0084HSC-HE

Self-Contained 82kg Hollow Ice Machine

Part No.	Production	Storage
3935371	82kg* ²	30kg

	External (mm)	Footing (mm)
Width	670	
Depth	595	
Height	892* ³	89

- Hollow, crystal-clear ice presents the best general-purpose option
- Large surface area cubes result in rapid cooling
- Stainless steel construction resists corrosion
- Low power and water consumption



High Efficiency

* 3 years parts only, 1 year labour
² Production is based on kg/24hr at 10°C air and 10°C water
³ External height excludes feet



Ice Machines

PROFESSIONAL RANGE

Self-Contained Hollow and Flake Ice

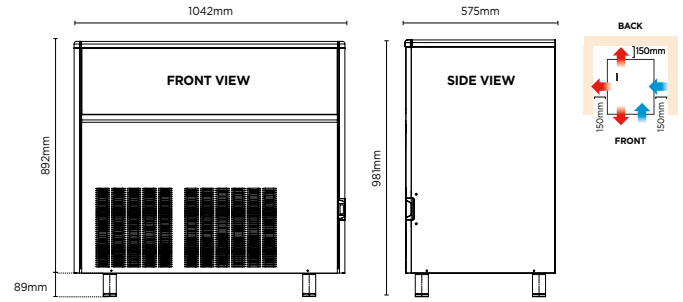

IM0170HSC-HE



Self-Contained 165kg Hollow Ice Machine

Part No.	Production	Storage
3935381	165kg* ²	50kg
	External (mm)	Footing (mm)
	Width 1042	
	Depth 575	
	Height 892* ³	89

- Hollow, crystal-clear ice presents the best general-purpose option
- Stainless steel construction resists corrosion
- Low power and water consumption



* 3 years parts only, 1 year labour
² Production is based on kg/24hr at 10°C air and 10°C water
³ External height excludes feet

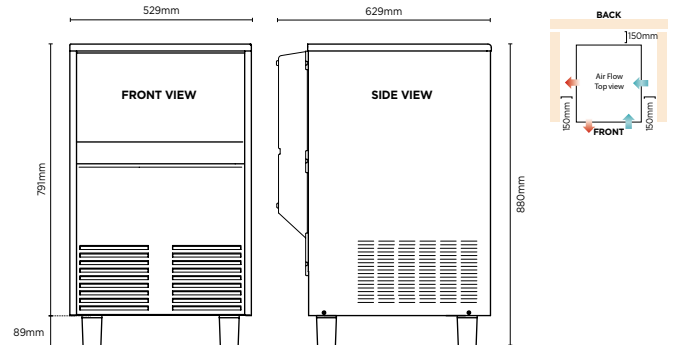

IM0070FSC



Self-Contained 70kg Flake Ice Machine

Part No.	Production	Storage
3935220	70kg* ²	25kg
	External (mm)	Footing (mm)
	Width 529	
	Depth 629	
	Height 791* ³	89

- Shapeless flake ice that cools rapidly without harming delicate produce
- Stainless steel construction resists corrosion
- Electric PCB controller enables smart yet simple operation



* 3 years parts only, 1 year labour
² Production is based on kg/24hr at 10°C air and 10°C water
³ External height excludes feet

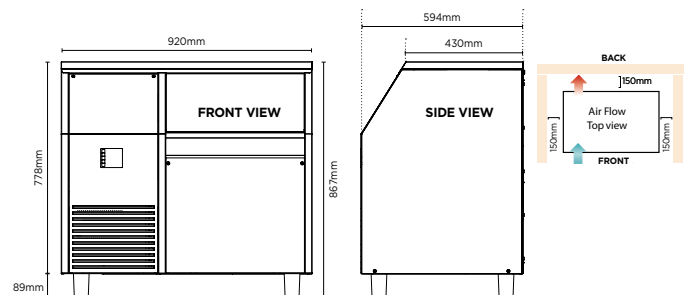

IM0120FSCW



Self-Contained 120kg Flake Ice Machine

Part No.	Capacity	Storage
3935230	120kg* ²	60kg
	External (mm)	Footing (mm)
	Width 920	
	Depth 594	
	Height 778* ³	89

- Shapeless flake ice that cools rapidly without harming delicate produce
- Stainless steel construction resists corrosion
- Electric PCB controller enables smart yet simple operation



* 3 years parts only, 1 year labour
² Production is based on kg/24hr at 10°C air and 10°C water
³ External height excludes feet

Ice Machines

Modular Half-Dice Ice

PROFESSIONAL RANGE

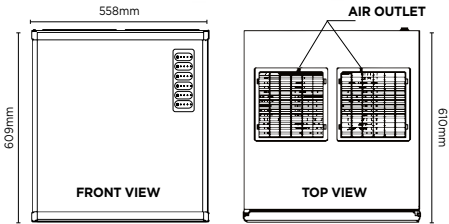

FULL VIEW OF HEAD AND BIN

MODULAR HEAD SHOWN ONLY

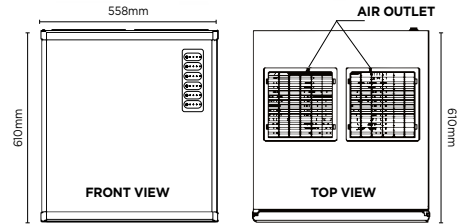

IM0160HDM



Modular 160kg Half-Dice Ice Machine

Part No.	Production	Weight
3935183	160kg* ²	55kg

- Economical half-dice ice suits blending and general-purpose use
- Hard, pure ice that's ready for consumption and cooling alike
- Suitable Storage Bins: SB129, SB178 (CBT30EMCD bin top required), SB243 (CBT30EMCD bin top required)

External (mm)

Width	558
Depth	610
Height	609

* 3 years parts only, 1 year labour

*² Production is based on kg/24hr at 10°C air and 10°C water

IM0250HDM



Modular 250kg Half-Dice Ice Machine

Part No.	Production	Weight
3935185	250kg* ²	65kg

- Economical half-dice ice suits blending and general purpose use
- Hard, pure and crystal-clear ice ready for consumption and cooling alike
- Suitable Storage Bins: SB129, SB178 (CBT30EMCD bin top required), SB243 (CBT30EMCD bin top required)

External (mm)

Width	558
Depth	610
Height	610

* 3 years parts only, 1 year labour

*² Production is based on kg/24hr at 10°C air and 10°C water

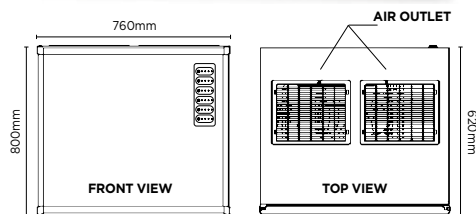
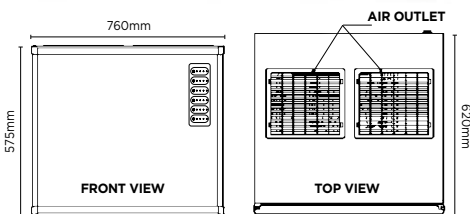

IM0320HDM



Modular 320kg Half-Dice Ice Machine

Part No.	Production	Weight
3935187	320kg* ²	73kg

- Economical half-dice ice suits blending and general purpose use
- Hard, pure ice that's ready for consumption and cooling alike
- Suitable Storage Bins: SB178, SB243 and SB406 (CBT48EAMCD bin top required)

External (mm)

Width	760
Depth	620
Height	575

* 3 years parts only, 1 year labour

*² Production is based on kg/24hr at 10°C air and 10°C water

IM0485HDM



Modular 485kg Half-Dice Ice Machine

Part No.	Production	Weight
3935188	485kg* ²	104kg

- Economical half-dice ice suits blending and general purpose use
- Hard, pure ice that's ready for consumption and cooling alike
- Suitable Storage Bins: SB178, SB243 and SB406 (CTB48FMCD bin top required)

External (mm)

Width	760
Depth	620
Height	800

* 3 years parts only, 1 year labour

*² Production is based on kg/24hr at 10°C air and 10°C water

Ice Machines

Modular Flake Ice

PROFESSIONAL RANGE

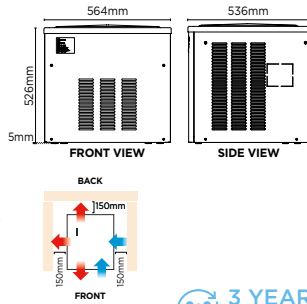

IM0120FM

SPECIAL ORDER

3 YEAR* EXTRA CARE WARRANTY SERVICE

Modular 120kg Flake Ice Machine

Part No. 3935202 **Production** 120kg*² **Weight** 40kg

	External (mm)	Footing (mm)
Width	564	5
Depth	536	
Height	526	

- Shapeless flake ice that cools rapidly without harming delicate produce
- Electric PCB controller enables smart yet simple operation
- Suitable Storage Bins: SB129, SB178 (CBT30EFSD bin top required), SB243 (CBT30EFSD bin top required)

* 3 years parts only, 1 year labour

² Production is based on kg/24hr at 10°C air and 10°C water

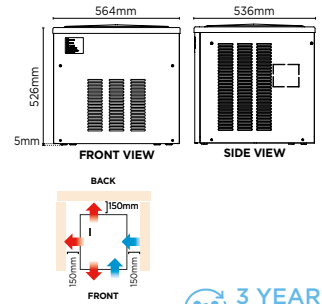

IM0200FM

SPECIAL ORDER

3 YEAR* EXTRA CARE WARRANTY SERVICE

Modular 200kg Flake Ice Machine

Part No. 3935203 **Production** 200kg*² **Weight** 49kg

	External (mm)	Footing (mm)
Width	564	5
Depth	536	
Height	526	

- Shapeless flake ice that cools rapidly without harming delicate produce
- Electric PCB controller enables smart yet simple operation
- Suitable Storage Bins: SB129, SB178 (CBT30EFSD bin top required), SB243 (CBT30EFSD bin top required)

* 3 years parts only, 1 year labour

² Production is based on kg/24hr at 10°C air and 10°C water

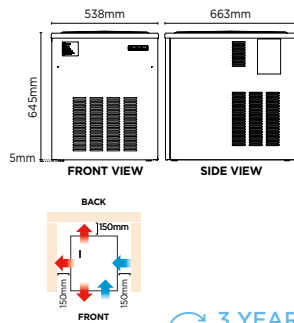

IM0320FM

SPECIAL ORDER

3 YEAR* EXTRA CARE WARRANTY SERVICE

Modular 320kg Flake Ice Machine

Part No. 3935204 **Production** 320kg*² **Weight** 78kg

	External (mm)	Footing (mm)
Width	538	
Depth	663	
Height	645	5

- Shapeless flake ice that cools rapidly without harming delicate produce
- Electric PCB controller enables smart yet simple operation
- Suitable Storage Bins: SB129 (CBT22EFCD bin top required), SB178 (CBT30EFSD bin top required), SB243 (CBT30EFSD bin top required), SB406 (CBT48FMCD bin top required)

* 3 years parts only, 1 year labour

² Production is based on kg/24hr at 10°C air and 10°C water

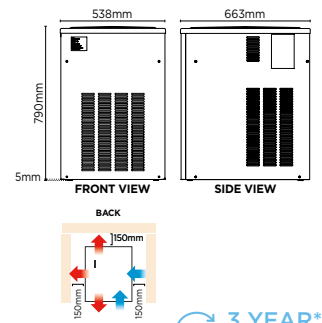

IM0600FM

SPECIAL ORDER

3 YEAR* EXTRA CARE WARRANTY SERVICE

Modular 600kg Flake Ice Machine

Part No. 3935205 **Production** 600kg*² **Weight** 94kg

	External (mm)	Footing (mm)
Width	538	
Depth	663	
Height	790	5

- Shapeless flake ice that cools rapidly without harming delicate produce
- Electric PCB controller enables smart yet simple operation
- Suitable Storage Bins: SB129 (CBT22EFCD bin top required), SB178 (CBT30EFSD bin top required), SB243 (CBT30EFSD bin top required), SB406 (CBT48FMCD bin top required)

* 3 years parts only, 1 year labour

² Production is based on kg/24hr at 10°C air and 10°C water

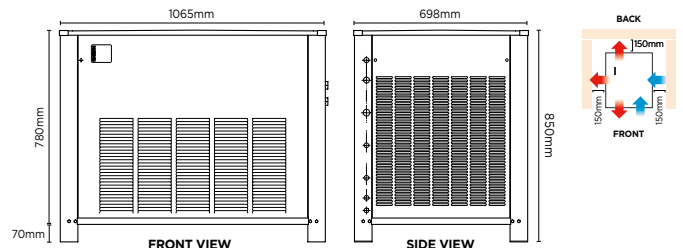

IM1150FM

SPECIAL ORDER

3 YEAR* EXTRA CARE WARRANTY SERVICE

Modular 1150kg Flake Ice Machine

Part No. 3935206 **Production** 1150kg*² **Weight** 179kg

	External (mm)	Footing (mm)
Width	1065	
Depth	698	
Height	780* ³	70

- Shapeless flake ice that cools rapidly without harming delicate produce
- Electric PCB controller enables smart yet simple operation
- Suitable Storage Bin: SB406 (CBT48FMCD bin top required)

* 3 years parts only, 1 year labour

² Production is based on kg/24hr at 10°C air and 10°C water

³ External height excludes feet

Ice Machines

Storage Bins | Water Filters

PROFESSIONAL RANGE

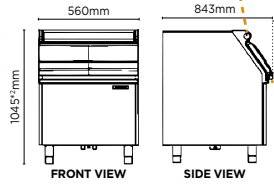

SB129



129kg Storage Bin

Part No.	Capacity	Weight
3935270	129kg	54kg

	External (mm)	Footing (mm)
Width	560	
Depth	843	
Height	1045*2	150

- Insulated with polyurethane to slow melting and maximise ice life
- High-density polyethylene internal liner simplifies cleaning and resists scratching to maintain hygiene
- Durable, corrosion-resistant stainless steel construction provides longevity

* 3 years parts only, 1 year labour
*2 External height includes feet

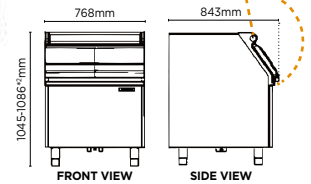

SB178



178kg Storage Bin

Part No.	Capacity	Weight
3935271	178kg	62kg

	External (mm)	Footing (mm)
Width	768	
Depth	843	
Height	1045-1086*2	144-185*3

- Insulated with polyurethane to slow melting and maximise ice life
- High-density polyethylene internal liner simplifies cleaning and resists scratching to maintain hygiene
- Durable, corrosion-resistant stainless steel construction provides longevity

* 3 years parts only, 1 year labour
*2 External height includes adjustable feet.
*3 Adjustable feet.

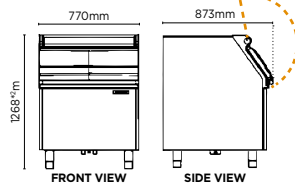

SB243



243kg Storage Bin

Part No.	Capacity	Weight
3935272	243kg	68kg

	External (mm)	Footing (mm)
Width	770	
Depth	873	
Height	1268*2	144

- Insulated with polyurethane to slow melting and maximise ice life
- High-density polyethylene internal liner simplifies cleaning and resists scratching to maintain hygiene
- Durable, corrosion-resistant stainless steel construction provides longevity

* 3 years parts only, 1 year labour
*2 External height includes feet

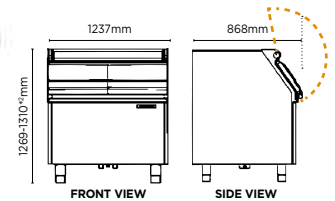

SB406



406kg Storage Bin

Part No.	Capacity	Weight
3935273	406kg	104kg

	External (mm)	Footing (mm)
Width	1237	
Depth	868	
Height	1269-1310*2	144-185*3

- Insulated with polyurethane to slow melting and maximise ice life
- High-density polyethylene internal liner simplifies cleaning and resists scratching to maintain hygiene
- Durable, corrosion-resistant stainless steel construction provides longevity

* 3 years parts only, 1 year labour
*2 External height includes adjustable feet
*3 Adjustable feet



WATER FILTERS







Filter Housing		Cartridge Filter		Filter Kit	
Part No.	Flow Rate	Part No.	Flow Rate	Part No.	Flow Rate
29004	3.8L/pm	45004	3.8L/pm	3935950	3.8L/pm
Micro Rating	Connection	Micro Rating	Connection	Includes:	
n/a	3/4"	5	n/a	- Filter Housing (29004) - Cartridge Filter (45004)	

* Parts only

Refer to bromicrefrigeration.com.au for pre-installation checklist.

Ice Machines

Daily Ice Production Overview Chart

Model	Type	Max Prod. 24 Hour*	Storage Cap.	Dimensions (W x D x H)	Ice Type
IM0032SSC	Self-Contained Solid Cube Ice	31kg	17kg	485 x 575 x 721	Solid Cube Ice 
IM0043SSC	Self-Contained Solid Cube Ice	37kg	20kg	485 x 575 x 816	
IM0065SSC	Self-Contained Solid Cube Ice	59kg	33kg	670 x 595 x 892	
IM0113SSC	Self-Contained Solid Cube Ice	115kg	50kg	1042 x 575 x 892	
IM0018HSC-HE	Self-Contained Hollow Ice	18kg	4kg	334 x 457 x 552	Hollow Ice 
IM0024HSC-HE	Self-Contained Hollow Ice	24kg	6kg	334 x 457 x 597	
IM0034HSC-HE	Self-Contained Hollow Ice	32kg	10kg	377 x 555 x 637	
IM0050HSC-HE	Self-Contained Hollow Ice	47kg	17kg	485 x 575 x 721	
IM0064HSC-HE	Self-Contained Hollow Ice	63kg	20kg	485 x 575 x 816	
IM0084HSC-HE	Self-Contained Hollow Ice	82kg	30kg	670 x 595 x 892	
IM0170HSC-HE	Self-Contained Hollow Ice	165kg	50kg	1042 x 575 x 892	
IM0070FSC	Self-Contained Flake Ice	70kg	25kg	529 x 629 x 791	Flake Ice 
IM0120FSCW	Self-Contained Flake Ice	120kg	60kg	920 x 594 x 778	
IM0160HDM	Modular Half Ice	160kg	N/A	558 x 610 x 609	Half Dice Ice 
IM0250HDM	Modular Half Ice	250kg	N/A	558 x 610 x 610	
IM0320HDM	Modular Half Ice	320kg	N/A	760 x 620 x 575	
IM0485HDM	Modular Half Ice	485kg	N/A	760 x 620 x 800	
IM0120FM	Modular Flake Ice	120kg	N/A	564 x 536 x 526	Flake Ice 
IM0200FM	Modular Flake Ice	200kg	N/A	564 x 536 x 526	
IM0320FM	Modular Flake Ice	320kg	N/A	538 x 663 x 645	
IM0600FM	Modular Flake Ice	600kg	N/A	538 x 663 x 790	
IM1150FM	Modular Flake Ice	1150kg	N/A	1065 x 698 x 780	

*Production is based on kg/24hr at 10°C air and 10°C water

Modular Storage Bin Compatibility Chart

Storage Bin Models		SB129	SB178	SB243	SB406
	Kg/24Hr	129Kg	178Kg	243Kg	406Kg
Modular Half-Dice Ice					
IM0160HDM	160Kg	✓	✓ + CBT30EMCD*	✓ + CBT30EMCD*	
IM0250HDM	250Kg	✓	✓ + CBT30EMCD*	✓ + CBT30EMCD*	
IM0320HDM	320Kg		✓	✓	✓ + CBT48EAMCD*
IM0485HDM	485Kg		✓	✓	✓ + CBT48EAMCD*
Modular Flake Ice					
IM0120FM	120Kg	✓	✓ + CBT30EFSD*	✓ + CBT30EFSD*	
IM0200FM	200Kg	✓	✓ + CBT30EFSD*	✓ + CBT30EFSD*	
IM0320FM	320Kg	✓ + CBT22EFCD*	✓ + CBT30EFSD*	✓ + CBT30EFSD*	✓ + CBT48FMCD*
IM0600FM	600Kg	✓ + CBT22EFCD*	✓ + CBT30EFSD*	✓ + CBT30EFSD*	✓ + CBT48FMCD*
IM1150FM	1150Kg				✓ + CBT48FMCD*

*Additional bin top required with purchase of particular modular bin

Ice Machines

Specification Reference Guide

Model	IM0032SSC	IM0043SSC	IM0065SSC	IM0113SSC
Part Number	3935135	3935145	3935148	3935123
Ext. Width (mm)	485	485	670	1042
Ext. Depth (mm)	575	575	595	575
Ext. Height (mm)*	721	816	892	892
Legs (mm)	89	89	89	89
Maximum Daily Production* ²	31kg	37kg	59kg	115kg
Storage Bin Capacity	17kg	20kg	33kg	50kg
Max. Ambient Temp.* ⁵	40°C	40°C	40°C	40°C
Power Input* ³	380W	530W	650W	1750W
Water Consumption(L/kg)* ⁴	2.9	3.8	2.8	4.4
Net Weight	51kg	52kg	74kg	97kg
Refrigerant	R134a	R134a	R134a	R404a
Plug Supplied	1	1	1	1
Power Supply	10A	10A	10A	10A
Features				
Self-Contained Machine	✓	✓	✓	✓
Modular Machine				
Storage Bin Compatibility	N/A	N/A	N/A	N/A
Type of Ice Produced	Solid	Solid	Solid	Solid
Colour	Stainless Steel	Stainless Steel	Stainless Steel	Stainless Steel
Warranty				
Parts (Years)	3	3	3	3
Labour (Years)	1	1	1	1

* External height excludes feet

*² Production is based on kg/24hr at 10°C air and 10°C water

*³ Power Input calculated at 43°C ambient

*⁴ Water consumption calculated at 32°C air and 21°C water

*⁵ Units operate in ambient conditions between 10°C and 40°C

Ice Machines

Specification Reference Guide

Model	IM0018HSC-HE	IM0024HSC-HE	IM0034HSC-HE	IM0050HSC-HE	IM0064HSC-HE	IM0084HSC-HE
Part Number	3935345	3935351	3935356	3935361	3935366	3935371
Ext. Width (mm)	334	334	377	485	485	670
Ext. Depth (mm)	457	457	555	575	575	595
Ext. Height (mm)*	552	597	637	721	816	892
Legs (mm)	2	2	2	89	89	89
Maximum Daily Production* ²	18kg	24kg	32kg	47kg	63kg	82kg
Storage Bin Capacity	4kg	6kg	10kg	17kg	20kg	30kg
Max. Ambient Temp.* ⁵	40°C	40°C	40°C	40°C	40°C	40°C
Power Input* ³	280W	310W	360W	430W	580W	620W
Water Consumption(L/kg)* ⁴	2.5	2.1	1.9	1.6	2.1	2.0
Net Weight	28kg	28kg	40kg	45kg	48kg	63kg
Refrigerant	R134a	R134a	R134a	R134a	R134a	R134a
Plug Supplied	1	1	1	1	1	
Power Supply	10A	10A	10A	10A	10A	10A
Features						
Self-Contained Machine	✓	✓	✓	✓	✓	✓
Modular Machine						
Storage Bin Compatibility	N/A	N/A	N/A	N/A	N/A	N/A
Type of Ice Produced	Hollow	Hollow	Hollow	Hollow	Hollow	Hollow
Colour	Stainless Steel	Stainless Steel	Stainless Steel	Stainless Steel	Stainless Steel	Stainless Steel
Warranty						
Parts (Years)	3	3	3	3	3	3
Labour (Years)	1	1	1	1	1	1

* External height excludes feet

*² Production is based on kg/24hr at 10°C air and 10°C water

*³ Power Input calculated at 43°C ambient

*⁴ Water consumption calculated at 32°C air and 21°C water

*⁵ Units operate in ambient conditions between 10°C and 40°C

Ice Machines

Specification Reference Guide

Model	SPECIAL ORDER		SPECIAL ORDER		IM0160HDM	IM0250HDM	IM0320HDM
	IM0170HSC-HE	IM0070FSC	IM0120FSCW				
Part Number	3935381	3935220	3935230		3935183	3935185	3935187
Ext. Width (mm)	1042	529	920		558	558	760
Ext. Depth (mm)	575	629	594		610	610	620
Ext. Height (mm)*	892	791	778		609	610	575
Legs (mm)	89	89	89		n/a	n/a	n/a
Maximum 24h Production* ²	165kg	70kg	120kg		160kg	250kg	320kg
Storage Bin Capacity	50kg	25kg	60kg		n/a	n/a	n/a
Max. Ambient Temp.* ⁵	40°C	40°C	40°C		40°C	40°C	40°C
Power Input* ³	1200W	340W	500W		950W	1250W	1600W
Water Consumption(L/kg)* ⁴	2.2	3.2	0.5		1.5	1.4	1.5
Net Weight	94kg	51kg	67kg		55kg	65kg	73kg
Refrigerant	R404A	R134a	R134a		R404a	R404a	R404a
Plug Supplied	1	1	1		1	1	1
Power Supply	10A	10A	10A		10A	16A	16A
Features							
Self-Contained Machine	✓	✓	✓				
Modular Machine					✓	✓	✓
Storage Bin Compatibility (See P.83 for more details)	N/A	N/A	N/A		SB129 SB178 SB243	SB129 SB178 SB243	SB178 SB243 SB406
Type of Ice Produced	Hollow	Flake	Flake		1/2 Dice	1/2 Dice	1/2 Dice
Colour	Stainless Steel	Stainless Steel	Stainless Steel		Stainless Steel	Stainless Steel	Stainless Steel
Warranty							
Parts (Years)	3	3	3		3	3	3
Labour (Years)	1	1	1		1	1	1
Storage Bin							
	SB129		SB178		SB243		SB406
Part Number	3935270		3935271		3935272		3935273
Ext. Width (mm)	560		768		770		1237
Ext. Depth (mm)	843		843		873		868
Ext. Height (mm) Including feet	1045		1045-1086* ⁶		1268		1269-1310* ⁶
Storage Bin Capacity	129kg		178kg		243kg		406kg
Liner Material	Stainless Steel		Stainless Steel		Stainless Steel		Stainless Steel
Gross Weight	54kg		62kg		68kg		104kg
Warranty							
Parts (Years)	3		3		3		3
Labour (Years)	1		1		1		1

Ice Machines

Specification Reference Guide

Model	IM0485HDM	SPECIAL ORDER	SPECIAL ORDER	SPECIAL ORDER	SPECIAL ORDER	SPECIAL ORDER
		IM0120FM	IM0200FM	IM0320FM	IM0600FM	IM1150FM
Part Number	3935188	3935202	3935203	3935204	3935205	3935206
Ext. Width (mm)	760	564	564	538	538	1065
Ext. Depth (mm)	620	536	536	663	663	698
Ext. Height (mm)*	800	526	526	645	790	780
Legs (mm)	n/a	5	5	5	5	70
Maximum 24h Production* ²	485g	120kg	200kg	320kg	600kg	1150kg
Storage Bin Capacity	n/a	n/a	n/a	n/a	n/a	n/a
Max. Ambient Temp.* ⁵	40°C	40°C	40°C	40°C	40°C	40°C
Power Input* ³	2500W	500W	700W	1200W	2000W	3600W
Water Consumption(L/kg)* ⁴	1.4	0.9	0.8	0.8	0.7	0.8
Net Weight	104kg	45kg	49kg	78kg	94kg	179kg
Refrigerant	R404a	R134a	R404a	R404a	R404a	R404a
Plug Supplied	1	1	1	1	1	1
Power Supply	30A	10A	10A	16A	16A	No Plug
Features						
Self-Contained Machine						
Modular Machine	✓	✓	✓	✓	✓	✓
Storage Bin Compatibility	SB178 SB243 SB406	SB129 SB178 SB243	SB129 SB178 SB243	SB129 SB178 SB243 SB406	SB129 SB178 SB243 SB406	SB406
Type of Ice Produced	1/2 Dice	Flake	Flake	Flake	Flake	Flake
Colour	Stainless Steel	Stainless Steel	Stainless Steel	Stainless Steel	Stainless Steel	Stainless Steel
Warranty						
Parts (Years)	3	3	3	3	3	3
Labour (Years)	1	1	1	1	1	1

* External height excludes feet

*² Production is based on kg/24hr at 10°C air and 10°C water

*³ Power Input calculated at 43°C ambient

*⁴ Water consumption calculated at 32°C air and 21°C water (L/100kg)

*⁵ Units operate in ambient conditions between 10°C and 40°C

*⁶ Adjustable feet



Hot gas defrost reduces energy consumption & maintenance (ZN units excluded)

Simple plug-in operation reduces installation cost & time

Low-profile evaporator (drop-in units only) maximises internal cool/freezer room storage space

Reliable L'Unité Hermetique compressor ensures unit longevity

High 45°C tropical ambient temperature rating for reliability in Australian conditions

Three-pin plug with 2m lead for instant power connection

Condensate evaporation system eliminates the need for drainage (drop-in & slide-in units only)*



* Drainage may be required in extreme ambient conditions or when storing high-water-content produce

Bromic Refrigeration are the exclusive Australian distributor of Zanotti's industry-leading cool room refrigeration systems, providing unparalleled functionality and high-performance in Australian conditions.

95. Zanotti Drop-In Refrigeration Systems

Zanotti's Drop-In Refrigeration Systems offer the highest performance and simplest installation within the drop-in category, supplied as a single-phase, plug-in unit with a prewired bulkhead light and a hot gas vaporisation system that eliminates drainage requirements.*



96. Zanotti Slide-In Refrigeration Systems

Zanotti's Slide-In Refrigeration Systems offer the highest performance and simplest installation within the slide-in category, supplied as a single-phase, plug-in unit with a prewired bulkhead light and a hot gas vaporisation system that eliminates drainage requirements.*



98. Zanotti Rotary Refrigeration Systems

Zanotti's Rotary Refrigeration Systems are purpose-designed for the portable preservation of fresh produce, delivering powerful refrigeration from within a package that requires no additional protection to operate externally, whatever the weather.



99. Zanotti Wine Block Refrigeration Systems

Zanotti's Wine Block Refrigeration Systems perfectly maintain temperature and humidity to aid in the delicate development and preservation of a wine's aroma, colour and flavour.



101. Specification Reference Guide

PROFESSIONAL RANGE

Refrigeration Systems

Zanotti Drop-In Refrigeration Systems

PROFESSIONAL RANGE

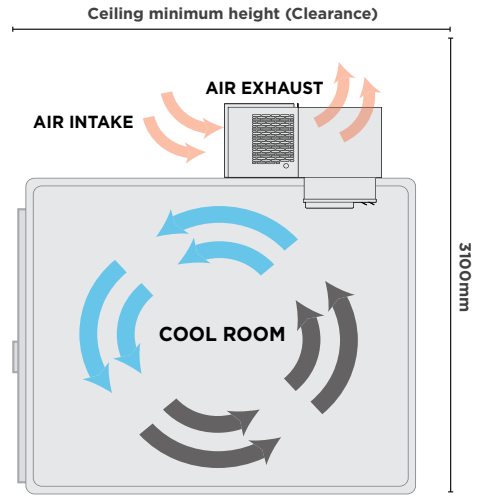

Dropping in from above with minimal protrusion into the room, this system requires vertical clearance for adequate air flow



Digital Controller

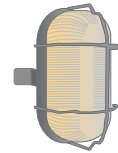

Internal light included



No plumbed drainage required

Chiller Freezer

1 YEAR PARTS ONLY

Zanotti SB Range Drop-In Refrigeration Chiller Systems

- Hot gas defrost reduces energy consumption and maintenance
- Prewired for included bulkhead lighting along with door switches and door heaters
- Touchscreen digital controller enables simple programming and customisation
- Condensate evaporation system eliminates the need for drainage*

MSB125T

Part No. 3835102 Weight 59kg

Run/Full Load Capacity 5.2 / 7.3A 1559W

MSB225N

Part No. 3835103 Weight 74kg

Run/Full Load Capacity 6.3 / 12.0A 2406W

MSB135T

Part No. 3835105 Weight 93kg

Run/Full Load Capacity 12.2 / 21.4A 4722W

*Drainage may be required in extreme ambient conditions or when storing high-water-content

1 YEAR PARTS ONLY

Zanotti SB Range Drop-In Refrigeration Freezer Systems

- Hot gas defrost reduces energy consumption and maintenance
- Prewired for included bulkhead lighting along with door switches and door heaters
- Touchscreen digital controller enables simple programming and customisation
- Condensate evaporation system eliminates the need for drainage*

BSB125T

Part No. 3835150 Weight 68kg

Run/Full Load Capacity 5.5 / 11.3A 1249W

BSB225T

Part No. 3835151 Weight 87kg

Run/Full Load Capacity 7.6 / 17.2A 1782W

BSB135T

Part No. 3835152 Weight 102kg

Run/Full Load Capacity 11.5/25.6A 2611W

*Drainage may be required in extreme ambient conditions or when storing high-water-content

DIMENSIONS:

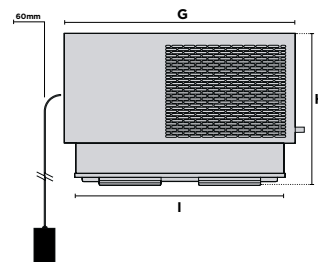
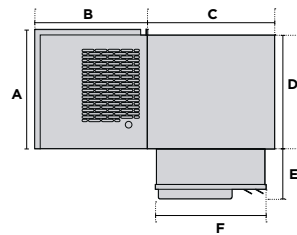

MODEL / MM	MSB125T / BSB125T	MSB225N / BSB225T	MSB135T / BSB135T
A	357	390	427
B	337	427	427
C	382	382	502
D	340	360	410
E	150	150	220
F	332	332	452
G	620	820	820
H	606	540	845
I	545	745	745

Refrigeration Systems

PROFESSIONAL RANGE

Zanotti ZN Range | Slide-In Refrigeration Systems

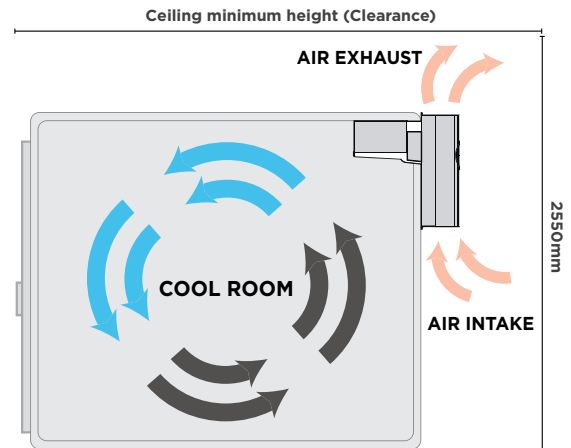

Sliding in from the side, this slim system utilises a vertical air path to minimise clearance requirements

Chiller Freezer

1 YEAR PARTS ONLY

Zanotti ZN Range Slide-In Refrigeration Chiller Systems

- Digital temperature controller simplifies programming and adjustment
- Prewired for included bulkhead lighting along with door switches and door heaters
- Electric defrost to minimise downtime
- Suitable for straddle-wall installation only

MZN106

Part No. 3835210 Weight 41kg

Run/Full Load 4.14 / 5.95A Capacity 1355W

MZN110

Part No. 3835211 Weight 50kg

Run/Full Load 5.19 / 7.32A Capacity 1704W

MZN211

Part No. 3835212 Weight 68kg

Run/Full Load 6.54 / 8.20A Capacity 2299W

MZN213

Part No. 3835213 Weight 66kg

Run/Full Load 8.68 / 11.68A Capacity 3006W

MZN320

Part No. 3835215 Weight 95kg

Run/Full Load 12 / 21.2A Capacity 4463W



No plumbed drainage required*



Internal light included



Digital Controller

DIMENSIONS:

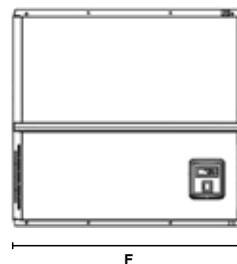
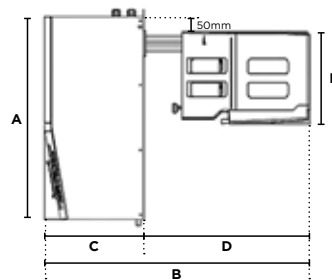

MODEL / MM	MZN106 / MZN110	MZN211 / MZN213 / BZN220	MZN320 / BZN330
A	640	660	660
B	865	865	1055
C	355	325	430
D	510	540	625
E	270	300	375
F	400	760	760

Zanotti ZN Range Slide-In Refrigeration Freezer Systems

- Digital temperature controller simplifies programming and adjustment
- Prewired for included bulkhead lighting along with door switches and door heaters
- Electric defrost to minimise downtime
- Suitable for straddle-wall installation only

BZN218

Part No. 3835220 Weight 64kg

Run/Full Load 6.34 / 9.73A Capacity 1454W

BZN220

Part No. 3835221 Weight 76kg

Run/Full Load 8.6 / 17.65A Capacity 1807W

BZN330

Part No. 3835223 Weight 95kg

Run/Full Load 11.16 / 25.25A Capacity 2605W

1 YEAR PARTS ONLY

Refrigeration Systems

PROFESSIONAL RANGE

Zanotti GM Range | Slide-In Refrigeration Systems

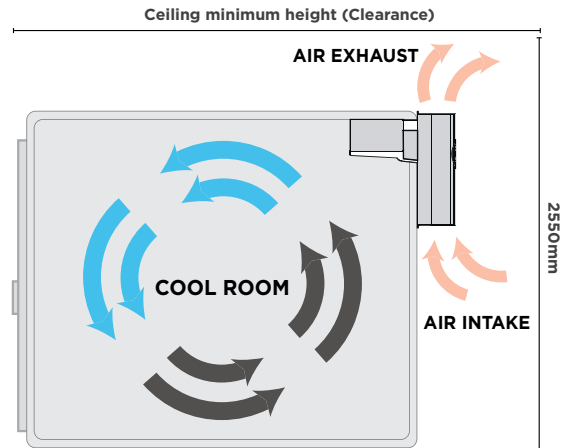

Sliding in from the side, this slim system utilises a vertical air path to minimise clearance requirements

Chiller ■ Freezer ■

SPECIAL ORDER ONLY

1 YEAR PARTS ONLY

Zanotti GM Range Slide-In Refrigeration Chiller Systems

- Touchscreen digital controller enables simple programming and customisation
- Prewired for included bulkhead lighting along with door switches and door heaters
- Hot gas defrost reduces energy consumption and maintenance
- Suitable for straddle-wall installation only

MGM106		MGM110	
Part No.	3835201	Part No.	3835203
Weight	56kg	Weight	64kg
Run/Full Load	4.4 / 6.2A	Run/Full Load	5.6 / 11.3A
Capacity	1299W	Capacity	1697W
MGM211		MGM213	
Part No.	3835204	Part No.	3835205
Weight	80kg	Weight	80kg
Run/Full Load	6.7 / 12.4A	Run/Full Load	8.7 / 11.9A
Capacity	2274W	Capacity	2971W
MGM315		MGM320	
Part No.	3835206	Part No.	3835207
Weight	98kg	Weight	100kg
Run/Full Load	8.2 / 15.8A	Run/Full Load	11.6 / 20.8A
Capacity	3996W	Capacity	4455W



New touchscreen digital controller



Internal light included



No plumbed drainage required*

DIMENSIONS:

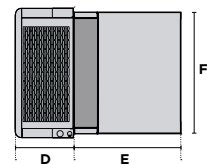
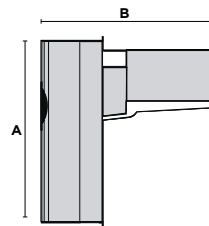

MODEL / MM	MGM106 / MGM110	MGM211 / 213 BGM218 / 220	MGM315 / 320 BGM320 / 330
A	735	830	830
B	790	790	862
C	400	620	620
D	280	280	350
E	510	510	512
F	368	585	585

SPECIAL ORDER ONLY

1 YEAR PARTS ONLY

Zanotti GM Range Slide-In Refrigeration Freezer Systems

- Touchscreen digital controller enables simple programming and customisation
- Prewired for included bulkhead lighting along with door switches and door heaters
- Hot gas defrost reduces energy consumption and maintenance
- Suitable for straddle-wall installation only

BGM218		BGM220	
Part No.	3835254	Part No.	3835251
Weight	80kg	Weight	80kg
Run/Full Load	6.4 / 9.8A	Run/Full Load	8.1 / 17.7A
Capacity	1487W	Capacity	1779W
BGM320		BGM330	
Part No.	3835252	Part No.	3835253
Weight	105kg	Weight	105kg
Run/Full Load	10.6 / 17.8A	Run/Full Load	10.7 / 24.8A
Capacity	2392W	Capacity	2820W

Refrigeration Systems

PROFESSIONAL RANGE

Zanotti Rotary Refrigeration Systems



Supplied with power lead making for fast operation

Suitable for all weather conditions



Lockable temperature display avoids accidental interference

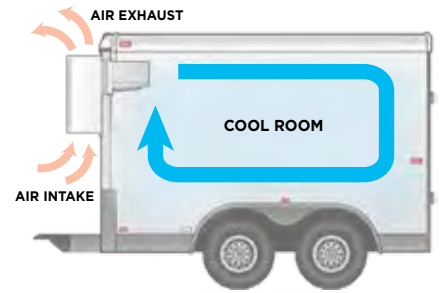

This rugged system has been purpose-designed for mobile cooling, featuring a weatherproof case, shockproof internals and flexible power supply

MAS123T

SPECIAL ORDER ONLY

1 YEAR PARTS ONLY

Zanotti AS Range Rotary Refrigeration Chiller System

Part No. 3835405	Weight 58 Kg	<ul style="list-style-type: none"> • Portable unit with prewired electrical connections for rapid installation • Compressor crankcase heater for reliable operation in cold climates • Rugged ABS-material external casing withstands any weather • Fixed 15A plug allows connection to mains power when stationary
Run/Full Load 4.2 / 8.0A	Capacity 1657W	

DIMENSIONS:

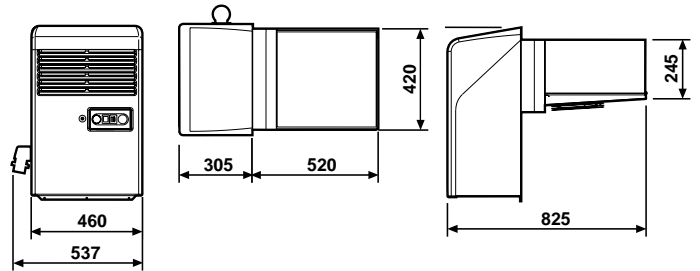

Supplied with power lead making for fast operation

Suitable for all weather conditions



Lockable temperature display avoids accidental interference

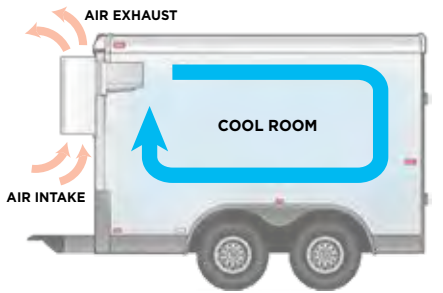

This rugged system has been purpose-designed for mobile cooling, featuring a weatherproof case, shockproof internals and flexible power supply

SPECIAL ORDER ONLY

1 YEAR PARTS ONLY

Zanotti AS Range Rotary Refrigeration Chiller System

- Portable unit with prewired electrical connections for rapid installation
- Compressor crankcase heater for reliable operation in cold climates
- Rugged ABS-material external casing withstands any weather
- Fixed 15A plug allows connection to mains power when stationary

MAS221T

Part No.
3835401

Weight
78kg

MAS221N

Part No.
3835402

Weight
78kg

Run/Full Load
8.06 / 9.26A

Capacity
2550W

Run/Full Load
5.76 / 6.76A

Capacity
2363W

DIMENSIONS:

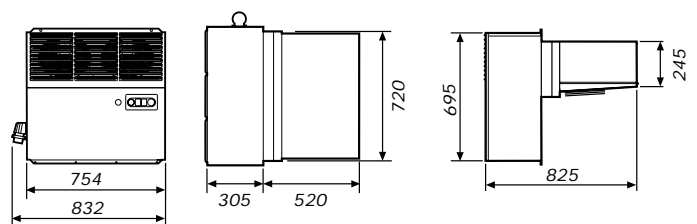

Refrigeration Systems

Zanotti Wine Block Refrigeration Systems

PROFESSIONAL RANGE

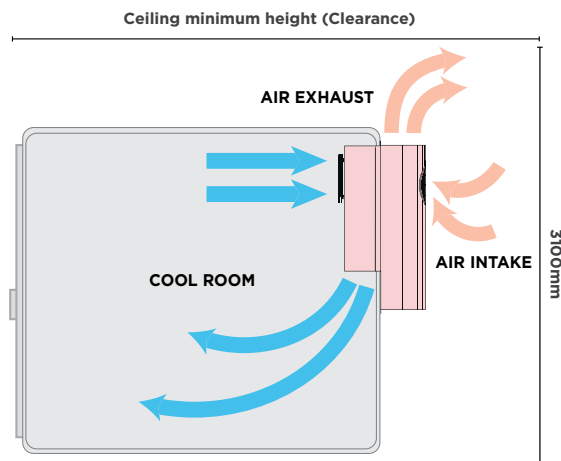

Sliding in from the side, this system's constant circulation maintains the perfect climate for delicate wines



Digital Controller

SPECIAL ORDER ONLY



Zanotti CV Range Wine Block Slide-In Systems

- Wine block systems have adjustable humidity between 60-80%
- Constant circulation and humidity control creates a consistent climate
- Low energy consumption for a highly-efficient permanent storage solution
- Soundproofed condenser cover improves aesthetic appeal while minimising noise
- Water supply required for humidification

RCV101

Part No. 3835040
Weight 49kg

Run/Full Load 5.6 / 6.0A
Capacity 600W

RCV102

Part No. 3835055
Weight 52kg

Run/Full Load 8.2 / 8.9A
Capacity 1000W

RCV201

Part No. 3835060
Weight 77kg

Run/Full Load 11.9 / 13.0A
Capacity 1400W

RCV202

Part No. 3835065
Weight 79kg

Run/Full Load 14.1 / 16.9A
Capacity 2000W

DIMENSIONS:

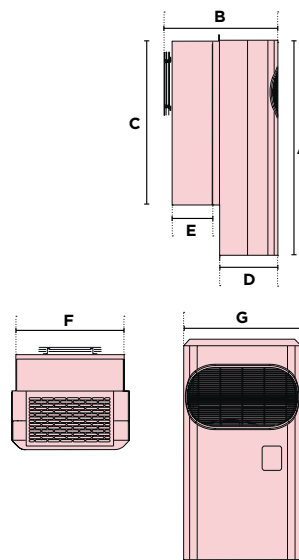

MODEL / MM	RCV101 / RCV102	RCV201	RCV202
A	735	735	735
B	435	435	435
C	570	570	570
D	215	215	215
E	182	182	182
F	375	595	595
G	400	620	620

Refrigeration Systems

PROFESSIONAL RANGE

Zanotti Wine Block Refrigeration Systems



Ceiling Mount Evaporator



Wall Mount Evaporator

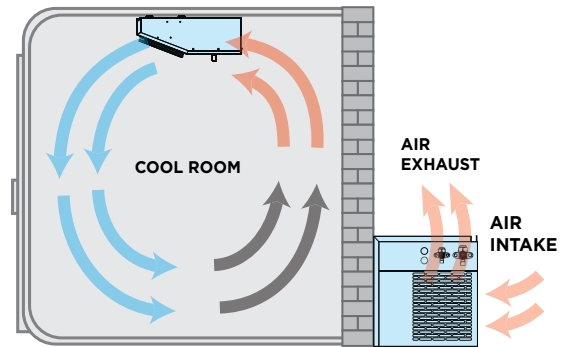

Joined to the in-room evaporator with pre-charged, quick-connect piping, this system's remote condenser can operate up to 10m away in fresh air



Condenser



Digital Controller

SPECIAL ORDER ONLY



Zanotti DV Range Wine Block Split Systems

- Wine block systems have adjustable humidity between 60-80%
- Constant circulation and humidity control creates a consistent climate
- Low energy consumption for a highly-efficient permanent storage solution
- Split system allows remote compressor mounting with quick-connect, pre-charged piping
- Water supply required for humidification

Ceiling Mount Systems

RDV101C

Part No. 3835010 Weight 46kg

Run/Full Load 7.3 / 8.0A Capacity 600W

RDV102C

Part No. 3835023 Weight 49kg

Run/Full Load 8.9 / 9.6A Capacity 1000W

RDV201C

Part No. 3835027 Weight 80kg

Run/Full Load 12.4 / 13.5A Capacity 1400W

RDV202C

Part No. 3835406 Weight 82kg

Run/Full Load 13.8 / 15.3A Capacity 2000W

Wall Mount Systems

RDV101W

Part No. 3835404 Weight 46kg

Run/Full Load 7.3 / 8.0A Capacity 600W

RDV102W

Part No. 3835407 Weight 49kg

Run/Full Load 8.9 / 9.6A Capacity 1000W

RDV201W

Part No. 3835028 Weight 80kg

Run/Full Load 12.4 / 13.5A Capacity 1400W

RDV202W

Part No. 3835403 Weight 82kg

Run/Full Load 13.8 / 15.3A Capacity 2000W

DIMENSIONS:

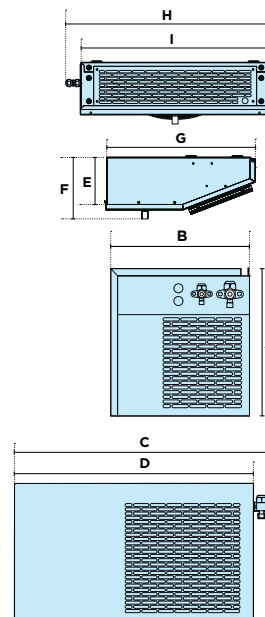

MODEL / MM	RDV101C / RDV101W	RDV102C / RDV102W	RDV201C / RDV201W	RDV202C / RDV202W
A	357	357	390	390
B	337	337	427	427
C	682	682	882	882
D	620	620	820	820
E	215	215	215	215
F	175	175	175	175
G	490	490	490	490
H	669	669	1089	1089
I	614	614	1034	1034

Refrigeration Systems

Chiller

Freezer

Specification Reference Guide

SLIDE-IN MODELS	MZN106	MZN110	MZN211	MZN213	MZN320	BZN218	BZN220	BZN330
Part Number	3835210	3835211	3835212	3835213	3835215	3835220	3835221	3835223
Refrigeration Power	1355W	1704W	2299W	3006W	4463W	1454W	1807W	2605W
Temp. Range (°C)*	-5° to +10°	-5° to +10°	-5° to +10°	-5° to +10°	-5° to +10°	-25° to -5°	-25° to -5°	-25° to -5°
Max Ambient Temp. (°C)	45°C	45°C	45°C	45°C	45°C	45°C	45°C	45°C
Run/Full-Load (Amps)	4.14/5.95A	5.19/7.32A	6.54/8.2A	8.68/11.86A	12/21.2A	6.34/9.73A	8.06/17.65A	11.16/25.25A
Ext. Dimensions	See pg. 96	See pg. 96	See pg. 96	See pg. 96	See pg. 96	See pg. 96	See pg. 96	See pg. 96
Temp. Display	Digital	Digital	Digital	Digital	Digital	Digital	Digital	Digital
Interior Light	Yes	Yes	Yes	Yes	Yes	Yes	Yes	Yes
Gross Weight (kg)	41kg	50kg	68kg	66kg	95kg	67kg	76kg	95kg
Refrigerant	R404a	R404a	R404a	R404a	R404a	R404a	R404a	R404a
Refrigerant weight	0.41kg	0.35kg	0.60kg	0.75kg	0.80kg	0.70kg	0.50kg	0.95kg
Plug Supplied	10A	10A	10A	15A	25A	10A	25A	32A
Features								
Defrost Type	Electronic	Electronic	Electronic	Electronic	Electronic	Electronic	Electronic	Electronic
Type of Control	Digital	Digital	Digital	Digital	Digital	Digital	Digital	Digital
Pre-wired For Internal Light	✓	✓	✓	✓	✓	✓	✓	✓
Pre-wired For Heated Door Trim						✓	✓	✓
No Drainage Required*	✓	✓	✓	✓	✓	✓	✓	✓
Warranty								
Parts (Years)	1	1	1	1	1	1	1	1

* Low temperature rated at -20°C internal temperature, 30°C ambient temperature for freezers. Medium temperature rated at 5°C internal temperature, and 30°C ambient temperature for chillers.

POWER DATA

MZN106										MZN110										MZN211										MZN213										MZN320									
T _a °C	F _h °C	F _l °C	F _h °C	F _l °C	W _h kW	W _l kW	W _h kW	W _l kW	W _h kW	T _a °C	F _h °C	F _l °C	F _h °C	F _l °C	W _h kW	W _l kW	W _h kW	W _l kW	W _h kW	T _a °C	F _h °C	F _l °C	F _h °C	F _l °C	W _h kW	W _l kW	W _h kW	W _l kW	W _h kW	T _a °C	F _h °C	F _l °C	F _h °C	F _l °C	W _h kW	W _l kW	W _h kW	W _l kW	W _h kW										
20	20	10	20	10	1.355	1.000	1.355	1.000	1.355	20	20	10	20	10	1.704	1.250	1.704	1.250	1.704	1.250	20	20	10	20	10	2.299	1.750	2.299	1.750	2.299	20	20	10	20	10	3.006	2.250	3.006	2.250	3.006									

Refrigeration Systems

Specification Reference Guide

Chiller

Freezer

SLIDE-IN MODELS	SPECIAL ORDER	SPECIAL ORDER	SPECIAL ORDER	SPECIAL ORDER	SPECIAL ORDER	SPECIAL ORDER	SPECIAL ORDER	SPECIAL ORDER	SPECIAL ORDER	SPECIAL ORDER
	MGM106	MGM110	MGM211	MGM213	MGM315	MGM320	BGM218	BGM220	BGM320	BGM330
Part Number	3835201	3835203	3835204	3835205	3835206	3835207	3835254	3835251	3835252	3835253
Refrigeration Power	1299W	1697W	2274W	2971W	3996W	4455W	1487W	1779W	2392W	2820W
Temp. Range (°C)*	-5 to +10°	-5 to +10°	-5 to +10°	-5 to +10°	-5 to +10°	-5 to +10°	-25° to -5°	-25° to -5°	-25° to -5°	-25° to -5°
Max Ambient Temp. (°C)	45°C	45°C	45°C	45°C	45°C	45°C	45°C	45°C	45°C	45°C
Run/Full-Load (Amps)	4.4/6.2A	5.6/11.3A	6.7/12.4A	8.7/11.9A	8.2/15.8A	11.6/20.8A	6.4/9.8A	8.1/17.7A	10.6/17.8A	10.7/24.8A
Ext. Dimensions	See pg. 97	See pg. 97	See pg. 97	See pg. 97	See pg. 97	See pg. 97	See pg. 97	See pg. 97	See pg. 97	See pg. 97
Temp. Display	Digital	Digital	Digital	Digital	Digital	Digital	Digital	Digital	Digital	Digital
Interior Light	Yes	Yes	Yes	Yes	Yes	Yes	Yes	Yes	Yes	Yes
Gross Weight (kg)	56kg	64kg	80kg	80kg	98kg	100kg	80kg	80kg	105kg	105kg
Refrigerant	R404a	R404a	R404a	R404a	R404a	R404a	R404a	R404a	R404a	R404a
Plug Supplied	15A	15A	15A	15A	25A	25A	15A	25A	25A	25A
Features										
Defrost Type	Hot Gas	Hot Gas	Hot Gas	Hot Gas	Hot Gas	Hot Gas	Hot Gas	Hot Gas	Hot Gas	Hot Gas
Type of Control	Touch Screen	Touch Screen	Touch Screen	Touch Screen	Touch Screen	Touch Screen	Touch Screen	Touch Screen	Touch Screen	Touch Screen
Pre-wired For Internal Light	✓	✓		✓	✓	✓	✓	✓	✓	✓
Pre-wired For Heated Door Trim							✓	✓	✓	✓
No Drainage Required*	✓	✓		✓	✓	✓	✓	✓	✓	✓
Warranty										
Parts (Years)	1	1	1	1	1	1	1	1	1	1

* Low temperature rated at -20°C internal temperature, 30°C ambient temperature for freezers.
Medium temperature rated at 5°C internal temperature, and 30°C ambient temperature for chillers.

POWER DATA

MGM106							MGM110							MGM211							MGM213							MGM315							MGM320													
Tc °C	Ta °C	P kW	Q kcal/h	Q V220 m³	V100 m³	V50 m³	Tc °C	Ta °C	P kW	Q kcal/h	Q V220 m³	V100 m³	V50 m³	Tc °C	Ta °C	P kW	Q kcal/h	Q V220 m³	V100 m³	V50 m³	Tc °C	Ta °C	P kW	Q kcal/h	Q V220 m³	V100 m³	V50 m³	Tc °C	Ta °C	P kW	Q kcal/h	Q V220 m³	V100 m³	V50 m³	Tc °C	Ta °C	P kW	Q kcal/h	Q V220 m³	V100 m³	V50 m³							
00	2376	2043	26	23	20	20	00	2376	2043	26	23	20	20	00	2376	2043	26	23	20	20	00	2376	2043	26	23	20	20	00	2376	2043	26	23	20	20	00	2376	2043	26	23	20	20							
-15	20798	1804	21	19	16	16	-15	20798	1804	21	19	16	16	-15	20798	1804	21	19	16	16	-15	20798	1804	21	19	16	16	-15	20798	1804	21	19	16	16	-15	20798	1804	21	19	16	16	-15	20798	1804	21	19	16	16
00	1779	1392	16	14	12	12	00	1779	1392	16	14	12	12	00	1779	1392	16	14	12	12	00	1779	1392	16	14	12	12	00	1779	1392	16	14	12	12	00	1779	1392	16	14	12	12	00	1779	1392	16	14	12	12

Refrigeration Systems 103

Refrigeration Systems

Chiller

Freezer

Specification Reference Guide

ROTARY SYSTEM MODELS	SPECIAL ORDER	SPECIAL ORDER	SPECIAL ORDER
	MAS123T	MAS221T	MAS221N
Part Number	3835405	3835401	3835402
Refrigeration Power	1657W	2550W	2363W
Temp. Range (°C)*	-5 to +10°	-5 to +10°	-5 to +10°
Max Ambient Temp (°C)	45°C	45°C	45°C
Run/Full-Load (Amps)	4.2/8.0A	8.06/9.26A	5.76/6.76A
Single Phase Required	Yes	Yes	Yes
Ext. Dimensions	See pg. 98	See pg. 98	See pg. 98
Temp. Display	Digital	Digital	Digital
Gross Weight (kg)	58kg	78kg	78kg
Refrigerant	R407C	R407C	R407C
Recommended Room Capacity	10m ²	19m ²	19m ²
Plug Supplied	15A	15A	15A
Features			
Defrost Type	Hot Gas	Hot Gas	Hot Gas
Type of Control	Electronic	Electronic	Electronic
Warranty			
Parts (Years)	1	1	1

* Medium temperature rated at 5°C internal temperature, and 30°C ambient temperature.

POWER DATA

MAS123T

Tc °C	Ta °C	P watt	P Kcal/h	V100 m ³	V80 m ³	V60 m ³
	20	2035	1750	19	17	16
	25	1936	1665	18	16	15
10	30	1835	1578	17	15	14
	35	1731	1489	16	15	13
	40	1624	1397	15	14	12
	45	1515	1303	13	12	11
	20	1849	1587	17	15	14
	25	1752	1507	16	15	13
5	30	1657	1425	15	14	12
	35	1560	1342	14	13	12
	40	1460	1256	13	12	11
	45	1358	1168	11	10	9.1
	20	1655	1423	15	14	12
	25	1568	1348	14	13	12
0	30	1480	1272	13	12	11
	35	1389	1195	12	11	10
	40	1296	1115	11	10	9.1
	45	1200	1032	9.6	8.7	8
	20	1485	1260	13	12	11
	25	1385	1191	12	11	10
-5	30	1302	1120	11	10	9.1
	35	1218	1047	9.6	8.9	8.1
	40	1132	974	8.8	8	7.3
	45	1043	897	7.8	7.1	6.5

MAS221T

Tc °C	Ta °C	P watt	P Kcal/h	V100 m ³	V80 m ³	V60 m ³
	20	3155	2748	37	34	31
	25	3067	2638	35	32	29
10	30	2927	2526	33	30	27
	35	2804	2411	31	29	26
	40	2669	2295	29	26	24
	45	2531	2177	27	25	22
	20	2924	2515	33	30	27
	25	2801	2409	31	28	25
5	30	2675	2300	29	26	24
	35	2548	2181	27	25	22
	40	2418	2079	25	23	21
	45	2285	1965	23	21	19
	20	2653	2282	28	25	22
	25	2524	2179	27	25	22
0	30	2414	2076	25	23	21
	35	2281	1970	23	21	19
	40	2166	1863	21	19	17
	45	2039	1754	19	17	16
	20	2381	2048	24	22	20
	25	2268	1950	23	21	19
-3	30	2152	1851	21	19	17
	35	2035	1750	19	17	16
	40	1915	1647	17	15	14
	45	1793	1542	17	15	14

MAS221N

Tc °C	Ta °C	P watt	P Kcal/h	V100 m ³	V80 m ³	V60 m ³
	20	2841	2443	31	28	26
	25	2725	2341	30	27	25
10	30	2604	2239	28	25	23
	35	2479	2132	26	24	22
	40	2349	2020	24	22	20
	45	2214	1904	22	20	18
	20	2580	2218	27	25	22
	25	2473	2127	26	24	22
5	30	2363	2032	24	22	20
	35	2249	1934	22	20	18
	40	2130	1832	21	19	17
	45	2006	1725	19	17	16
	20	2318	1993	23	21	19
	25	2222	1911	22	20	18
0	30	2122	1825	20	18	17
	35	2018	1735	19	17	16
	40	1910	1643	17	15	14
	45	1798	1546	17	15	14
	20	2057	1769	19	17	16
	25	1970	1694	18	16	15
-5	30	1881	1618	16	16	15
	35	1788	1538	17	15	14
	40	1691	1454	16	15	13
	45	1591	1368	14	13	12

Refrigeration Systems

Specification Reference Guide

WINE BLOCK MODELS	SLIDE IN SYSTEM			
	RCV101	RCV102	RCV201	RCV202
Part Number	3835040	3835055	3835060	3835065
Refrigeration Power	600W	1000W	1400W	2000W
Recommended Room Capacity	60m ³	60m ³	120m ³	100m ³
Temp. Range (°C)**	+10 to +20°C	+10 to +20°C	+10 to +20°C	+10 to +20°C
Max Ambient Temp. (°C)	40°C	40°C	40°C	40°C
Run/Full Load (Amps)	5.6/6A	8.2/8.9A	11.9/13A	14.1/16.9A
Ext. Dimensions	See pg 99	See pg 99	See pg 99	See pg 99
Temp. Display	Digital	Digital	Digital	Digital
Gross Weight (kg)	49g	52kg	77kg	79kg
Refrigerant	R404a	R404a	R404a	R404a
Plug Supplied	1	1	1	1
Power Supply	15A	15A	25A	25A
Features				
Defrost Type	R134a	R134a	Hot Gas	Hot Gas
Type of Control	Digital	Digital	Digital	Digital
Pre-wired For Internal Light	✓	✓	✓	✓
Pre-wired For Heated Door Trim	✓	✓	✓	✓
No Drainage Required*				
Warranty				
Parts (Years)	1	1	1	1

POWER DATA

RCV101					RCV102					RCV201					RCV202				
Tc °C	Ta °C	P watt	P Kcal/h	V60 m ³	Tc °C	Ta °C	P watt	P Kcal/h	V60 m ³	Tc °C	Ta °C	P watt	P Kcal/h	V60 m ³	Tc °C	Ta °C	P watt	P Kcal/h	V60 m ³
20	25	568	851	33	20	25	1469	1263	54	20	25	2130	1832	67	20	25	3094	2626	117
25	30	526	798	30	25	30	1378	1185	50	25	30	2008	1738	61	25	30	2950	2485	108
30	35	485	742	28	30	35	1278	1099	46	30	35	1878	1615	54	30	35	2688	2305	117
35	40	447	685	25	35	40	1172	1009	42	35	40	1740	1498	57	35	40	2459	2115	104
40	45	412	627	22	40	45	1085	917	38	40	45	1603	1379	51	40	45	2236	1923	90
45	50	379	569	19	45	50	1000	846	34	45	50	1463	1262	47	45	50	2056	1783	82
50	55	348	511	16	50	55	919	778	30	50	55	1328	1148	43	50	55	1866	1604	74
55	60	319	453	13	55	60	840	708	27	55	60	1200	1038	39	55	60	1701	1445	67
60	65	292	395	10	60	65	769	646	24	60	65	1080	932	35	60	65	1551	1305	61
65	70	267	337	7	65	70	704	592	21	65	70	980	840	31	65	70	1411	1185	54
70	75	244	279	4	70	75	644	543	18	70	75	890	761	27	70	75	1281	1084	48
75	80	222	221	1	75	80	588	498	15	75	80	800	678	23	75	80	1161	994	42
80	85	201	163	0	80	85	536	456	12	80	85	720	618	19	80	85	1051	904	36

Refrigeration Systems

Specification Reference Guide

WINE BLOCK MODELS	SPLIT SYSTEM							
	RDV101C	RDV101W	RDV102C	RDV102W	RDV201C	RDV201W	RDV202C	RDV202W
Part Number	3835010	3835404	3835023	3835407	3835027	3835028	3835406	3835403
Refrigeration Power	600W	1000W	1400W	2000W	600W	1000W	1400W	2000W
Recommended Room Capacity	40m ³	45m ³	45m ³	50m ³	80m ³	100m ³	80m ³	100m ³
Temp. Range (°C)**	+10 to +20°C	+10 to +20°C	+10 to +20°C	+10 to +20°C	+10 to +20°C	+10 to +20°C	+10 to +20°C	+10 to +20°C
Max Ambient Temp. (°C)	40°C	40°C	40°C	40°C	40°C	40°C	40°C	40°C
Run/Full Load (Amps)	7.3/8A	7.3/8A	8.9/9.6A	8.9/9.6A	12.4/13.5A	12.4/13.5A	13.8/15.3A	13.8/15.3A
Ext. Dimensions	See pg 100	See pg 100	See pg 100	See pg 100	See pg 100	See pg 100	See pg 100	See pg 100
Temp. Display	Digital	Digital	Digital	Digital	Digital	Digital	Digital	Digital
Gross Weight (kg)	46kg	46kg	49kg	49kg	80kg	80kg	82kg	82kg
Refrigerant	R404a	R404a	R404a	R404a	R404a	R404a	R404a	R404a
Plug Supplied	0	0	0	0	0	0	0	0
Power Supply	10A	10A	10A	10A	15A	15A	20A	20A
Features								
Defrost Type	Hot Gas	Hot Gas	Hot Gas	Hot Gas	Hot Gas	Hot Gas	Hot Gas	Hot Gas
Type of Control	Digital	Digital	Digital	Digital	Digital	Digital	Digital	Digital
Pre-wired For Internal Light	✓	✓	✓	✓	✓	✓	✓	✓
Pre-wired For Heated Door Trim	✓	✓	✓	✓	✓	✓	✓	✓
No Drainage Required*								
Warranty								
Parts (Years)	1	1	1	1	1	1	1	1

POWER DATA

RDV101C					RDV101W					RDV102C					RDV102W				
Tc °C	Ta °C	P watt	P kcal/h	V60 m ³	Tc °C	Ta °C	P watt	P kcal/h	V60 m ³	Tc °C	Ta °C	P watt	P kcal/h	V60 m ³	Tc °C	Ta °C	P watt	P kcal/h	V60 m ³
20	30	488	856	32	20	30	988	850	35	20	30	1469	1263	34	20	30	1469	1263	34
25	35	528	798	30	25	35	528	798	30	25	35	1378	1185	30	25	35	1378	1185	30
30	40	652	748	28	30	40	962	748	28	30	40	1179	1094	28	30	40	1179	1094	28
35	45	797	685	25	35	45	797	685	25	35	45	1173	1009	24	35	45	1173	1009	24
40	50	729	627	22	40	50	339	627	22	40	50	1066	917	20	40	50	1066	917	20
45	55	635	718	27	45	55	635	718	27	45	55	1278	1098	24	45	55	1278	1098	24
50	60	779	678	24	50	60	779	678	24	50	60	1171	1008	21	50	60	1171	1008	21
55	65	728	624	22	55	65	728	624	22	55	65	1091	936	17	55	65	1091	936	17
60	70	672	678	20	60	70	672	678	20	60	70	1019	876	16	60	70	1019	876	16
65	75	616	630	18	65	75	616	630	18	65	75	940	808	14	65	75	940	808	14
70	80	706	607	16	70	80	706	607	16	70	80	1094	845	13	70	80	1094	845	13
75	85	647	586	15	75	85	647	586	15	75	85	898	839	12	75	85	898	839	12
80	90	598	514	17	80	90	598	514	17	80	90	828	796	10	80	90	828	796	10
85	95	555	477	16	85	95	555	477	16	85	95	864	742	9	85	95	864	742	9
90	100	513	443	14	90	100	513	443	14	90	100	798	686	8	90	100	798	686	8

RDV201C					RDV201W					RDV202C					RDV202W				
Tc °C	Ta °C	P watt	P kcal/h	V60 m ³	Tc °C	Ta °C	P watt	P kcal/h	V60 m ³	Tc °C	Ta °C	P watt	P kcal/h	V60 m ³	Tc °C	Ta °C	P watt	P kcal/h	V60 m ³
20	30	2130	1852	87	20	30	2130	1852	87	20	30	3034	2628	137	20	30	3034	2628	137
25	35	2609	1720	81	25	35	2609	1720	81	25	35	2891	2483	128	25	35	2891	2483	128
30	40	3878	1615	74	30	40	3878	1615	74	30	40	2685	2303	117	30	40	2685	2303	117
35	45	4742	1498	67	35	45	4742	1498	67	35	45	2459	2115	104	35	45	2459	2115	104
40	50	5609	1379	61	40	50	5609	1379	61	40	50	2236	1923	92	40	50	2236	1923	92
45	55	3883	1632	73	45	55	3883	1632	73	45	55	2896	2319	113	45	55	2896	2319	113
50	60	4720	1479	66	50	60	4720	1479	66	50	60	2460	2116	104	50	60	2460	2116	104
55	65	3803	1373	61	55	65	3803	1373	61	55	65	2287	1967	93	55	65	2287	1967	93
60	70	5499	1286	56	60	70	5499	1286	56	60	70	2139	1840	87	60	70	2139	1840	87
65	75	3389	1139	51	65	75	3389	1139	51	65	75	1982	1705	79	65	75	1982	1705	79
70	80	3883	1061	50	70	80	3883	1061	50	70	80	2317	1993	97	70	80	2317	1993	97
75	85	3439	1251	54	75	85	3439	1251	54	75	85	2184	1818	86	75	85	2184	1818	86
80	90	2356	1456	49	80	90	2356	1456	49	80	90	1888	1664	78	80	90	1888	1664	78
85	95	1869	1091	43	85	95	1869	1091	43	85	95	1622	1367	71	85	95	1622	1367	71
90	100	1180	1015	41	90	100	1180	1015	41	90	100	1680	1443	64	90	100	1680	1443	64

Integrated lock keeps medicines secure

Audible safety alarm sounds should the temperature of the unit fall or rise outside the set Min/Max recording

Fan assisted cooling to regulate temperature throughout the cabinet

BMS dry contact point provided

Fan protection cover prevents product from being damaged

LED Light maximises product visibility

Evaporator protection cover prevents product from being damaged

Double glazed safety glass increases energy efficiency

Door open alarm

Rollers for easy placement

PVC-coated elevated bottom shelf for consistent temperature airflow

Adjustable legs for levelling



BROMIC
MediFridge

Bromic's Pharmacy Guild approved MediFridge range provides a safe and reliable storage solution for sensitive stock such as vaccines, probiotics, vitamins and other sensitive products.

109. MediFridge Medical Refrigerator

MediFridge medical refrigerators are designed to provide a safe storage solution for your sensitive stock.

Double-glazed glass panels provide a complete view of the cabinet interior and its contents so that you could easily locate an item before opening the fridge.

The integrated temperature alarm system ensures sensitive stock is maintained at the temperature and managed according to its storage requirements.



110. Specification Reference Guide

Medical Refrigeration



Complies to QCPP Standards

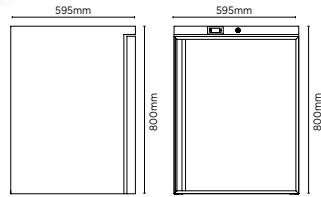

Complies to QCPP Standards

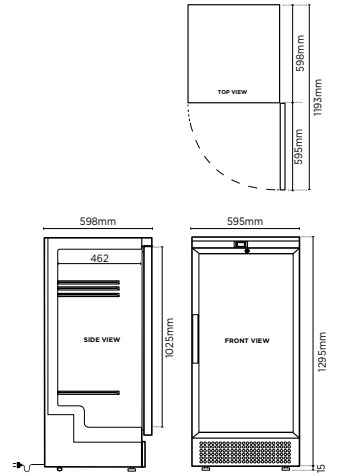

MED0140GD-NR



MediFridge™ 145L Vaccine Display Fridge

Part No.	Capacity	Weight
3736257	145L	40kg
	External (mm)	Internal (mm)
Width	595	491
Depth	595	510
Height	820	687

- Self-closing door
- Min/max temperature recording
- Factory installed lock with audible & visual alarm
- Adjustable PVC-coated airflow shelving
- Digital thermostat
- Temperature range: +2 to +8°C

MED0220GD



MediFridge™ 220L Upright Vaccine Display Fridge

Part No.	Capacity	Weight
3736217	215L	65kg
	External (mm)	Internal (mm)
Width	595	505
Depth	598	462
Height	1310	1025

- Self-closing door
- Min/max temperature recording
- Factory installed lock with audible & visual alarm
- Adjustable PVC-coated airflow shelving
- Digital thermostat
- Temperature range: +2 to +8°C



Complies to QCPP Standards

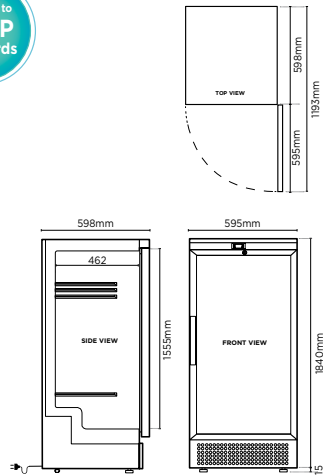

MED0374GD



MediFridge™ 372L Upright Vaccine Display Fridge

Part No.	Capacity	Weight
3736218	372L	81kg
	External (mm)	Internal (mm)
Width	595	505
Depth	598	462
Height	1840	1555

- Self-closing door
- Min/max temperature recording
- Factory installed lock with audible & visual alarm
- Adjustable PVC-coated airflow shelving
- Digital thermostat
- Temperature range: +2 to +8°C



350700051

Medi-Log II Digital Data Logger

- Meets Strive-for-Five guidelines and Department of Health recording interval requirements
- Simple one button operation to control all screens and functions
- Audible and on-screen alarms. Alarm set-points are preset to low 2°C and high 8°C (can be changed, if required)
- Time interval between readings 1 minute to 99 minutes
- 16,000 readings memory
- Free software to download and analyse all recorded data on your Windows computer (via USB cable)
- Includes Glycol Vial, 2 Meter External probe and USB Cable

Medical Refrigeration

Specification Reference Guide

Model	MED0140GD-NR	MED0220GD	MED0374GD
Part Number	3736257	3736217	3736218
Ext. Width (mm)*	595	595	595
Ext. Depth (mm)*	595 (635 inc handle)	598	598
Ext. Height (mm)*	820	1310	1840
Capacity	145L	215L	372L
Temp. Range	+2 to 8°C	+2 to 8°C	+2 to 8°C
Plug Supplied	✓	✓	✓
Power Supply	10A	10A	10A
Features			
Internal Light	✓	✓	✓
Door Shape	Flat Glass	Flat Glass	Flat Glass
Feet Included	30mm feet at front. rollers at back	30mm feet at front. rollers at back	30mm feet at front. rollers at back
No. of Shelves inc. Base	4	4	6
Default Door Hinge	Right	Right	Right
Warranty			
Parts	5	5	5
Labour	5	5	5

*Dimensions exclude any protrusions

BROMIC SMART-HEAT™

Divided into our distinct Platinum and Tungsten ranges, all Bromic outdoor heaters are designed and engineered in-house and are constructed from premium materials to create products that strike the perfect balance between performance, reliability and beauty.



PLATINUM SMART-HEAT™ ELECTRIC

Our Platinum Smart-Heat™ Electric heater is specifically suited for low-clearance and design-focused spaces in mind.

These units are constructed from premium materials and able to heat areas as large as 10m.

Available in Black or White finish.
Mount options: Recessed, Wall or Ceiling.

Black

- 2300W (Part No. 2620240)
- 3400W (Part No. 2620245)

White

- 2300W (Part No. 2620247)
- 3400W (Part No. 2620248)



PLATINUM SMART-HEAT™ GAS

The Platinum Smart-Heat™ Gas combines elegant aesthetics with industry-leading performance to offer value and reliability to premium venues and homes.

Available in two different sizes across both LPG and Natural Gas configurations, these units are able to directionally project a comfortably diffused radiant heat across areas as large as 20m².

Mount options: Recessed, Wall or Ceiling.

- 300-Series LPG (Part No. 2620130-1)
- 300-Series Natural Gas (Part No. 2620131-1)
- 500-Series LPG (Part No. 2620140-1)
- 500-series Natural Gas (Part No. 2620141-1)



DESIGN SERVICE

As part of our complementary service, Bromic Heating Specialists will custom design and tailor a solution to best heat your outdoor living and entertainment spaces.

Learn more at bromic.com/designservice



WIRELESS CONTROLLERS

With the option to connect groups of heaters from a single point as well as dimming heating outputs, the Smart-Heat™ range of controllers provide a simple, yet powerful solution to controlling your environment.

Learn more at bromic.com/gowireless



TUNGSTEN SMART-HEAT™ ELECTRIC

The Tungsten Smart-Heat™ Electric brings high-performance radiant heating to open outdoor applications and semi-enclosed spaces alike.

These units are available in four sizes and provide a wide wall of heat across a vast footprint, maximising the comfort created by each unit to heat areas as large as 15m².

Mount options: Recessed, Wall or Ceiling.

Black

- 2000W (Part No. 2620262)
- 3000W (Part No. 2620263)
- 4000W (Part No. 2620264)
- 6000W (Part No. 2620265)



TUNGSTEN SMART-HEAT™ GAS

Powered by highly-efficient gas-fired ceramic burners, the Tungsten Smart-Heat™ Gas utilizes an open mesh shield to prioritize performance.

Available in two different sizes across both LPG and Natural Gas configurations, these units provide powerful heating in areas as large as 20m².

Mount options: Recessed, Wall or Ceiling.

- 300-Series LPG (Part No. 2620330-1)
- 300-Series Natural Gas (Part No. 2620331-1)
- 500-Series LPG (Part No. 2620340-1)
- 500-Series Natural Gas (Part No. 2620341-1)



TUNGSTEN SMART-HEAT™ PORTABLE

It's neutral black finish, and award-winning design makes it a piece of modern art.

The Tungsten Smart-Heat™ Portable heater offers efficient directional heat and a versatile heating solution for the outdoor settings.

It's modular construction with built-in wheels allows for easily maneuverability throughout tighter spaces.

Heat Output: Coverage of up to 20m², the Tungsten Smart-Heat™ Portable delivers a widespread heat field of up to 4m wide & 5m deep.

- Portable: (Part No. 2620350)

BROMIC
HEATING

For more information on Bronic heaters visit bromic.com/heat or email enquiries@bromic.com

BROMIC PLUMBING & GAS

Bromic Plumbing & Gas has been a core facet of the Bromic Group's operations since inception, supporting the daily operations of plumbers and tradespeople with high-quality products for decades and growing to become trusted by trade across Australia, New Zealand, and the Pacific Islands.



SEALANTS & LUBRICANTS

Bromic Plumbing & Gas are a complete Sealants & Lubricants solutions provider with products from trusted international brands LA-CO & LOXEAL. Bromic provide the best suited sealant or lubricant for the job. Our range of products comply with all required approvals including the Australian Gas Association (AGA) and WaterMark compliance.



REGULATORS

Bromic Plumbing & Gas provide a wide variety of regulators to suit applications from recreational to professional, in both Natural Gas & LPG (propane). Our range of regulators includes everything from single stage to dual stage regulators with both manual & automatic changeover options available.



SOLDERING & BRAZING

Bromic is the leading Australasian supplier of gas-based soldering and brazing tools and accessories in the industrial, HVAC, plumbing and hardware markets. Product design and quality are specifically engineered for trade environments so that trade consumers can rely on the Bromic, Bernzomatic, Sievert and LA-CO brands to get their job done.



HEATING SOLUTIONS

Our heating products cover commercial, industrial, outdoor & indoor applications. Our Stratos Brahma series offers a stylish wall mounted flued indoor heating solution, and our Supaheat II range offers portable flueless indoor heating. Our Heat-Flo™ range includes Tile heaters for outdoor heating and LPG blow heaters that deliver instant, economical heat for industrial or commercial applications.



PUMP SOLUTIONS

The Bromic Waterboy™ range of pumps offers a complete solution for the transfer of water. Our diverse range includes both submerged and external pump solutions in versatile configurations to fulfil the needs of all rainwater harvesting systems.



VALVES

Bromic Plumbing & Gas offer a variety of valves available in a number of handle types and thread configurations. Our valves offer reliability and affordability in both gas and water applications and come with AGA or WaterMark approval depending on the valve application.



HOSE CONNECTIONS

Bromic gas and water hoses are available in a vast variety of lengths, materials and connection types. Our hoses offer reliability and affordability, with all Bromic gas hoses having the Australian Gas Association (AGA) approval. Bromic gas and water hoses are available in standard lengths ranging from 200mm to 3000mm with non-standard lengths available as a custom order.



TEST EQUIPMENT

Bromic Plumbing & Gas offer a complete range of professional test equipment suited for plumbing, HVAC and pressure testing applications. Trusted by Trade™ our equipment is designed to make the job easier, helping to save on both money and time.



COOKING & OUTDOORS

Bromic Plumbing & Gas's outdoor products and accessories are designed to meet the challenges of caravan and marine applications. Our outdoor cookers withstand the rigours of outdoor activities and can easily be fitted with a number of available hoses and adaptors specific to the leisure industry.

BROMIC
PLUMBING & GAS

For more information on Bromic plumbing visit bromicplumbing.com or email plumbing@bromic.com

Terms & Conditions

Trading Terms & Warranty Details

All Bromic products are manufactured to the highest quality standard and are supported by our Extra Care Service Warranty, including guarantees against any material or workmanship defects; guarantees that cannot be excluded under Australian Consumer Law. To ensure you are up to date with all Terms & Conditions associated with the purchase of a Bromic unit, please visit www.bromicgroup.com/warranty-information

IMAGES, SPECIFICATIONS

Due to the nature of the printing process, colours shown in this catalogue may differ from the actual colour of products. All images, drawings, graphics and design elements contained in this catalogue are subject to Australian and International copyright law. No part of this catalogue may be reproduced, copied or stored in part or whole without the prior written permission of Bromic Pty Ltd. Bromic reserves the right to change specifications and any other information contained in this catalogue with no recourse from customers.

ORDERING

Orders can be placed by phone, fax, online or email. Our catalogue includes Part Numbers and Model codes to ensure ease of use, with the customer in mind.

SPECIAL ORDER Special orders: 16 - 20 weeks delivery

DIMENSIONS

Unless otherwise indicated, all dimensions are external and given in millimetres.

COMPLIANCE

Products stocked by Bromic comply with all relevant regulatory requirements i.e. GEMS, AGA, electrical and safety requirements.

Contact Your Local Western Australian Representative Today!



**Scientific
Partners
Australia**

Your partner in science

Scientific Partners Australia

Mob: 0447 733 832

E: sales@scientificpartners.com.au

BROMIC
group



SYDNEY HEAD OFFICE & SHOWROOM

10 Phiney Place, Ingleburn (Sydney)
NSW 2565 Australia
T: AU 1300 276 642
F: (+61) 1300 735 115
E: refrigeration@bromic.com

BROMIC
HEATING

BROMIC
PLUMBING & GAS

BROMIC
REFRIGERATION

BROMICREFRIGERATION.COM.AU